

**K**indermann



**2011**

PRESENTATION TECHNOLOGY  
INSTALLATION SOLUTIONS

The innovative manufacturer and expert in "presentation", "installation" and "conferencing" has an excellent reputation for high quality and user-friendly solutions.

Its sales programme ranges from the single projector to the complete equipment of conference rooms and is one of the biggest of its branch in Europe.

Many of these products are made in Germany by Kindermann. To supplement the sales programme Kindermann distributes well-known brands, e.g. Epson, Sanyo, Sharp, Lumens, Projecta and many more.

Kindermann supports its dealers with competent technical advice and individual guidance for projects, including planning a system, supplying the technology and realizing the integration.



"Presentation" stands for various types of projectors and displays.



"Installation" comprises all components required for room installation as well as for digital signage.



"Conferencing" consists of sophisticated conference and media solutions, including MultiMedia furniture and video conference systems.

# TABLE OF CONTENTS

<b>Projectors, visualizers</b>	
Data/video projectors Kindermann	04 - 08
Data/video projectors Epson, Sanyo, Mitsubishi, Optoma	09
Accessories for data/video projectors	10
Kindermann overhead projectors	11 - 15
Visualizers	16 - 18

<b>Displays</b>	
LCD displays - Conrac, Sanyo, Mitsubishi, Sharp	19
Focustouch - interactive touch screen displays	20 - 21
Dynamic - monitor solutions	22

<b>Interactive systems</b>	
Interactive ēno whiteboards Polyvision	23

<b>Digital signage</b>	
easescreen - content management software	24 - 25
Esign - room booking software	26
EVA - your virtual receptionist	27
DoorSigns - room booking systems	28 - 29
Information terminals, designer displays	30 - 32

<b>Video conferencing</b>	
Video conference systems	33

<b>MultiMedia furniture</b>	
MultiMedia furniture	34 - 35
MultiMedia desks and trolleys	36 - 39

<b>Presentation systems</b>	
Presentation furniture and trolleys	40 - 44
Projection boards, whiteboards, pin boards, flipcharts	45 - 47
Accessories	48 - 49
VisuLine rail system	50 - 51
Copyboards	52
H3O Kindermann lecterns	53

<b>Mounting systems</b>	
Projector mounts	54 - 61
Anti-theft protection	62 - 63
Accessories for projector mounts	64
Projection modules	65
Ceiling lifts	66 - 69
Ceiling mirrors	70 - 71
Accessories for ceiling lifts and ceiling mirrors	72 - 73
MaxxMount system	74 - 77
Stands for interactive whiteboards	78
H3O Kindermann display stands	79
Display mounts and stands	80 - 83

<b>Signal management</b>	
Multimedia connection systems	84 - 102
• Adapter plates and mounting material for modular systems	85 - 91
• Solutions for floor boxes	92
• CablePort Standard	93 - 95
• CablePort Flex and adapter plates	96 - 100
• Evoline desktop connections	101 - 102
Floor channels	103
Installation cables 13/19-pin	104 - 106
MediaRoller 30	106
Cables, gender changers, adapters, av cables	107 - 113
QuickSelect presentation interface	114 - 115
Signal amplifiers, splitters, switchers	116 - 119
DVI switchers, HDMI switchers, accessories	119
19" telescope rack system, accessories	120

<b>Media control</b>	
PIXIE media control	121 - 124
ProTouch media controls	125 - 127

<b>Audio systems</b>	
Mobile audio systems, accessories	128 - 130
Active loudspeakers, mixers, amplifiers	131 - 132
Microphones	133

<b>Projection screens</b>	
Guideline for large screen projection	134 - 135
Easy install	136
Electrical screens	137 - 141
Manually operated wall screens, accessories	142 - 144
Tripod screens, mobile screens	145 - 146



## KINDERMANN KX 400C

The new generation of short throw projectors

- Ideal for interactive whiteboards or short projection distances
- Produces an image of a 205 cm diagonal at a projection distance of 1 m
- Additional safety features: antitheft device and password
- 7 W loudspeaker
- Easy maintenance and control via network browser



### Shadow-free projection

Due to the ultra wide angle lens only a short distance between projector and screen is required and the lecturer does not cast a shadow on the image.

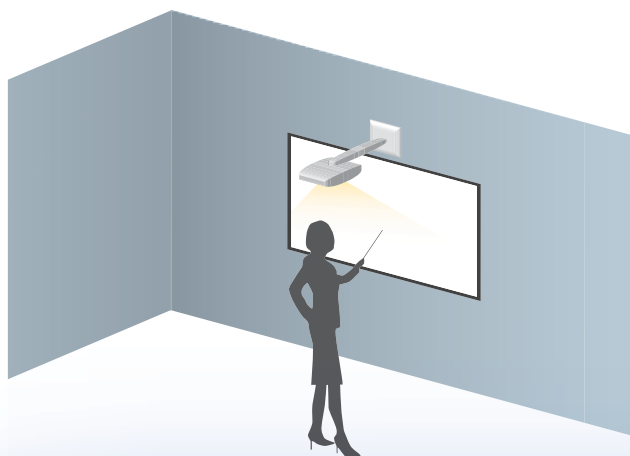

Kindermann	KX 400C
Ref. No.	3000 000 400
Display type	LCD
Resolution	XGA
Lumens (ANSI)	2600
Weight	3.8 kg







## KINDERMANN KX 5050 / 5050 NL / 5050 W

Reliable projectors for permanent installation



- High connectivity: 5 video in, 4 audio in, 1 audio out (synchronized with the image)
- Highly efficient filter system (optional against dust and smoke)
- Side access for lamp and filter change
- Low fan noise (29 dBA in eco mode)
- Quick power on/off

### Safety features:

- Password protection and safety rod
- LAN for system check and network control with web browser
- KX 5050 W with 16 : 10 format
- Optional interchangeable lenses available for KX 5050 NL



Kindermann	KX 5050	KX 5050 NL	KX 5050 W
Ref. No.	3000 000 023	3000 000 027	3000 000 293
Display type	LCD	LCD	LCD
Resolution	XGA	XGA	WXGA
Lumens (ANSI)	5200	5200	4600
Weight	8.2 kg	7.2 kg (without lens)	8.2 kg

Easy change of lamp and air filter



High connectivity



# VIRTUOSO PRESENTATIONS

## KINDERMANN KX 3200 SERIES

Powerful 3LCD business projectors



- KX 3250 W with 16:10 format - perfect for DVI presentations with a laptop
- Quick power on/off (in only 10 seconds)
- Low fan noise - 29 dB in eco mode
- Digital and analogue inputs, high connectivity  
DVI-I, LAN (KX 3250 W, KX 3300), RS232 etc.
- Integrated 8 W loudspeaker
- **Handy IR remote control**  
with mouse (except KX 3200 active) and laser pointer
- **Safety**  
Kensington lock, anti-theft device,  
PIN code query (can be switched off)
- **Many automatic functions**  
Source selection, synchronization,  
ceiling projection, vertical Keystone correction
- **Maintenance-friendly**  
Easy change of lamp and filter (sideways),  
even if mounted on the ceiling



Kindermann	KX 3200	KX 3200 wide	KX 3300	KX 3250 W
Ref. No.	8496 000 000	8475 000 000	8498 000 000	8497 000 000
Display type	LCD	LCD	LCD	LCD
Resolution	XGA	XGA	XGA	WXGA
Lumens (ANSI)	2600	3000	3500	2600
Weight	3.3 kg	3.6 kg	3.3 kg	3.3 kg



# KINDERMANN KX 3200 ACTIVE

Interactive presentation without special board



- Whiteboard function due to integrated camera which communicates with the two IR pointers
- Control software on CD ROM, ready in no time, no installation necessary
- **Good for nearly any projection surface**  
Operation control in real time, processing, changing, printing and mailing of data, etc.
- For stationary and mobile use, interactive function for images sized 1.5 – 3 m

**The advantages:**

- With the help of the IR pointer or pen you can control all functions of your software directly, on any projection surface.
- How to operate the interactive unit can be learned in a few minutes.
- Contents can be marked, altered or stored with the IR pointer or pen.

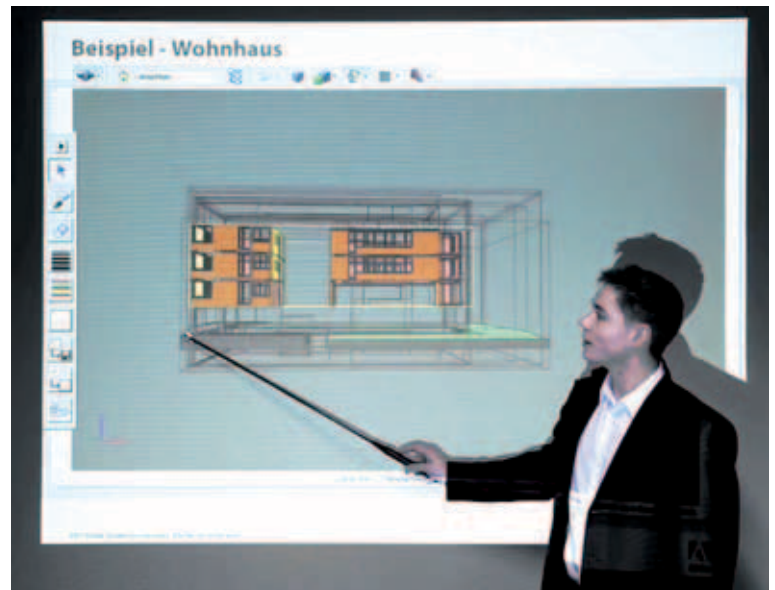

Kindermann	KX 3200 active
Ref. No.	8499 000 000
Display type	LCD
Resolution	XGA
Lumens (ANSI)	2600
Weight	3.4 kg



System requirements	Windows	MAC
System software	MS Windows®, 2000 (SP4), XP (SP 2) or higher; VISTA, Windows® 7 (32 bit)	MAC OS X 10.4, 10.5 or higher
Processor	similar to Intel Pentium IV or higher	Intel or power PC
Memory (RAM)	min. 512 MB	min. 512 MB
Hard disk storage	min. 30 MB	min. 10 MB
Min. computer requirements	CD-ROM drive, 1 x USB 2.0 port	CD-ROM, 1 x USB 2.0
Image diagonal (interactive function)	1.5 – 3 m	1.5 – 3 m
Supplied with	IR telescope pointer and IR pen, software light pen for interactive presentations	



## Technical data

Model	Kindermann KX 400C	Kindermann KX 5050 / KX 5050 NL* / KX 5050 W	Kindermann KX 3200 KX 3300 / KX 3200 wide	Kindermann KX 3250 W / KX 3200 active
Ref. No.	3000 000 400	3000 000 023 / 3000 000 027 3000 000 293	8496 000 000 / 8498 000 000 8475 000 000	8497 000 000 / 8499 000 000
Native resolution (pixels)	XGA	XGA / XGA / WXGA	XGA	WXGA / XGA
Supported resolutions	VGA - UXGA	VGA - UXGA	VGA - UXGA	VGA - UXGA
Lumens	2600	5200 / 5200 / 4600	2600 / 3500 / 3000	2600
Display type	LCD	LCD	LCD	LCD
Contrast ratio	800 : 1	500 : 1	500 : 1	500 : 1
Frequency: horizontal, vertical	15-100 kHz, 50-100 Hz	15-107 kHz, 50-120 Hz	31-92 kHz, 48-120 Hz	31-92 kHz, 48-120 Hz
Focal length in mm	9.02	24.0 - 28.8 / * depending on lens	18.5 - 22.2	18.5 - 22.2
Image diagonal in m	1.02 - 5	1 - 7.62 / * depending on lens	1.02 - 7.68 / 1.02 - 7.68 / 0.5 - 7.68	1.02 - 7.68
Projection distance in m	0.51 - 2.56	1.17 - 14 / * depending on lens	1.0 - 10.6 / 1.0 - 10.6 / 0.5 - 7.4	1.0 - 11.25 / 1.0 - 10.6
Ratio (distance : image width)	0.6 : 1	1.47 - 1.78 : 1 / * depending on lens	1.47 - 1.78 : 1 / 1.47 - 1.78 : 1 / 1.0 - 1.2 : 1 with wide angle adapter	1.54 - 1.85 : 1 / 1.47 - 1.78 : 1
Interchangeable lenses	no	no / * yes (3 x)	-	-
Lamp	230 W NSH	330 W UHP	200 W UHP / 230 W UHP / 220 W UHP	200 W UHP
Noise level	29 dB (Eco)	30 dB (Eco)	28 dB / 29 dB (Eco) / 28 dB (Eco)	28 dB (Eco)
Dimensions in mm	345 x 94 x 306	480 x 152 x 360	325 x 97 x 260	325 x 97 x 260
Weight in kg	3.8	8.2 / 7.2* (without lens)	3.3 / 3.3 / 3.6	3.3 / 3.4
<b>Inputs / outputs</b>				
Computer VGA (analogue)	1 x HD 15, 1 x HD 15 switchable IN/OUT	1 x HD 15	1 x HD 15	1 x HD 15
DVI/HDMI (digital)	-	1 x DVI-I	1 x DVI-I	1 x DVI-I
Video	1 x Cinch (component Y)	1 x Cinch	1 x Cinch	1 x Cinch
S-Video	1 x Mini DIN 4 Pin	1 x Mini DIN 4 Pin	1 x Mini DIN 4 Pin	1 x Mini DIN 4 Pin
Component video	1 x Cinch/3	1 x Cinch/3	1 x Cinch/3	1 x Cinch/3
RS 232 interface	1 x RS 232 (9 pin)	1 x RS 232 (9 pin)	1 x RS 232 (9 pin)	1 x RS 232 (9 pin)
LAN control	1 x LAN (RJ45)	1 x LAN (RJ45)	- / 1 x LAN (RJ45) / -	1 x LAN (RJ45) / -
Mouse interface	-	1 x USB/B	1 x USB/B	1 x USB (B) / 1 x USB (B) for active control
Audio (computer)	1 x 3.5 mm stereo jack	2 x 3.5 mm stereo jack	2 x 3.5 mm stereo jack	2 x 3.5 mm stereo jack
Audio (video)	1 x Cinch/2	2 x Cinch/2	1 x Cinch/2	1 x Cinch/2
Monitor output	yes (switchable IN/OUT)	yes	yes	yes
Audio output	yes	yes	yes	yes
<b>Special functions</b>				
Keystone correction (digital)	vertical ± 30°	vertical ± 30°	vertical ± 30°	vertical ± 30°
Loudspeaker	1 x 7 W	1 x 8 W	1 x 8 W	1 x 8 W
Safety features	Kensington lock, password protection	Kensington lock, password protection	Kensington lock, password protection	Kensington lock, password protection
Laser pointer in remote control	no	yes	yes	yes
Voltage	100-240 V AC, 50/60 Hz	100-240 V AC, 50/60 Hz	100-240 V AC, 50/60Hz	100-240 V AC, 50/60 Hz
Special features	Lamp change on top, user logo	Quick power on/off, lamp and filter change sidewards, user logo	Quick on/off (10 s), lamp and filter change sidewards, user logo	Quick on/off (10 s), lamp and filter change side- wards, user logo <b>KX 3200 active:</b> Interactive projector
Lamp warranty	1 year or 500 h (whatever comes first)	1 year or 500 h (whatever comes first)	1 year or 500 h (whatever comes first)	1 year or 500 h (whatever comes first)
Warranty	2 years bring-in	2 years bring-in	2 years bring-in	2 years bring-in
Options	-	3 interchangeable lenses (KX 5050 NL only)	- / - / Wide angle adapter de- tachable, ratio then 1.47 - 1.78:1	-
Package includes	IR remote control, set of cables	IR remote control with mouse and laser pointer, set of cables	IR remote control with mouse and laser pointer, set of cables, soft bag	IR remote control with mouse and laser pointer, set of cables, soft bag <b>KX 3200 active:</b> IR telescope pointer and IR pen





Kindermann is a distributor of several well-known brands and thus can offer data/video projectors for any application:

- meetings and small conferences
- mobile presentations
- large conferences and seminars
- showrooms and exhibitions
- educational and home use

For further information about the latest models please visit our website [www.kindermann.com](http://www.kindermann.com) resp. the original websites of the manufacturers:  
[www.epson.com](http://www.epson.com)      [www.sanyo-lcdp.com](http://www.sanyo-lcdp.com)      [www.optoma.com](http://www.optoma.com)      [www.mitsubishi-presentations.com](http://www.mitsubishi-presentations.com)

**EPSON**<sup>®</sup>  
 EXCEED YOUR VISION

**Optoma**

**SANYO**  
 Think GAIA For Life and the Earth

**MITSUBISHI  
 ELECTRIC**  
*Changes for the Better*



## INTERCHANGEABLE LENSES

Insertion by authorized Kindermann partners

Lenses for Kindermann projector KX 5050 NL

Model	Focal length	Distance	Diagonal	KX 5050 NL	Ref. No.
ELS01	f= 28.8 - 36.6 mm	2 - 20 m	1.5 - 12.0 m	Ratio 1.8 - 2.3:1	8708 000 000
ELS02	f= 36.5 - 45.8 mm	3 - 25 m	1.5 - 12.0 m	Ratio 2.3 - 2.9:1	8708 000 001
ELS03	f= 51.0 - 64.3 mm	3 - 30 m	1.5 - 12.0 m	Ratio 3.1 - 4.1:1	8708 000 002

How to calculate the proper image size / width

image size

Projection ratio R	=	distance : image width
Distance	=	image width x projection ratio
Image width	=	distance : projection ratio

image width

4:3 format,	XGA (1024 x 768), SXGA (1400 x 1050), UXGA ( 1600 x 1200)	diagonal :1.25
16:9 format,	Full-HD (1920 x 1080), 720p (1280 x 720)	diagonal :1.15
16:10 format,	WXGA (1280 x 800), WUXGA (1920 x 1200)	diagonal :1.18

Due to manufacturing tolerances deviations of ± 10 % are possible!

## AIR VIDEO 2000

Universal W-LAN adapter for data/video projectors

- Supports projectors with SVGA, XGA and WXGA resolution (1280 x 768 pixels)
- Installation by software download from W-LAN receiver or via USB dongle stick
- Audio output for sound transmission
- Transmits monitor images via W-LAN or LAN to a projector / panel with VGA input
- Conference master: a user registered as administrator controls the access of other participants
- Video play mode for MPEG 1, 2, 4 with 60 images / second



Kindermann Air Video 2000 8960 000 000

Kindermann Air Video 2000	
Interface	1 x LAN / RJ 45 W-LAN (802.11b/g wireless) 1 x audio out (3.5 mm jack) 1 x VGA output (HD 15)
Supported systems	Windows Vista (with AERO glass effect) Windows XP Home, Professional with SP2
Colour intensity	16 or 32 Bit
Function	Wireless presentation / video playback conference control
Safety	WEP 64 / 128 Bit / Encryption / login code
Resolution	SVGA (800 x 600) XGA (1024 x 768) WXGA (1280 x 768)
Video streaming	MPEG1 playback (MPG, MPEG, DAT) MPEG2 playback (MPG, MPEG, VOB) MPEG4 playback (ASF, WMV9, up to 1080p)
Power supply	100-240 VAC / 5 VDC
Weight	0.370 kg
Dimensions	140 x 106 x 34 mm
Package includes	Power supply, CD-ROM, manual, mounting plate

## KINDERMANN INTERACTIVE KIT

Makes any projector interactive



Kindermann interactive kit 3000 000 269

The interactive kit turns any projection surface (screen, whiteboard, wall etc.), in combination with a standard projector, into an interactive surface. You can control the presentation "on screen" or write with "virtual ink" directly on the projected image.

The interactive kit works with infrared pens and is suitable for data/video projectors with a ratio of > 1.2.

Kindermann interactive kit	
Package includes	<ul style="list-style-type: none"> <li>• Receiver, Mini USB cable 5P/A, 1.5m (extendable up to 25 m with optional USB extender Cat5 No. 8756 000 005)</li> <li>• IR telescope pointer and IR pen</li> <li>• 2 AA batteries</li> <li>• Bracket for fixing on a projector holder of a ceiling mount</li> <li>• Quick start manual</li> <li>• CD-ROM with user manual and interactive software "LightPen II for Windows"</li> </ul>
Technology	IR
Sensor accuracy	± 6 pixels
Screen size	max. 3 m

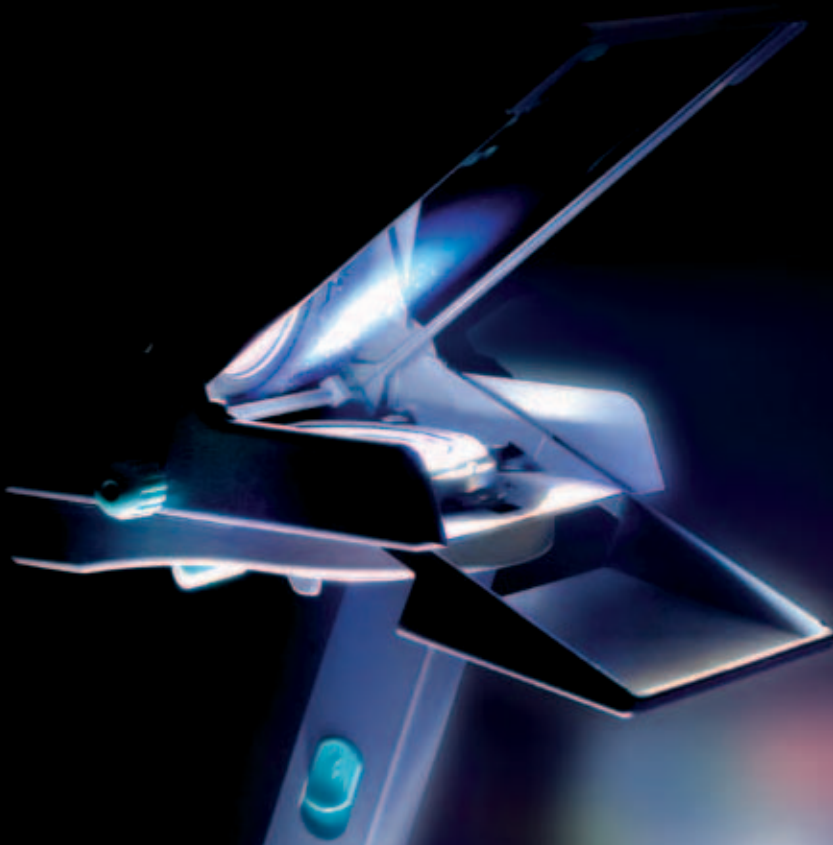

#### Famulus alpha

Low budget projectors

#### Famulus beta

Professional projectors for schools, seminars and training

#### Famulus reflex

Light-weight projector for mobile use

## OVERHEAD PROJECTORS

The classical presentation media

- High light output
- Low price
- Low maintenance costs
- Easy to operate
- Plug and play



#### High quality

KINDERMANN overhead projectors have always been developed and produced at our Ochsenfurt headquarters. They are subject to strict quality controls.

#### ISO certified

The high quality standard of the whole manufacturing process is guaranteed by the German industrial standard DIN ISO 9001:2000.

#### Environment-friendly

KINDERMANN overhead projectors are environment-friendly. All components of the bodies are marked with different codes for different materials. They are not glued together so that they can be easily dismantled and recycled.

#### Maintenance-friendly

All KINDERMANN overhead projectors are maintenance-friendly, their functions are easy to check and, if necessary, components can be exchanged quickly.

KINDERMANN provides an excellent aftersales service, even many years after the purchasing date.



# FAMULUS REFLEX T

Small, light and super bright – flexible in use

## The highlights

### Exclusive features

- Excellent light output: 3000 lumens
- In transport position only 11 cm high

### The advantages of the reflex technology

- Easy transport
- Ready for projection in no time
- Low weight
- Extremely flat working surface

### Features

- 3-element lens  $f = 300$  mm
- Quick lamp changer with 2 halogen lamps
- Working surface A4 horizontal and vertical
- Supplied with carrying case
- Glare-free fresnel lens

reflex T  
3000  
lumens



#### Space-saving

Can be completely folded



#### Carrying case

included

### Mobile overhead projector

<b>Famulus reflex T</b> 2 halogen lamps 24 V/250 W/50 h • 3000 lumens • 6.5 kg	6089 000 003
<b>Halogen lamp 24 V/250 W</b> 300 hours	6049 000 000
<b>Deluxe carrying case</b>	6159 000 001



# FAMULUS ALPHA 250 / ALPHA 400

## School projectors for the small budget – “Made in Germany”

You are looking for a solid, reliable and maintenance-free overhead projector with a good projection quality, but you have only a small budget? Then the Famulus alpha projectors are the proper choice for you.

**+** **Patented safety lens head**

- No overheating of the lens

**+** **Foldable projection arm**

- For space-saving storage

**+** **No disturbing fan noise**

- < 31 dB(A) only

alpha 250  
**2500**  
lumens

alpha 400  
**4400**  
lumens



### The highlights

#### Exclusive features

- Patented safety lens head with rotating knob for precise picture height adjustment
- Top quality “Made in Germany” by Kindermann

#### Standard features

- High-quality 3-element lens (315 mm) – high sharpness, good contrast
- Quick lamp changer with 2 halogen lamps
- Folding projection arm
- Very low fan noise - < 31 dB(A) only
- All operating buttons on top
- Glare-free fresnel lens
- Retractable pins for holding transparencies
- Optional roll attachment



**Safety lens head**  
No overheating of the lens



**Folding arm**  
For space-saving storage and easy transport

### Desktop overhead projectors

<b>Famulus alpha 250</b>	2 halogen lamps 24 V/250 W/50 h • 2500 lumens • 8.2 kg	<b>9052 000 016</b>
<b>Famulus alpha 400</b>	2 halogen lamps 36 V/400 W/50 h • 4400 lumens • 9.4 kg	<b>9053 000 016</b>
<b>Halogen lamp 24 V/250 W, 300 hours</b>		<b>6049 000 000</b>
<b>Halogen lamp 36 V/400 W, 300 hours</b>		<b>6071 000 000</b>
<b>Dustcover</b>		<b>6806 000 001</b>
<b>Roll attachment</b>		<b>9011 000 000</b>

### Picture size chart

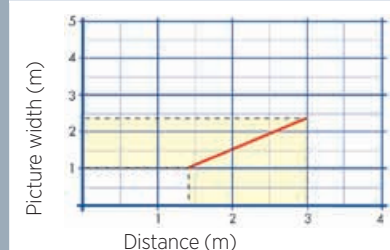

# FAMULUS BETA 250/BETA 400

Professional projectors for schools, seminars and training

The Famulus beta projectors are characterized by a user-friendly technology that makes them easy to operate.

- +** **Patented safety lens head**
  - No overheating of the lens
- +** **No disturbing fan noise**
  - < 30 db(A)
- +** **Lockable projector body**
  - Protects against manipulation

## The highlights

### Exclusive features

- Patented safety lens head with precise picture height adjustment
- Manual focal compensation for upward projection
- Lockable projector body
- Slot for anti-theft device
- Condensor lens for a perfect overall illumination of the image

### Standard features

- High-quality 3-element vario focal lens  $f = 275 - 320 \text{ mm}$  - no colour fringes
- Quick lamp changer with LED for lamp failure
- Economy switch
- Folding projection arm
- Extremely low fan noise - < 30 dB(A) only
- All operation buttons on top
- Glare-free fresnel lens
- Retractable pins for holding transparencies
- Optional roll attachment



**Anti-theft device**  
Slot to attach a lock



**Folding arm**  
For space-saving storage and easy transport



## Desktop overhead projectors

<b>Famulus beta 250</b>	2 halogen lamps 24 V/250 W/50 h • 3500 lumens • 9.5 kg	9000 000 000
<b>Famulus beta 400</b>	2 halogen lamps 36 V/400 W/50 h • 5400 lumens • 10.5 kg	9005 000 000
<b>Halogen lamp 24 V/250 W, 300 hours</b>		6049 000 000
<b>Halogen lamp 36 V/400 W, 300 hours</b>		6071 000 000
<b>Dust cover</b>		6806 000 001
<b>Roll attachment</b>		9011 000 000
<b>Anti-theft device</b>		5775 000 000

## Picture size chart

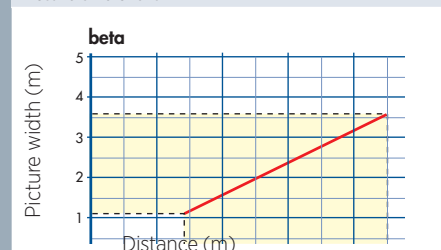

# WORKING MATERIAL

## Transparency rolls

For the professional preparation of a lecture and for making notes during the lecture. They are made from environmentally-friendly materials and suitable for felt pens.



Transparency roll	30 m long / 29.7 cm wide	6074 000 000
Transparency roll	15 m long / 36 cm wide	6866 000 001

## Anti-glare panel

Anti-glare device with joint and thread, to be attached to the projection head of transmissive type overhead projectors.



Anti-glare panel	6108 000 000
------------------	--------------

# OHP - DIMENSIONS AND TECHNICAL DATA

### Famulus alpha

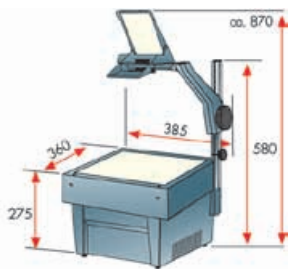

- In transport position:**
- 385 x 405 x 500 mm

### Famulus beta



- In transport position:**
- 385 x 320 x 525 mm

### Famulus reflex T



- In transport position:**
- 293 x 110 x 430 mm

OHP model	Transmissive projectors				Reflective projector
	alpha 250	alpha 400	beta 250	beta 400	reflex T
Ref.No .	9052 000 016	9053 000 016	9000 000 000	9005 000 000	6089 000 003
3-element lens in mm	315	315	275 - 320	275 - 320	300
Halogen lamp in Watt	250	400	250	400	250
Average lamp life in hours	50	50	50	50	50
Light output in lumens	2500	4400	3500	5400	3000
Working surface in mm	285 x 285	285 x 285	285 x 285	285 x 285	285 x 285
Focal compensation	-	-	•	•	•
LED for lamp change	-	-	•	•	-
Quick lamp changer	•	•	•	•	•
Economyswitch	-	-	•	•	-
Overheating device	•	•	•	•	•
Folding projection arm	•	•	•	•	•
Slot for anti-theft device	-	-	•	•	-
Lockable projector body	-	-	•	•	-
Voltage	230 V	230 V	230 V	230 V	230 V
Frequency	50 - 60 Hz	50 - 60 Hz	50 - 60 Hz	50 - 60 Hz	50 - 60 Hz
Weight	8.2 kg	9.4 kg	9.5 kg	10.5 kg	6.5 kg
Noise level	31 dB(A)	31 dB(A)	30 dB(A)	30 dB(A)	36 dB(A)







## VISUALIZER

### The digital overhead projector

Visualizes paper documents, pictures and objects via PC and data/video projector  
Basic equipment of a modern classroom or lecture room

- Easy installation and operation
- Large image projection of small objects
- Video presentations of experiments
- Easy storing, printing or sending the results via e-mail

#### Technical data

Model	DC 120	DC 158	DC 166	DC 265	PS 650 / PS 660
Usage	Mobile	Mobile	Mobile	Mobile	Desktop
Illustration					
Ref. No.	7461 000 019	7461 000 020	7461 000 016	7461 000 017	7461 000 018 / 7461 000 015
Physical resolution	UXGA (1600 x 1200)	SXGA (1280 x 1024)	SXGA (1280 x 1024)	UXGA (1600 x 1200)	UXGA (1600 x 1200)
Image resolution	XGA, SXGA, UXGA	SXGA, XGA, WXGA	SXGA, XGA, WXGA	XGA, SXGA, UXGA, HDTV 720p/1080p	XGA, SXGA, UXGA, HDTV 720p/1080p
Picture sequence in seconds	30	30	up to 30	up to 30	up to 30
Integrated memory for photos	-	up to 120	up to 120	up to 240	up to 120 / up to 240
Slot for memory extension	-	-	SD slot, SDHC-compatible	SD slot, SDHC-compatible	- / SD slot
Rotating camera head	Swan neck	Swan neck	Swan neck	Swan neck	90°/180°/270°
Functions	Freeze, audio/video recording	Freeze	Freeze, video, text mode	Freeze, audio/video recording, text mode	Freeze / freeze, audio and video recording
Zoom	6 x mechanical	10 x digital, 20 x mechanical	5 x optical, 8 x digital, 14 x mechanical	6 x optical, 6 x digital, 14 x mechanical	15 x optical (PS 660), 12 x optical (PS 650) 6 x digital
Zoom / focus	Autofocus	Manual/autofocus	Motorized/autofocus	Manual/autofocus	Motorized/autofocus
Lights	1 LED lamp (integrated in head)	1 lamp (flexible) on swan neck	1 lamp (flexible) on swan neck	2 lamps (flexible) on swan neck	2 arms with lamps
Inputs	-	VGA	VGA	VGA	2 x VGA, 2 x audio, integrated MIC (PS 660)
Outputs	USB 2.0	VGA, USB, RS232, C-Video	VGA, USB, RS232, C-Video	2 x VGA, HDMI, RS232, C-Video, audio, USB	2 x VGA, C-video, RS232, USB, audio, HDMI
PC interface	USB 2.0	RS232, USB	RS232, USB	RS232, USB	RS232, USB
Max. working surface	420 x 315 mm	400 x 300 mm	420 x 315 mm	400 x 300 mm	355 x 266 mm
Dimensions	435 x 106 x 310 mm	450 x 140 x 400 mm	460 x 140 x 400 mm	432 x 211 x 559 mm	520 x 350 x 590 mm
Weight	ca. 1 kg	ca. 2.3 kg	ca. 2.3 kg	ca. 2.3 kg	ca. 5.5 kg
Package includes	Connection cables, software, IR remote control, microscope adapter, carrying bag	Connection cables, software, IR remote control, microscope adapter, carrying bag	Connection cables, software, IR remote control, microscope adapter, carrying bag, 512MB SD card	Connection cables, software, IR remote control, microscope adapter, carrying bag	Connection cables, remote control, quick start guide (PS 650), extender adapter, microscope adapter, quick manual (PS 660)



## DC 120

Uncomplicated light weight visualizer

- Easy installation via USB cable
- Image resolution from XGA to UXGA
- Audio/video recording via PC
- Built-in microphone and LED lamp

Visualizer DC 120	7461 000 019
-------------------	--------------



Kensington lock



USB 2.0



## DC 158 / DC 166

The versatile high performance visualizers

- High connectivity
- SD card slot (DC 166)
- C-video output for TV
- Picture-in-picture mode
- 5 x optical zoom (DC 166)

Visualizer DC 158	7461 000 020
Visualizer DC 166	7461 000 016



Connections DC 166



Connections DC 158



## DC 265

The MultiMedia visualizer

- UXGA resolution and 6 x optical zoom
- Audio/video recording with one button
- Cooperates with interactive whiteboards
- HDTV compatible

Visualizer DC 265	7461 000 017
-------------------	--------------



Connections DC 265



## PS 650 / PS 660 High resolution MultiMedia visualizers

- HDMI 1080 p output for highest quality demands
- SXGA image resolution
- 15 x optical zoom (PS 660), 12 x optical zoom (PS 650) USB high speed support
- Audio/video recording on memory card (DC 660 only)
- VGA switch with 2 VGA inputs and outputs
- Supplied with IR remote control

Visualizer PS 650	7461 000 018
Visualizer PS 660	7461 000 015



### Connections PS 660



**Slot**  
for IR remote control



**SD card slot**  
(PS 660)



**Large working surface**  
For objects up to  
DIN A 3 size

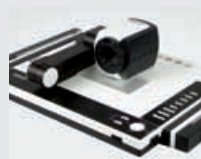

**Easy to transport**  
Folding arm



**Rotating camera**  
The camera can be rotated by 90°, 180° and 270°, the head can also be swivelled.

## ACCESSORIES



**Microscope adapter**  
for PS 650 / 660

7461 000 101



**Transport bag**  
for PS 650 / 660

7461 000 100



**Transport bag**  
for DC series

7461 000 102



**Transmissive unit**  
for visualizer

7461 000 103



**K**indermann

## DISPLAYS

Presentation solutions for entrance halls, conference rooms, point of information, point of sale

KINDERMANN distributes professional LCD displays by:

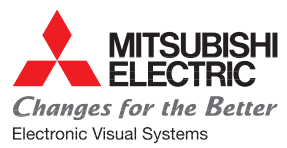

We offer a wide range of LCD displays from 32" up to 82" image diagonal:

Standard models, weatherproof models for outdoor use, robust models resistant against oil, smoke or dust for industrial use. You can find details about the latest models on our website [www.kindermann.com](http://www.kindermann.com) or on the original websites of the manufacturers:

- [www.sanyo.de](http://www.sanyo.de)
- [www.conrac.de](http://www.conrac.de)
- [www.mitsubishi-presentations.com](http://www.mitsubishi-presentations.com)
- [www.sharp.de](http://www.sharp.de)





## FOCUSTOUCH

Large format interactive LCD touch screen displays

Interactive presentations –  
easy to operate without many preparations

Focustouch is a series of interactive LCD displays on which presentations and applications can be directly controlled by a finger tip or a pen on the display.

Connect your LCD display with your computer or laptop, install the infrared touch driver, and you can start your presentation!

- 24 hour operation possible
- Sturdy materials for long life (50,000 hours)
- Vandalism proof – extremely strong tempered glass
- Very good image quality - full HD resolution
- Environmentally friendly due to low energy consumption

Compared with conventional solutions there are no problems with:

- Complicated focusing
- Room light and sun light
- Dazzling projector light
- High amount of maintenance
- Noise through projector fan
- Digital pen and batteries
- The lecturer's shadow on the projection screen



32 inch



Focustouch 32" interactive LCD display

42 inch

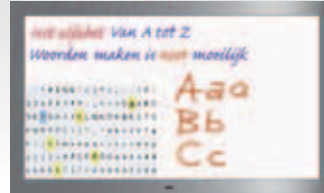

Focustouch 42" interactive LCD display

55 inch



Focustouch 55" interactive LCD display

65 inch



Focustouch 65" interactive LCD display

#### Technical data

Model	Focustouch 32" LCD Display	Focustouch 42" LCD Display	Focustouch 55" LCD Display	Focustouch 65" LCD Display
Ref. No.	3000 000 132	3000 000 133	3000 000 134	3000 000 135
Technology	LCD	LCD	LCD	LCD
Native resolution in pixels	1366 x 768	1920 x 1080	1920 x 1080	1920 x 1080
Format	16:9	16:9	16:9	16:9
Size of screen	698 x 393 mm	930 x 523 mm	1209 x 680 mm	1428 x 803 mm
Diagonal	32"	42"	55"	65"
Brightness cd/m <sup>2</sup>	500	500	500	450
Contrast	1500:1	1500:1	4000:1	2000:1
Response	6.5 ms	6.5 ms	4.5 ms	6 ms
Viewing angle	178°	178°	176°	176°
Computer VGA (analogue)	2 x HD 15	2 x HD 15	2 x HD 15	2 x HD 15
DVI / HDMI (digital)	1 x DVI	1 x DVI	1 x DVI	1 x DVI
RS 232 interface	1 x RS 232	1 x RS 232	1 x RS 232, 1 x RS 485 in/out	1 x RS 232
Loudspeaker integrated / optional	- / optional	- / optional	- / optional	- / optional
Picture in picture function	no	no	no	no
Special features	Touch screen with 4 mm safety glass	Touch screen with 4 mm safety glass	Touch screen with 4 mm safety glass	Touch screen with 4 mm safety glass
24 hour operation	yes	yes	yes	yes
Overall dimensions	815 x 506 x 110 mm	1045 x 638 x 126 mm	1367 x 839 x 156 mm	1561 x 918 x 143 mm
Net weight	32 kg	45 kg	65 kg	90 kg
Warranty	2 years bring-in	2 years bring-in	2 years bring-in	2 years bring-in



## DYNAMIC Monitor solution

The professional and well designed monitors of the Kindermann DYNAMIC series are perfect for an elegant integration in conference tables, interactive work places and video conference rooms.

They are available in different sizes, from 15" up to 22", and in two versions, with the monitors in upright position or tiltable by 20°.

### Available options:

- RS 232 control for monitor functions
- Touch screen
- Integrated video conference camera



Dynamic 1						
Ref. No.	5110 000 300	5110 000 320	5110 000 310	5110 000 330	5110 000 340	5110 000 350
Dynamic 2 (tiltable by 20°)						
Ref. No.	5110 000 360	5110 000 380	5110 000 370	5110 000 400	5110 000 390	5110 000 410
Technical data						
Image diagonal	15"	17"	17"	19"	19"	22"
Format	4:3	5:4	16:10	5:4	16:10	16:10
Native resolution	1024 x 768	1280 x 1024	1440 x 900	1280 x 1024	1440 x 900	1680 x 1050
Signal input	VGA (15pol)	VGA (15pol)	VGA (15pol)	VGA (15pol)	VGA (15pol)	VGA (15pol)
DVI			DVI-D		DVI-D	DVI-D
Brightness	500 cd/m <sup>2</sup>	300 cd/m <sup>2</sup>	250 cd/m <sup>2</sup>	250 cd/m <sup>2</sup>	300 cd/m <sup>2</sup>	300 cd/m <sup>2</sup>
Contrast	700:1	1000:1	800:1	800:1	800:1	1000:1
Control	Buttons for up/down on the unit, external control through contacts, RS 232 interface optional					
Housing	Sturdy housing of anodized aluminium. Upper cover plate of stainless steel, brushed finish. Electrical lift system with variable speed. Monitor tiltable up to 20° when lifted.					
Power supply	100-240 VAC, 50/60Hz - 12VDC, 5A					



## INTERACTIVE SYSTEMS

The ideal tool for new ways of presentation

Kindermann distributes products by Polyvision and focusses on the promotion of ēno, the ultimate whiteboard. ēno is a classic whiteboard, but in combination with a data/video projector and a bluetooth pen it becomes an interactive whiteboard.

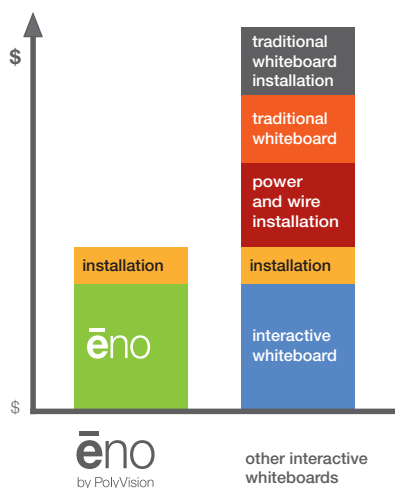

### Only ēno

ēno is compatible with computers running with Microsoft Windows or Mac OS. You can use either WizTeach or any educational software, or the web browser, Microsoft PowerPoint and many others.

ēno does not require any installation measures, no cables for electricity or data transfer.

ēno is characterized by three special features:

#### 1. Surface can be dry-wiped

Write with ordinary felt pens and dry-wipe the surface afterwards.



#### 2. Magnetic „e3-environmental ceramicsteel“

Gives students the opportunity to work with magnetic symbols without damaging the surface.



#### 3. Interactive functions

The bluetooth pen, a PC and a data/video projector make the board interactive.



Please visit our website or ask us for more information about the available models and accessories.



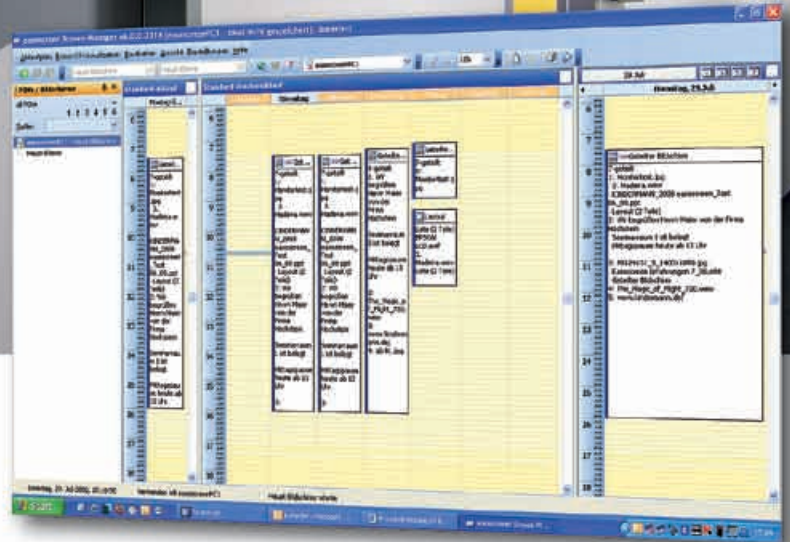

## eas@screen

### Content management system for digital signage

**Content management system for digital signage, which can be operated intuitively and which presents and manages different contents on an individual number of displays.**

easescreen can be configured individually, i. e. the Windows based software adapts to your needs. No matter whether you need a stand-alone solution for your sales room or have to feed a global network with advertisements, eas@screen is the proper choice. The flexibility of the software also allows you to present local information.

### Features and functions

- Management of the whole presentation in a calendar layout (similar to Outlook). In this schedule the contents are defined and arranged chronologically.
- The programme can be operated from different locations and terminals simultaneously.
- Recurring events (daily / weekly) but also events at a certain time and date can be programmed in advance.
- The programmes can be stored.
- Templates make it possible to create complex pages with an editor (e.g. Word), which, with the help of placeholders, can be directly supplemented in eas@screen with the proper contents.
- Complete remote control of client PCs, no local user interaction required.
- Control of the clients via network (web browser) and SNMP.
- Integration of news tickers "RSS Feeds" from the internet.
- Lots of possibilities for interaction, e.g. via touch button, touch screen, motion sensor etc.
- For a detailed list of functions visit our website [www.kindermann.com](http://www.kindermann.com)

### Transparency

- eas@screen Crystal creates flexible levels of transparency among all types of files (requires 3D Direct compatible PCs with suitable hardware).

### Supported display and file formats

- Microsoft Powerpoint presentations
- Adobe Flash (swf), Shockwave Director (dcr), Adobe PDF
- Almost all image formats, e.g. jpg, bmp, png, tiff, tga
- PDF files (from version 7 on)
- TV (analogue or digital DVB-S/T), video text, video input
- Internet/Intranet pages, automatic refresh and scrolling possible
- Video files, e.g. mpg, avi, asf, vob, wmv, divx, mov., etc.
- Streaming video
- Web archives mht and html. With this format all office documents can be visualized, e.g. Word, but also contents from all other programmes that can create HTML files.
- External video/signal sources directly connected with the display/projector (start/stop of video recorders, e.g.)
- Visualization of individual data makes it possible to present contents from data banks and external data sources/connected players.

## easescreen versions

The software is available in different versions and with different performances.

The content management software easescreen consists of two parts. The easescreen screen manager is the editor software with which the contents are arranged, programmes are made and displays are managed. The easescreen POV client is installed on the player PC and automatically follows the programme which was made with the editor software. The individual formation of client groups makes the efficient management of different display contents possible. Only for an update of the display contents is a network connection between manager and client necessary.

easescreen Crystal is a more sophisticated version of the standard software, which creates flexible levels of transparency among all types of files. E. g. half-transparent videos or images can be superimposed or newstickers or texts can be running at the bottom of the screen. These functions are based on Direct3D by Microsoft and require a sufficiently powerful graphic hardware.

Functions which were not required at the time of the initial installation can be acquired via a licence code and implemented later.

### easescreen software packages

easescreenB asic	8734 000 001
easescreenS tandard	8734 000 002
easescreenS tandardC RYSTAL	8734 000 012
easescreenP remium	8734 000 003
easescreenP remiumC RYSTAL	8734 000 013

## Why easescreen?

### Variety of formats

easescreen can display nearly all common PC based file formats.

### Easy operation

Intuitive operation. The user interface is similar to the "look and feel" by MS Outlook.

### Preview function

The screen manager offers a preview of what is shown on the display. Screen shots and status information of the client can be displayed at any time.

### Flexible layout

The screen manager allows you to do the screen layout individually. All available contents (files, web, films, TV etc.) can be activated simultaneously.

### Display levels

An individual number of definable levels can be created to separate the layout from the content and the user authorization.

### Display logging

All displayed media files are automatically logged!

### Interactive events

In public transport, e.g., stops can be faded in, or in a do-it-yourself market the customer can start product videos by pressing a button.

### Control of the projection units

easescreen automatically switches displays and projectors on and off. It also controls the operation of the units.

### Redundancy

The media files and the programme lists are stored on the editor PC as well as on the client PC.

### Data bank connectivity

easescreen allows the user to connect external data sources, e.g. to have access to control systems. Information from data banks can be integrated, individual functions can be configured and realized.

### No servers

The management in small installations is done via the screen manager without additional server.

The screen manager can be installed as often as required, several users can process contents simultaneously (depending on version).

For larger networks (> 30 clients) the easescreen management server in addition to the screen manager is recommendable. It takes over the communication with the single clients, supervises their function, services the operation system and offers extended account and alarm functions.

### Easy installation / low hardware requirement

The installation (servicing/upgrades) of easescreen is very easy.

Typical player PC installations can be done in less than 30 minutes. Suitable pre-configured PCs can be offered on demand.

### Multi display

Enables the user to control up to four displays from one single PC.

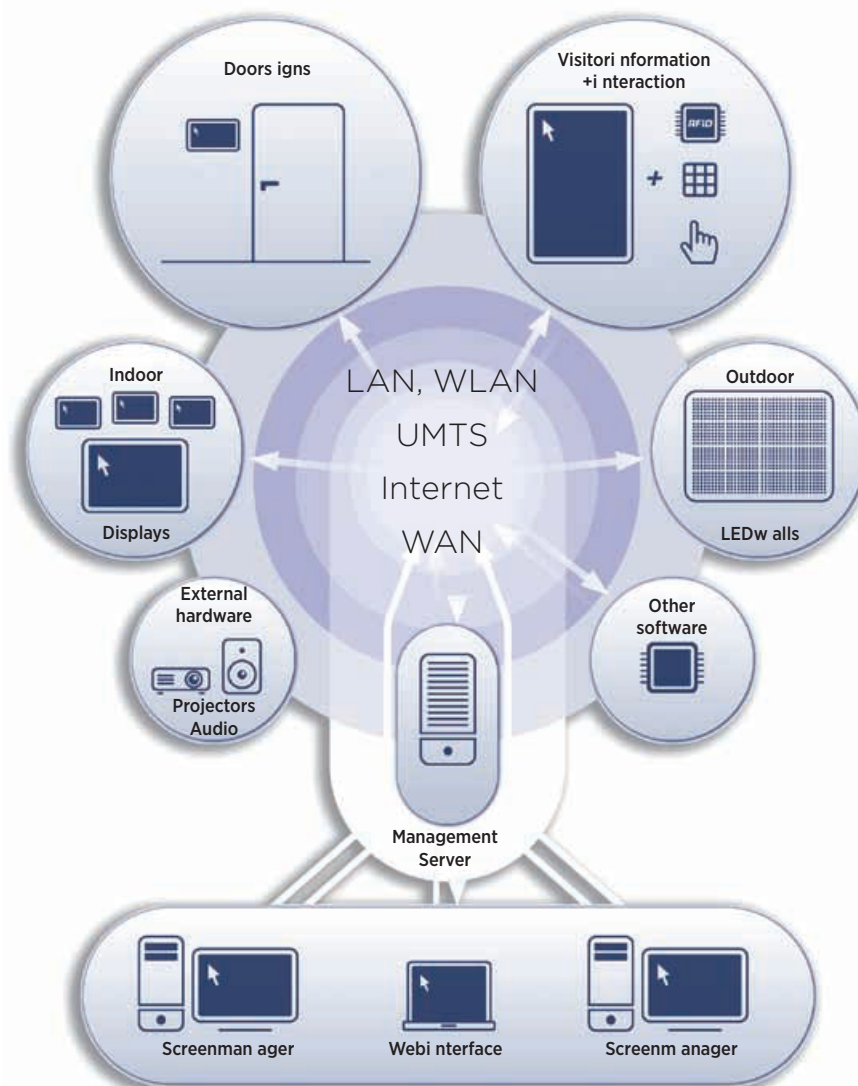



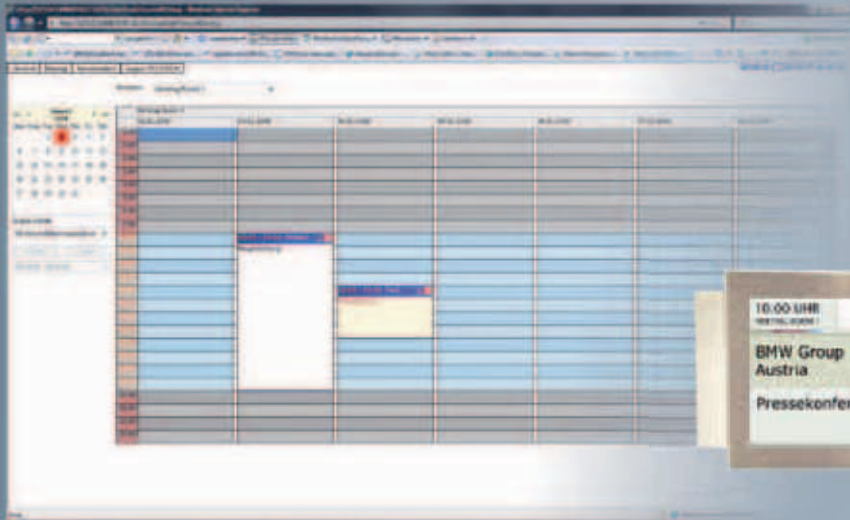

## ESIGN

### Fields of application:

- Convention centres, seminar centres
- Universities, schools
- Hotels

Esign is a special version of the digital signage software. It is a room booking system which automatically sends the information to the displays or information terminals in entrance lobbies or in front of conference rooms.

All the contents and layouts can easily be determined individually.

- Exhibitions
- Public buildings, authorities

The programming of room bookings is done via a separate HTML page. According to the programming the wall displays and terminals are automatically fed with the data.

easescreen is compatible with all standard databank formats and room booking systems (Access, Outlook/Exchange, Fidelio, etc.).



Software	Ref. No.
easescreen Esign server	8734 000 004
easescreen Esign POV client	8734 000 005

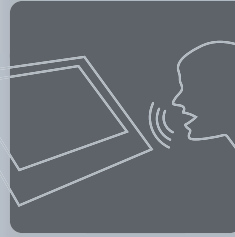

## EVA

### Your virtual receptionist

- Interactive 32" monitor with touch panel
- Stereo sound system with integrated microphone
- Free access
- Motion sensor for activating the system

### Ideal for visitor reception

- Information terminal and visitor guide at events
- Interactive information terminal for floor plans, catalogues etc.
- Due to the telephone function you can get in touch with the secretary, the hotline, the event management, the taxi driver, the ambulance or other addresses.
- True eye catcher due to individual colour design of the light pillar.

### Interactive information terminal

EVA, the interactive personal guide, provides you with information and serves as direct access to your telephone network.

Due to the integrated VoIP client you do not need a telephone interface - mains supply and a network connection are sufficient.

EVA is supplied with a custom-made software by Kindermann.

This software based on Windows interactively supports the following components: e.g. motion sensor, touch screen and the audio system.



#### Example of a configuration:

"EVA" with Illumination 32 as hardware platform.  
Other configurations available on demand.



# DOORSIGNS

Room information systems



## DoorSign 7"

**Our "baby".** The perfect display solution for our E-Sign room booking server when it comes to putting up uncomplicated signs for rooms and corridors. Easy to mount due to PoE. Because of LED technology and a maximum output of 7 Watt the DoorSign 7" realizes the idea of "Green IT".

Versatile, compact, low cost and nevertheless high quality.

- Standard frame: plastic, silver
- Brightness and temperature sensor
- Touch screen



### Accessories

Illustration	Model	Ref.No .
	Front anodized aluminium, for DoorSign 7"	5000 000 051
	Front genuine glass, white, for DoorSign 7"	5000 000 052
	Front genuine glass, black, for DoorSign 7"	5000 000 053

## DoorSign 12" with integrated PC

**The power model.** By installing the E-Sign server software in the DoorSign 12", more LCDs can be connected as clients. This model is also very suitable for digital signage because of its powerful hardware and operation system. It can be used for in-wall or on-wall mounting.

- Digital DoorSign with stainless steel frame
- Integrated high performance PC
- Windows 7 Pro



### Technical data

Model	DoorSign7"	DoorSign12 "
Ref.No .	5000 000 050	5000 000 010
Size of display diagonal	7"	12"
Resolution	800 x 480	800 x 600
Format	16:9	4:3
PC configuration	ARM9 400 MHz CPU, 128 MB system memory front USB interface	Intel Atom 1.6 GHz with 945GSE chip set and 950 graphic card, 1 GB RAM
Memory	128 MB memory	60 GB hard disc
Operatings ystem	Windows CE 5.0 Pro	Windows 7 Pro
Connections	1 x LAN (PoE), 1 x USB, 1 x RS232 or RS 422/485	1 x PS/2, 1 x VGA, 2 x Gigabit LAN, 2 x USB
Mounting	In-wall	In-wall / on-wall
Packagei ncludes	Touch pen	Power supply





## DoorSigns with integrated PC

**The family.** These DoorSigns models can be used as door, floor or lobby signs. They can be mounted in-wall or on-wall and feature an integrated PC, which can be individually configured, and a high-quality full glass front. Thus they create a harmonious atmosphere, e.g. in an office building.

- Digital door sign for in-wall or on-wall mounting
- Optional stainless steel frame or full glass front
- Integrated PC with Windows XP embedded, integrated power supply



### Accessories

4 GB-CF card instead of 2 GB as memory (against surcharge)	5000 000 021
8 GB-CF card instead of 2 GB as memory (against surcharge)	5000 000 022
2 GB RAM instead of 1 GB (against surcharge)	5000 000 024
Win XP Pro and 160 GB hard disc instead of CF card and WinXP embedded (against surcharge)	5000 000 025

### Options

Bracket for on-wall mounting
In-wall frame
Resistive touch

Insert unit into installation frame



Let it engage



Finished!



Model	DoorSign10"	DoorSign15"	DoorSign19"	DoorSign24"	DoorSign32"	DoorSign42"
<b>DoorSigns with full glass front</b>						
Ref.No .	5000 000 003	5000 000 004	5000 000 006	5000 000 007	5000 000 008	5000 000 009
<b>DoorSigns with stainless steel frame</b>						
Ref.No .	5000 000 013	5000 000 014	5000 000 016	5000 000 017	5000 000 018	5000 000 019
<b>Technical data</b>						
Size of display diagonal	10"	15"	19"	24"	32"	42"
Resolution	1024 x 768	1024 x 768	1280 x 1024	1920 x 1080	1920 x 1080	1920 x 1080
Format	4:3	4:3	4:3	16:9	16:9	16:9
PC configuration	INTEL ATOM N270 (1,6 GHz) with 945 GSE chip set and GMA 950 graphic card, 1 GB RAM			INTEL Celeron 570 (2,26GHz) with GME 965 chip set and GMA X3100 graphic, 1 GB RAM		
Memory	2 GB CF card					
Operating system	Windows XP embedded					
Connections	1 x VGA (HD15), 1 x RS232, 2 x USB 2.0, 2 x GBit-LAN					



# DESIGN 32V/DESIGN 40V/LSIGN 32

The high-performance designer display

- Designer displays for the conference room
- Sturdy metal casing with 32"/40" LCD display
- Integrated multimedia PC, sound unit and optional motion sensor
- Also available as touch screen display
- 52" display on demand

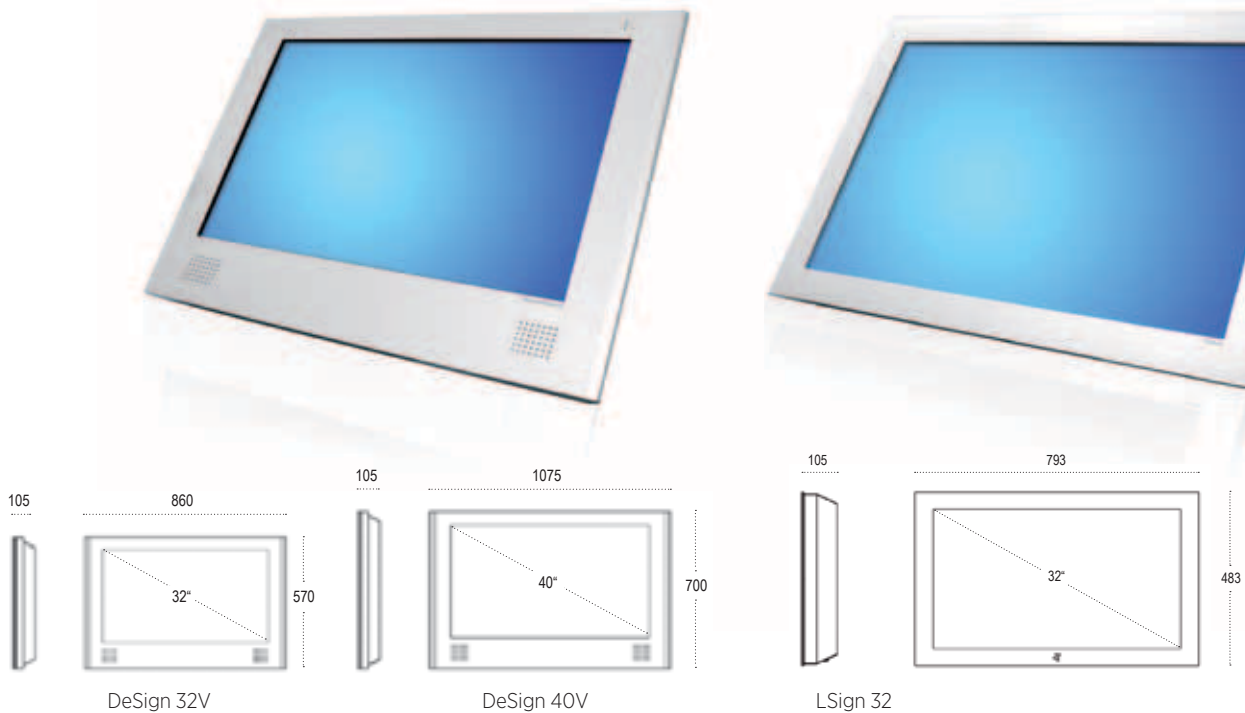

The 4.7 cm thin side section of the DeSign 32V/40V is decorated with a chromium-plated rail.

The scratch-resistant anodized aluminium casing is closed and therefore especially protected against vandalism.

A powerful multimedia PC can be integrated in the casing of the DeSign 32V/40V.

Due to its modular structure the information terminal can be supplemented by a touch screen, an audio module and a motion sensor.

The display can be mounted on the wall or on the ceiling. This makes it suitable for exhibitions and road shows..

Technical data			
<b>Model</b>	DeSign 32V	DeSign 40V	LSign 32
<b>Ref. No.</b>	5000 000 210	5000 000 220	5000 000 200
<b>Size of display</b>	32"	40"	32"
<b>Resolution</b>	1360 x 768 pixels	1920 x 1080 pixels	1360 x 768 pixels
<b>Dimensions</b>	860 x 570 x 105 mm	1075 x 700 x 105 mm	793 x 483 x 105 mm
<b>Weight</b>	37 kg	45 kg	32 kg
<b>Design</b>	<ul style="list-style-type: none"> <li>• Elegantly designed casing</li> <li>• Front side anodized aluminium</li> <li>• Chromium-plated side sections</li> <li>• Brilliant 32" or 40" display</li> <li>• Integrated HiFi speakers (only with 32" and 40")</li> <li>• Microsoft Windows XP (pre-installed)</li> <li>• Additional VGA input for external PCs and remote control</li> <li>• Latest powerful multimedia PC with "electronic stability programme"</li> </ul>		
<b>Other features</b>	<ul style="list-style-type: none"> <li>• "easescreen software package"</li> <li>• Touch screen</li> <li>• Network connection via radio (wireless LAN)</li> <li>• Terminal in individual RAL colours</li> <li>• Other options on demand</li> </ul>		

# ILLUMINATION 32/40

## The interactive light pillar

- Combination of an interactive designer display and a light pillar
- Monitor with touch screen function and integrated PC
- True eye catcher due to individual colour design of the light pillar
- Ideal as stand-alone solution, e.g. at exhibitions

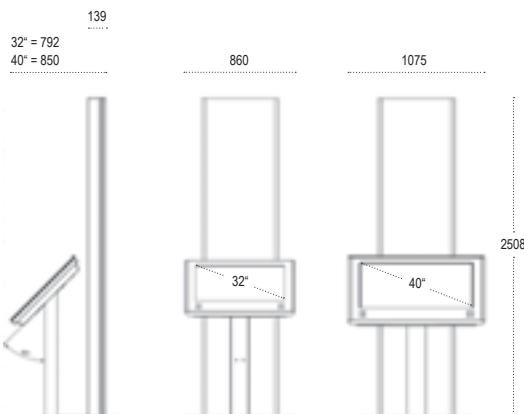

The illumination 32/40 helps you to send your messages effectively to the public or your customers due to elegant colour and light effects.

The elegantly designed pillar features a conspicuous and pleasant ambience illumination in various colours, e.g. those of your company.

The side sections in anodized aluminium of the light pillar are only 5 cm thin and decorated with elegant chromium-plated rails.

The illumination 32/40 is equipped with large 32" or 40" displays with wide viewing angles. As stand-alone solution the terminal is ideal for using it at exhibitions, e. g.

All models are available with integrated PC. Moreover, they can be attached to all external standard multimedia PCs. The modular structure of the system stands for maximum flexibility.

Technical data		
<b>Model</b>	<b>illumination 32</b>	<b>illumination 40</b>
<b>Ref. No.</b>	<b>5000 000 130</b>	<b>5000 000 140</b>
<b>Size of display</b>	32"	40"
<b>Resolution</b>	1360 x 768 pixels	1920 x 1080 pixels
<b>Dimensions</b>	860 x 2508 x 792 mm	1075 x 2508 x 850 mm
<b>Weight</b>	110 kg	120 kg
<b>Design</b>	<ul style="list-style-type: none"> <li>• Elegantly designed casing</li> <li>• Front side anodized aluminium</li> <li>• Chromium-plated side parts</li> <li>• Bottom plate with display holder for stability of the whole unit</li> <li>• Light pillar for advertisements in different colours</li> <li>• Elegant 32" or 40" display</li> <li>• Integrated HiFi loudspeakers / ultra-sound motion sensor</li> <li>• Latest powerful multimedia PC (optional)</li> </ul>	
<b>Other features</b>	<ul style="list-style-type: none"> <li>• „easescreen software package“</li> <li>• Microsoft Windows XP (pre-installed)</li> <li>• Touch screen</li> <li>• Network connection via WLAN</li> <li>• Telephone options (analogue and VoIP)</li> <li>• Individual designing of the light pillar, e.g. with your company logo</li> <li>• Further options on demand</li> </ul>	

# IMPRESSION 32L / 40 / 52

## The characteristic presenter

- Elegant terminal for your messages at the POS/POI
- Surface of anodized aluminium
- Available in 32" landscape format or 40" and 46" portrait format
- High contrast and light output
- Motion sensor for approaching visitor (optional)

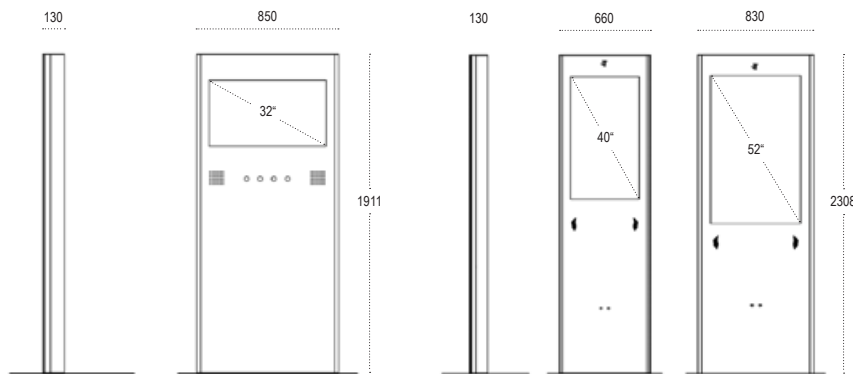

Due to its brilliant large display with a high light output and contrast and its integrated HiFi speakers the terminal raises special attention on exhibitions and other events, in entrance lobbies and lounges.

The sensor-controlled presentation of your messages addresses the visitors directly.

Moreover, the slim anodized aluminium casing of the elegant terminal gives your presentations a special note.

The system is extremely sturdy and can therefore be operated anywhere.

Technical data			
Model	impression 32L	impression 40	impression 52
Ref. No.	5000 000 100	5000 000 110	5000 000 250
Size of display	32"	40"	52"
Resolution	1366 x 768 pixels	1080 x 1920 pixels	1080 x 1920 pixels
Dimensions	850 x 1911 x 130 mm	660 x 2305 x 130 mm	830 x 2308 x 130 mm
Weight	80 kg	80 kg	110 kg
Design	<ul style="list-style-type: none"> <li>• Elegantly designed casing</li> <li>• Front side of anodized aluminium</li> <li>• Chromium-plated side parts</li> <li>• Bottom plate for stability of the whole unit</li> <li>• Elegant 32", 40" or 52" display</li> <li>• Integrated HiFi loudspeakers / ultra-sound motion sensor</li> <li>• Latest powerful multimedia PC with "electronic stability programme"</li> <li>• Microsoft Windows XP Professional (pre-installed)</li> </ul>		
Other features	<ul style="list-style-type: none"> <li>• "easescreen software package"</li> <li>• Touch screen</li> <li>• Terminal in individual RAL colours</li> <li>• Individual designing of the system, e.g. with your company logo</li> <li>• Network connection via radio (wireless LAN)</li> <li>• Telephone options (analogue and VoIP)</li> <li>• Webcam</li> <li>• Magazine holder (attached)</li> <li>• Other options and sizes on demand</li> </ul>		



## VIDEO COMMUNICATION

The modern video conference is based on the principle of "who with whom".

No matter whether it is a PC client or a room system, the infrastructure solutions that Kindermann offers are an ideal link between the manufacturers and the systems.



### SCOPIA® – a revolutionary step forward in video conferencing

There are various ways to get in touch with one another, no matter where in the world and how. You can always be present via video conference.

SCOPIA® makes it possible!

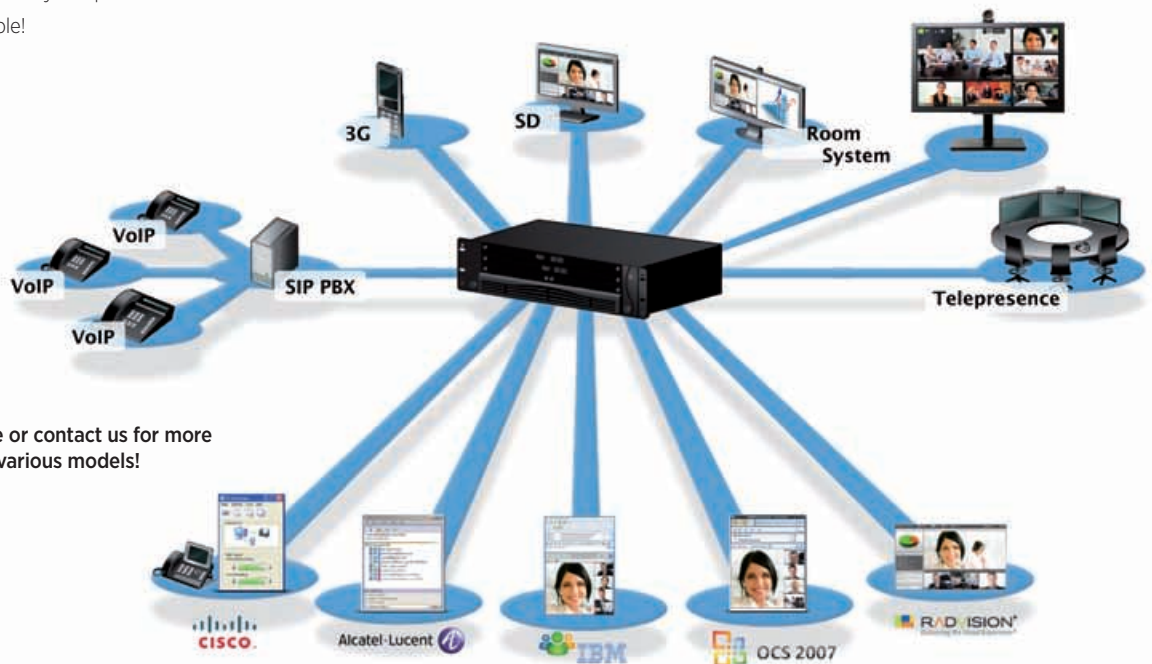

Please visit our website or contact us for more information about our various models!



## MULTIMEDIA FURNITURE

### Video conference tables

An intelligent signal management and connection ports in the desktop allow the participants to plug in their notebooks directly.



Plain fronts

Lift for technology



### Mobile video communication

This video conference and monitor solution supports presentations, seminars, consultations etc.

In spite of its size its mobility is guaranteed. Because of the integrated lift the monitor is height-adjustable so that the terminal fits through normal doors. Due to its big heavy-duty castors the terminal can even be moved across uneven floors.

## PLANNING – OUR SERVICE

### Two modes of planning – unlimited solutions

We analyse the ideas and demands of our customers and develop appealing concepts for the furnishing and technical equipment.

**Along with it we offer the necessary professional planning staff you need:**

Interior designers and engineers who provide you with the latest hardware and software.

**P 1 – Basic planning**

**P 2 – Full planning package for more sophisticated demands**

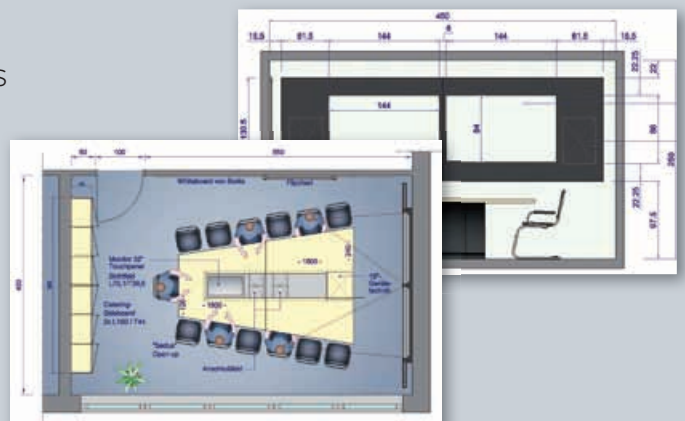



## MultiMedia sideboards

Whether used for video communication or presentation, whether installed in the CEO's office or in a conference room – the MultiMedia sideboard is designed for higher demands.

Depending on their application MultiMedia sideboards are equipped with monitor lift, electrically operated projection screen and integrated wide angle projector. They are also available with room for a mobile MultiMedia terminal.

## MultiMedia wall

For video conferences and presentations, designed for the integration of flat screen displays and video camera.



## Mobile MultiMedia furniture

Plain design, high functionality and high quality materials work together with the latest communication technology and turn media furniture into MultiMedia terminals.

One basic module - several applications:  
e. g.

- as monitor trolley with electrically operated fold-away screen
- as mobile projection unit with built-in projection module
- as mobile catering unit with minibar
- as mobile store room



## P 1 – Basic planning

- Specific room use and various furnishing options along with audio-visual media technology
- Analysis of requirements
- Exact floor plans
- Various furnishing options
- Assembly of technical components

## P 2 – Full planning package

- Planning package with different synchronized planning elements, e.g. specific room use and various furnishing options along with audio-visual media technology
- Coloured floor plans and side views
- Samples of colours and materials
- Planning of ceiling construction and room lights
- Floor plan with floor boxes
- Wiring plans
- Circuit diagrammes

## You want to know more?

Please contact us for more detailed information about our MultiMedia furniture and services.

# MULTIMEDIA DESK FOR SCHOOLS

Lecturing and presenting in one go

- Intelligent all-inclusive solution for MultiMedia presentations
- Teacher's desk with the complete MultiMedia technology and space for more
- System fully wired
- Ready for use within 60 seconds
- Premium piece of furniture for longterm use
- Protected against vandalism: completely lockable

The Kindermann MultiMedia desk is an innovative teacher's desk. It has been designed to meet the demand of modern school education.

The MultiMedia desk includes a PC (not included in the standard package), a display, a sound system and a projector.

The whole unit is connected to the mains with only one power cable. To connect various external devices (notebook, USB memory, school network, printer etc.) there are two integrated connection ports on the left and right side of the desk.

All units are installed in the lockable desk, completely wired and thus protected against manipulation or theft.

When the projector flap is opened, the projector is automatically switched on. In no time can presentations be projected on a large screen by the integrated unit, e.g. texts from the PC resp. USB memory, films from the DVD player, data from the school network or internet etc.

An additional pro: The 17" display integrated in the desktop behind safety glass allows the teacher to follow the projection without losing sight of his class.

After the presentation, the flap is closed and the projector automatically switches to standby mode. Thus the furniture can be used as a conventional desk which offers additional room for storing teaching material or other equipment in one of the lower compartments.

The Kindermann MultiMedia trolley is the mobile version, but without display and lower storage compartment.



Optional deposit tray

## A lot of room for technical devices



Lockable compartment with adjustable shelf. Space for audio system and mini PC

## Integrated display



The teacher can follow the projection on the monitor integrated in the desk without losing sight of his class

## Protected projection



When the flap is opened, the projector is automatically switched on. When the flap is closed, the projector automatically switches to standby mode



**Standard decor**

- Beech



**Other decors on demand**

- Birch



- Anthracite



**MultiMedia connection ports**



Built-in connection port on the left and right side of the desk for printer, scanner, overhead projector etc., incl. USB memory or network access, as well as two integrated mains sockets

**Kindermann MultiMedia desk**

MultiMedia desk with integrated TFT display, double mirror projection flap, two lockable compartments



**Features**

Multiplex plates, galvanized steel frame RAL 9003

- **Data/video projector**  
XGA resolution, ca. 2600 lumens, e.g. Kindermann KX 3200\*
- **Monitor**  
17" LCD monitor, 1280 x 1024 pixels, behind non-reflecting safety glass according to DIN 1249
- **Audio system 2.1**  
Stereo, 2 loudspeakers and subwoofer
- **2 MultiMedia connection ports**  
Mains connection with switch and 5.5 m cable, 3 mains sockets  
Connections for: computer IN (VGA), Audio IN, microphone IN, 3 x USB.  
Inside: Multiple socket for 6 x mains, concealed wiring for all devices
- **Dimensions**  
ca. 72 x 150 x 72 cm
- **Compartment right side**  
ca. 38 x 48 x 35 (45) cm, 1 height-adjustable shelf for DVD/VHS combi player\*, PC\*\* (not supplied)
- **Compartment left side**  
Drawer: ca. 12 x 17 x 45 cm, cabinet: ca. 36 x 24 x 45 cm, 1 height-adjustable shelf
- **Power supply**  
230 V, max. 2000 W

**Kindermann MultiMedia trolley**

Lockable MultiMedia trolley with double mirror projection flap and lockable media compartment



**Features**

Multiplex plates, galvanized steel frame RAL 9003, 4 lockable castors

- **Data/video projector**  
XGA resolution, ca. 2600 lumens, e.g. Kindermann KX 3200 active\*
- **Audio system 2.1**  
Stereo, 2 loudspeakers and subwoofer
- **2 MultiMedia connection ports**  
Mains connection with switch and 5.5 m cable, 3 mains sockets  
Connections for: computer IN (VGA), Audio IN, microphone IN, 3 x USB  
Inside: Multiple socket for 6 x mains, concealed wiring for all devices
- **Dimensions**  
ca. 72 x 62 x 72 cm
- **Usable space inside**  
ca. 38 x 48 x 35 (45) cm, 1 height-adjustable shelf for DVD/VHS combi player\*, PC\*\* (not supplied)
- **Power supply**  
230 V, max. 2000 W

<b>MultiMedia desk, incl. projector</b>	<b>7000 000 000</b>
<b>Deposit ray, to be attached to the MultiMedia desk</b>	<b>7009 000 000</b>
<b>MultiMedia trolley, incl. projector</b>	<b>7001 000 000</b>

\* Various data/video projectors, DVD/VHS combi players fit in.  
\*\* We recommend a Mini-PC (e. g. ShuttleR XPC, Barbone system), which can be built in on demand. Dimensions, design and technical data may change without prior notice.



# MULTIMEDIA TROLLEY “EDUCATION”

Lockable trolley on 4 castors

The plug and play media trolley can hold your complete presentation technology from the data/video projector to the audio system.

One minute after switching on the system the projection can start.

In no time can you prepare a conference room for an audio-visual lecture.



## THE MODELS

### MultiMedia trolley “Education”

**Basic module - PG1**

**5310 MWE 101**

Without technical equipment, mobile through four castors, two of them lockable (soft castors for hard floors, e.g. wood, etc., hard castors for soft floors, e.g. carpet). Removable back wall (punched steel) for installation and maintenance.

Projector shelf on top, extendable trays for laptop and visualizer on both sides.

Front with easy-going, lockable roller blind with stop function to prevent unauthorized persons from tampering with the technology and as dust protection for the MultiMedia units.

Mobile and flexible due to handles welded together with the steel frame. Body with melamine resin laminate inside and outside, and ABS-resin edges, maple decor, metal parts anodized RAL 9006, roller blind silver.

### Advanced module 1 - PG1

**Advanced module 1 - PG1**

**5310 MWE 121**

As basic module, but with additional basic technical equipment: Multiple socket for 6 x mains, internal wiring, audio system 2 x 25 W with 2 stereo speakers in projector shelf, connection port on the outside (mains connection with switch, mains socket, VGA, audio in, USB, LAN).

### Advanced module 2 - PG1

**Advanced module 2 - PG1**

**5310 MWE 131**

As basic module, but additionally equipped with subwoofer.

### Advanced module 3 - PG1

**Advanced module 3 - PG1**

**5310 MWE 141**

As basic module, but with audio system, completely equipped with microphone and satellite speakers.



## MultiMedia trolley "Education"

### Dimensions with castors:

65 x 60 x 110 cm

### Inner dimensions:

For projectors up to max. 40 x 30 x 15 cm

Laptop tray up to ca. 35 x 30 x 6 cm

Tray for visualizer up to ca. 35 x 30 cm

Lower compartment inside dimensions 50 x 45 x 50 cm with one adjustable shelf

## Accessories

**19"r ails**

**5310 MWE 111**

To be installed in the media trolley for integrating 19" unit

(All modules without the units shown in the illustration)

## B-LINE OPTIONS

### Range of colours\*

Choose from our B-line the colour that suits your surroundings best. The standard colour is RAL 9006, white aluminium with maple decor.

The following colours and decors are available at extra charge:

- RAL 3003 **ruby red**
- RAL 5002 **ultra marine**
- RAL 5014 **pigeon blue**
- RAL 5015 **azure**
- RAL 6005 **moss green**
- RAL 7022 **umbra grey, structure**
- RAL 7036 **platinum grey**
- RAL 9005 **deep black**



### Range of decors



- platinum grey
- ash white
- beech
- ash black

## B-LINE

### OHP projection trolley

Sturdy steel tube construction, RAL 9006 white aluminium, wooden surface in ash decor. Other decors available at extra charge\*.

- Cutout for OHP: 43 x 54 cm
- Dimensions: 60 x 59 x 75 or 100 cm
- With 4 castors, 2 of them lockable



OHP projection trolley, height 75 cm	5000 000 510
OHP projection trolley, height 100 cm	5000 000 513

### DVP projection trolley

Sturdy steel tube construction, RAL 9006 white aluminium, wooden surface in ash decor. Other decors available at extra charge\*.

- Deposit tray: 44 x 30 cm
- Working surface with cable outlet
- Dimensions: 60 x 59 x 75 or 100 cm
- With 4 castors, 2 of them lockable



DVP projection trolley, height 75 cm	5000 000 511
DVP projection trolley, height 100 cm	5000 000 514

## BUSINESS CLASS FURNITURE

### DVP projection trolley, tiltable

Sturdy steel tube construction, RAL 9006 white aluminium, wooden surface in ash decor. Other decors available at extra charge\*.

- Deposit tray: 44 x 30 cm
- Working surface with 10° height adjustment and cable outlet
- Dimensions: 60 x 59 x 75 or 100 cm
- With 4 castors, 2 of them lockable



DVP projection trolley, tiltable, height 75 cm	5000 000 512
DDVP projection trolley, tiltable, height 100 cm	5000 000 515

### Lectern

- Delivered fully mounted
- Dimensions: 68 x 43.5 x 116 cm
- Colour and type of wood selectable at extra charge\*
- Back wall available with door at extra charge
- Cable port can be integrated in desktop at extra charge
- With 4 castors, 2 of them lockable



Lectern	5000 000 500
Surcharge for cable port outlet	5000 000 501
Surcharge for back wall with door	5000 000 502

### Flipchart Deluxe

- Magnetic surface 96 x 69 cm
- For dry wiping
- Paper holder extendable on the left or right hand side
- Quick-change holder for paper pads
- Height-adjustable from 125 to 200 cm
- 2 castors



FlipchartDe luxe	4538 000 000
Flipchartp ad 20 sheets, 5-pack	6917 000 100

### Flipchart

Height-adjustable flipchart with hydraulic cylinder.

- Surface also suitable as whiteboard for dry-wipe markers
- Rack RAL 9006
- With 4 castors, 2 of them lockable



Flipchart in RAL 9006	4644 000 101
Flipchartp ad 20 sheets, 5-pack	6917 000 100



# S-LINE PROJECTION TROLLEYS FOR SCHOOLS

## The basic model

OHP trolley with tray 38 x 39 cm.

- Surface colour: light grey
- Dimensions: 38 x 40.5 x 62/100 cm
- Weight: 7 kg
- With 4 castors, 2 of them lockable
- Supplied in pieces



The basic model

6293 000 002

## The flexible model

OHP trolley with centre tray 45 x 45 cm and two adjustable side trays.

- Surface colour: light grey
- 2 deposit trays: 45 x 30 cm each
- Dimensions: 45 x 45 x 68/109 cm
- Weight: 13 kg
- With 4 castors, 2 of them lockable
- Supplied partly mounted



The flexible model

6295 000 100

## The bestseller model

Projection trolley of steel tube construction. With cutout (ca. 42 x 53 cm) for overhead projectors.

- Surface colour: light grey
- Dimensions: 60 x 70 x 75/120 cm
- Weight: 17 kg
- With 4 castors, 2 of them lockable
- Supplied fully mounted



The bestseller model

6535 000 100

## The comfortable model

Sturdy projection trolley with optional deposit tray. With cutout (ca. 43 x 54 cm) for overhead projectors.

- Surface colour: light grey
- Size of projector tray: 54 x 63 cm
- Dimensions: 68 x 59 x 73/100 cm
- Weight: 28 kg
- With 4 castors, 2 of them lockable
- Supplied fully mounted



The comfortable model

6524 000 000

# S-LINE PROJECTION TROLLEYS FOR SCHOOLS

## The DVP model

Projection trolley for data/video projectors and visualizers.  
Tilttable projector tray 40 x 50 cm with safety rail.

- Optional deposit tray for accessories 40 x 32 cm
- With 4 castors, 2 of them lockable
- Size of base: 54 x 63 cm
- Weight: 13 kg
- Supplied fully mounted

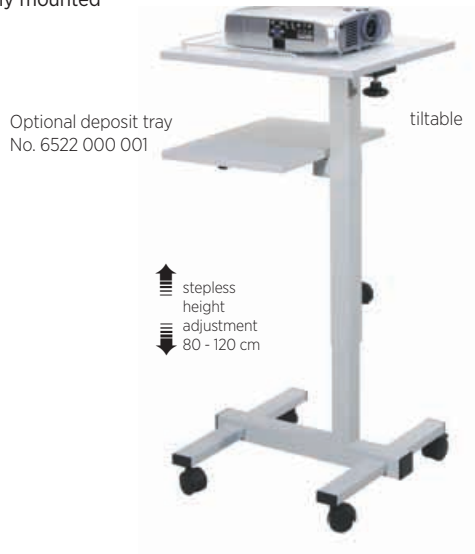

The DVP model	6522 000 000
Deposit tray 40 x 32 cm	6522 000 001

## The allround model

Projection trolley with tilttable working surface 39 x 63 cm.  
Extendable tray 44 x 47 cm, deposit tray 45 x 47 cm.

- Surface colour: light grey, RAL 7035
- Inc. triple socket with 5 m cable
- Dimensions: 89 - 115 x 45 x 69 cm
- With 4 castors, 2 of them lockable
- Weight: 35 kg
- Supplied fully mounted



The allround model	6526 000 001
--------------------	--------------

# PRESENTATION FURNITURE IN GLASS DESIGN

## Lectern

**Chromium-plated steel tripod with glass tray 48 x 36 cm**

- Height-adjustment: 105 - 145 cm
- Lower tray 50 x 26.5 cm, height-adjustable, can be swivelled
- 5 lockable castors
- Weight: 13 kg



Lectern in glass design	4750 000 000
-------------------------	--------------

## Projection trolley

**Chromium-plated steel tripod with glass tray 40 cm diameter**

- Height-adjustment: 105 - 145 cm
- Lower tray 50 x 26.5 cm, height-adjustable, can be swivelled
- 5 lockable castors
- Weight: 11 kg



Projection trolley in glass design	4750 000 001
------------------------------------	--------------

# TROLLEYS FOR DATA / VIDEO PROJECTORS

## The StandMaster model

Mobile projection trolley with adjustable deposit trays.  
Stepless height adjustment 85 - 125 cm

- Can hold up to 10 kg weight (a), resp. up to 5 kg weight (b).
- Can also be used as transport trolley.
- Size of deposit trays:  
a) 42 x 35 cm, b) 36 x 24 cm
- Colour of frame (RAL 7021) dark grey.  
colour of deposit surface (RAL 7031) light grey.

**The StandMaster model** **6375 000 000**

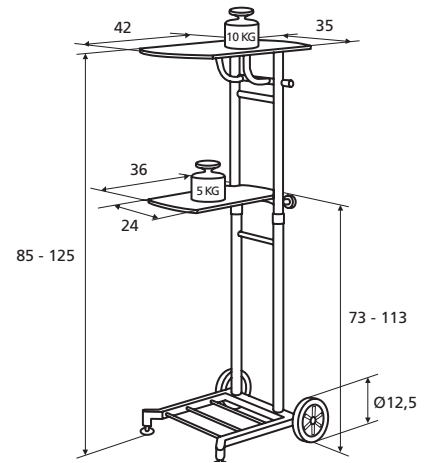

## The Gigant model

Sturdy and safe projection table with two trays.

- Can hold up to 25 kg weight (a), resp. up to 15 kg weight (b).
- Size of trays:  
a) 40 x 40 cm, b) 40 x 40 cm
- Height: 115 cm
- Colour of frame (RAL 7021) dark grey.  
colour of deposit surface (RAL 7031) light grey.

**The Gigant model** **5661 000 000**

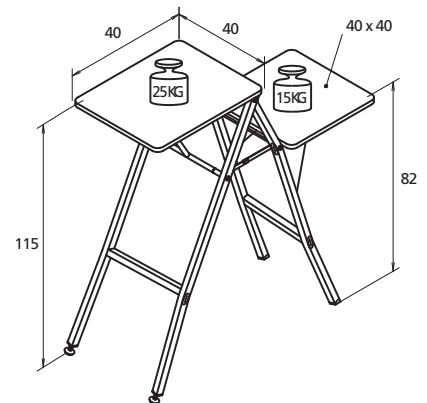

## The Solo 9000 model

Projection trolley with tiltable rimmed tray,  
40 x 50 cm.

- Can hold up to 20 kg weight
- Height: 85 - 125 cm
- Colour of frame (RAL 7021) dark grey.  
colour of deposit surface (RAL 7031) light grey.

**The Solo 9000 model** **5665 000 000**

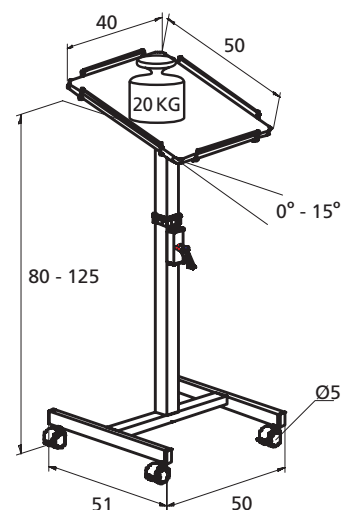

# PROJECTION WALLS – PROJECTION BOARDS

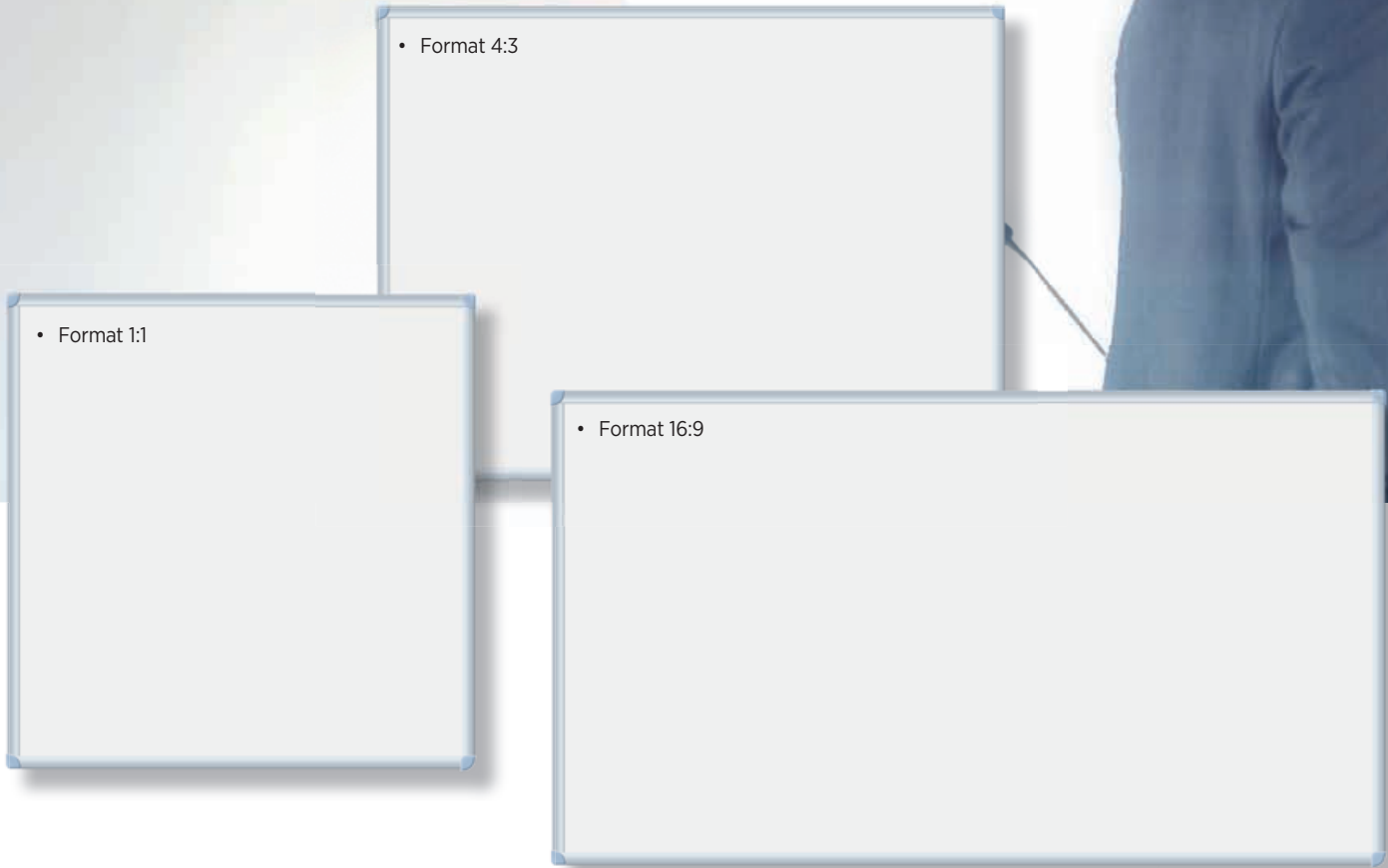

• Format 4:3

• Format 1:1

• Format 16:9

## Projection wall for wall mounting

- With frame of anodized aluminium
- Solid projection surface with special coating
- Non-magnetic
- Not suitable for writing on
- Long life
- Supplied with mounting material

### Tiltable models

Format 150 x 200 cm	4542 000 000
Format 200 x 200 cm	4542 000 001
Format 180 x 240 cm	4542 000 002
Format 115 x 200 cm	4542 000 008
Format 138 x 240 cm	4542 000 009

### Non-tiltable models

Format 150 x 200 cm	4542 000 003
Format 200 x 200 cm	4542 000 004
Format 180 x 240 cm	4542 000 005
Format 115 x 200 cm	4542 000 006
Format 138 x 240 cm	4542 000 007

## Projection board for pylon systems

- For mounting on Kindermann pylon systems
- With frame of anodized aluminium
- Solid projection surface with special coating
- Magnetic surface
- Can be dry-wiped
- Long life

### Non-tiltable models

Format 163.8 x 120 cm	4523 000 000
Format 217.1 x 120 cm	4523 000 001



# WHITEBOARDS

- For whiteboard markers
- Can be dry-wiped
- Magnetic surface
- Integrated pen tray
- Frame of anodized aluminium
- Galvanized metal back wall



## Whiteboards B-Line

- Enamelled steel surface, white
- 25 years warranty for enamelled surface

Format 90 x 120 cm	4540 000 101
Format 100 x 150 cm	4540 000 102
Format 90 x 180 cm	4540 000 103
Format 120 x 180 cm	4540 000 104
Format 100 x 200 cm	4540 000 105
Format 120 x 220 cm	4540 000 106

## Whiteboards S-Line

- Varnished surface, white

Format 90 x 120 cm	4640 000 101
Format 100 x 150 cm	4640 000 102
Format 90 x 180 cm	4640 000 103
Format 120 x 180 cm	4640 000 104
Format 100 x 200 cm	4640 000 105
Format 120 x 220 cm	4640 000 106

## Accessories

Starter package	4546 000 000
-----------------	--------------

### Please note!

For whiteboard markers and other accessories see page 108/109.

# PINBOARDS

For pinning memos, posters, instructions, notices

- Sturdy metal plate
- Different surfaces available: cork or felt
- Supplied with mounting kit

Cork, 60 x 90 cm	4740 000 100
Cork, 90 x 120 cm	4740 000 101
Felt blue, 60 x 90 cm	4741 000 100
Felt blue, 90 x 120 cm	4741 000 101
Felt grey, 60 x 90 cm	4742 000 100
Felt grey, 90 x 120 cm	4742 000 101

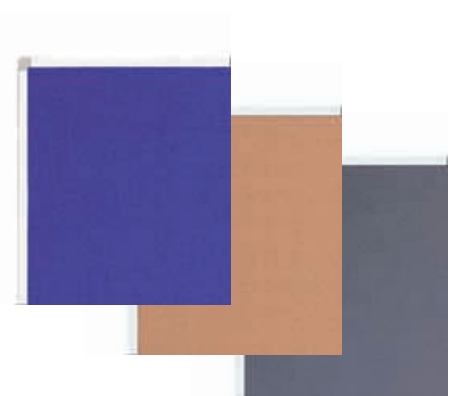

### Please note!

Other sizes, colours, and other board surfaces (e.g. blackboards) are available on demand.

## PRESENTATION BOARDS

- Light-weight, sturdy aluminium construction
- Aluminium frame with rounded corners
- Can be used on both sides
- Overall height 198 cm
- With floor gliders
- 4 castors, 2 of them lockable (optional)

Felt, light-blue, 150 x 120 cm	4530 000 100
Half linen, beige, 150 x 120 cm	4530 000 101
In carton, grey 150 x 120 cm	4530 000 102
Felt, light-blue, foldable, 2 x 75 x 120 cm	4532 000 100
Half linen, beige, foldable, 2 x 75 x 120 cm	4532 000 101
4 castors, 2 lockable	4530 000 200

## FLIPCHART

- Textile pin board, grey
- Magnetic writing board, white
- Universal holder for paper pads
- 4 lockable castors
- Board dimensions ca. 108 x 78 cm
- Overall height ca. 190 cm

Flipchart	4533 000 100
-----------	--------------



## ROTATING BOARD

- Made of white enamelled steel
- Can be swivelled and used on both sides
- Overall height ca. 195 cm
- Aluminium frame RAL 7035, light grey
- Integrated pen tray
- 4 castors, 2 of them lockable
- Base made of square steel bar 50 x 50 mm (vertical elements 50 x 25 mm)
- Format 150 x 120 cm



Rotating board

4643 000 101

## ACCESSORIES

### Presentation box

Ultra-light plastic case with 1,140 parts.  
Presentations cards, stickers and board markers.

**Contents:**

- 480 stickers, 4 colours of 120 each
- 150 presentation cards, square
- 150 presentation cards, ø 100 mm
- 150 presentation cards, ø 140 mm
- each 100 pins - blue and red
- 10 board and flipchart markers, 3 in black, 3 in red, 2 in blue and 2 in green
- 1 plastic case, blue
- 1 pin holder



**Presentation box**

**6932 000 001**

### Trolley for paper roll

Trolley for depositing charts.  
Width 1.2 m, height 95 cm, ø 20 cm,  
varnished, RAL 7035, light grey,  
with 4 castors, 2 of them lockable



**Trolley for paper roll**

**4531 000 100**

### Starter package

Complete assortment of accessories for use  
on writing boards.



**Starter package**

**4546 000 000**

### Magnets

53 x 18 mm, for holding up to 1 kg



**Magnets, package of 20 pcs.**

**4528 000 000**

### Board wiper, spare felt

**Board wiper**

**4547 000 000**

**Spare felt, 12 pcs.**

**4547 000 001**



### Pen holder, acryl

for 4 markers, vertical storage



**Pen holder**

**5806 000 005**

### All-inclusive presentation case

This best-selling presentation case helps you to hold professional seminars  
and trainings. Sturdy lockable aluminium case with complete assortment of  
accessories, incl. carrying strap and key.

**Contents:**

- 504 presentation cards 200 x 100 mm, square, 6 assorted colours
- 200 presentation cards D=100 mm, round, 5 assorted colours
- 150 presentation cards D=140 mm, round, 5 assorted colours
- 150 presentation cards D=190 mm, round, 5 assorted colours
- 200 presentation cards 190 x 110 mm, oval, 5 assorted colours
- 10 board and flipchart markers (6 x black, 4 x red)
- 4 jumbo markers (blue, green, red and black)
- 400 pins (each 100 pcs. in yellow, blue, green and red)
- 1 telescope pointer
- 2 glue sticks, each 20 g
- 1 paper cutter, 6 inch, 1 cutter, blade 9 mm wide
- 1 roll of adhesive tape with tape holder (25 m x 19 mm)
- 1 roll of adhesive tape (50 m x 30 mm)
- 1200 marker stickers (each 300 pcs. in yellow, blue, green and red)
- 1 pin cushion



**All-inclusive presentation case**

**6932 000 100**

**Rack**

**6932 000 101**



### Presentation paper

**Paper for presentation board, 50 sheets, white**

**4529 000 000**

**Paper for presentation board, 50 sheets, brown**

**4529 000 001**

**Paper for presentation board, 100 sheets, brown**

**4529 000 002**

### Board / flipchart markers

Pup-up box with 4 markers.  
Markers do not dry up, even if left open  
for days.



**Board marker set, 4 pcs., wedge tip**

**5806 000 002**

**Board marker set, 4 pcs., ball-point tip**

**5806 000 001**

**Flipchart marker set, 4 pcs., wedge tip**

**5806 000 003**

**Flipchart marker set XL, 4 pcs., ball-point tip**

**5806 000 004**

### Pin needles

**Pin needles, box of 200 pcs. assorted**

**4529 000 003**

**Pin needles, type 9012 yellow, 100 pcs.**

**4529 000 004**

**Pin needles, type 9012 blue, 100 pcs.**

**4529 000 005**

**Pin needles, type 9012 green, 100 pcs.**

**4529 000 006**

**Pin needles, type 9012 red, 100 pcs.**

**4529 000 007**

### Marking flags

**Marking flags, 20 pcs. assorted**

**4529 000 008**

### Flipchart pad

**Flipchart pad, 20 sheet, 5-pack**

**6917 000 100**

Other accessories on demand!

## Laser pointers

Make a point! These three inexpensive laser pointers support your presentations. A clearly visible dot marks details of the projection.

The laser pointers belong to safety class 2.

The model No. 6960 000 002 is equipped with 2 AAA batteries.

The models No. 6960 000 000 and 6960 000 001 are equipped with 3 batteries LR41.



Laser pointer PDA	6960 000 000
Laser pointer with extendable pointer	6960 000 001
Laser pointer, 0.049 kg	6960 000 002

## Green laser pointer

This innovative laser pointer is much brighter than any model with a red dot. You can be sure, the green dot will attract the attention of each member of your audience.

Especially useful for sunlit rooms or auditoriums.

Safety class 2, supplied with two 1.5 V AAA batteries.

- Range up to ca. 200 m
- Wave length 532 nm
- Dim.: 15.5 cm long, 1.4 cm wide
- Weight: ca. 0.074 kg, incl. batteries



Green laser pointer, black/silver	6960 000 030
Green laser pointer, black/gold	6960 000 031

## Remote controls for computer presentations

When using these remote controls you need not stand next to your notebook, and you need not ask anyone for assistance either. The radio remote allows you to move freely in the conference room. The "plug & play"

installation is really easy. The radio remote control includes all necessary functions.

- Green laser pointer, up to 10 x brighter than a model with a red dot
- Mouse function
- "Click trigger" for forefinger (left mouse button)
- Page up/down
- 4 freely configurable buttons (via software)
- Automatic adjustment of radio channel (64000 channels possible)

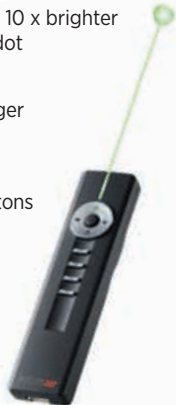

- Mouse function
- "Click trigger" for forefinger (left mouse button)
- Page up/down
- Blanking
- Laser pointer



- Mouse function
- Page up/down
- White/black monitor
- Alt + Tab (switching between applications)
- Laser pointer



Remote Point Jade	7462 000 003	Global Presenter RF	7462 000 002	WirelessP resenter	7462 000 001
-------------------	--------------	---------------------	--------------	--------------------	--------------

## Technical data

Model	Remote Point Jade	Global Presenter RF	WirelessP resenter
Range	up to 50 m	up to 30 m	up to 15 m
Frequency	2.4 Ghz	2.4 Ghz	2400 - 2483 MHz
Dimensions	160 x 38 x 27 mm	110 x 62 x 37 mm	130 x 38 x 21 mm
Weight	0.075 kg	0.140 kg	0.058 kg
Interface	USB	USB	USB
System requirements	Windows XP or higher, Mac OS X, 1 free USB port	Windows XP or higher, Mac OS X, 1 free USB port	Windows XP or higher, Mac OS X 10.1 or higher, 1 free USB port
Package includes	USB drive (receiver), batteries, manual	USB drive (receiver), batteries, manual	USB drive (receiver), batteries, manual





# THE VISULINE RAIL SYSTEM

Intelligent solutions for more flexibility in your conference room

## Rails – the basis of the system

Choose from three different aluminium rails: TOP, ECO and DUO; available in 200 and 300 cm length. Easy extension, even around the corner (with optional corner elements).

### DUO - double rails



Space-saving mounting, one element can be moved over the other. Integrated paper clamp, e.g. for technical drawings. Rails of more than 3 m length are delivered in several parts.

Length	aluminium	white (RAL 9003)
2m	5028 450 886	5028 450 885
3m	5038 450 886	5038 450 885

### TOP - universal rails



Can be used anywhere. With integrated paper clamp.

Length	aluminium	white (RAL 9003)
2m	5028 450 878	5028 450 877
3m	5038 450 878	5038 450 877

### ECO - the economy version



Without paper clamp.

Length	aluminium	white (RAL 9003)
2m	5028 450 870	5028 450 869
3m	5038 450 870	5038 450 869

### Decor strips – to cover the mounting points

Decor strip, grey	5008 450 792
Decors trip, pure white (RAL 9010)	5008 450 907
Decors trip, deep red	5008 450 893
Decors trip, sky blue	5008 450 894
Decors trip, royal blue	5008 450 895
Decors trip, deep black	5008 450 896
Metals trip, makes the decor strip magnetic	5008 450 912

### Rail end pieces



For covering the rails, with stop function for elements

Rail	end piece	aluminium	white (RAL 9003)
DUO	right	5008 450 889	5008 450 887
DUO	left	5008 450 890	5008 450 888
TOP	right	5008 450 881	5008 450 887
TOP	left	5008 450 882	5008 450 888
ECO	right	5008 450 873	5008 450 871
ECO	left	5008 450 874	5008 450 872

### Corner section



For a safe and quick mounting into 90° corners

Rail	aluminium	white (RAL 9003)
DUO	5008 450 892	5008 450 891
TOP	5008 450 892	5008 450 891
ECO	5008 450 876	5008 450 875

### Starter kit



Contains everything you need to visualize your ideas on the whiteboard.

Starterkit it	5008 450 763
---------------	--------------



## The components

### Writing boards – can be dry-wiped

White enameled magnetic surface for dry-wipe markers. To be hung up in landscape or portrait format. Including pen tray, 35 cm wide.

Size	aluminium	grey white (RAL 9002)
120 x 100 cm	5008 411 030	5008 410 047
150 x 100 cm	5008 411 031	5008 410 048
200 x 100 cm	5008 411 032	5008 410 049
250 x 100 cm	5008 411 033	5008 411 026

### Pin boards – for organization and information

Heavy-duty longlife surface (linen beige). For landscape or portrait format. Frame aluminium or grey white (RAL 9002).

Size	aluminium	grey white (RAL 9002)
120 x 100 cm	5008 411 038	5008 410 053
150 x 100 cm	5008 411 039	5008 410 092
200 x 100 cm	5008 411 040	5008 410 255

### Flipchart – height adjustable, tiltable

White enamelled magnetic surface for dry-wipe markers. Variable paper holder, for all punched paper pads; T-square for clean cutting of sheets, serves also as paper clamp.

Size	aluminium	grey white (RAL 9002)
78.5 x 107.8 cm	5008 443 203	5008 443 131

Flipchart paper pad, 5-pack 20 pages each, square	6917 000 100
---	--------------

### Flipchart clip

Transforms all VisuLine writing and pin boards into a flipchart.

Size	aluminium	grey white (RAL 9002)
72c m	5008 443 205	5008 443 120

### Mounting frame for interactive ēno boards

Steel frame 50 x 25 and 25 x 25 mm, reinforced steel mounting kit.

Mounting frame for interactive ēno board 2610, ca. 995 x 1220 mm	5008 411 706
Mounting frame for interactive ēno board 2810, ca. 1495 x 1220 mm	5008 411 707

### Screenboard II – projection and writing board – all in one

Height-adjustable and tiltable. With magnetic writing surface for wet cleaning. Allows the adding of written notes directly on the board.

Size	format	aluminium	grey white (RAL 9002)
150 x 150 cm	1:1	5008 411 057	5008 410 553
200 x 150 cm	4:3	5008 411 088	5008 410 573
200 x 125 cm	16:10	5008 411 725	5008 411 724

## Mounting kits

### VisuLine mounting kit “special” – 12 cm long

For mounting elements of other rail systems.

Mounting kit “special”, 5 cm deep, aluminium	5008 450 611
Mounting kit “special”, 5 cm deep, grey white (RAL 9002)	5008 450 267

### Projection board – with reflective surface

High-quality projection, even in sunlit rooms. Height-adjustable and tiltable up to 25° (only models with tiltable frame), for a distortion-free projection. Surface not suitable for writing.

#### With tiltable frame, folding holder and pivot frame

Frames ize	format	aluminium	grey white (RAL 9002)
150 x 150 cm	1:1	5008 410 374	5008 411 055
175 x 175 cm	1:1	5008 410 375	5008 411 056

#### Witht iltablef rame

Frames ize	format	aluminium	grey white (RAL 9002)
125 x 125 cm	1:1	5008 411 716	5008 410 056
150 x 150 cm	1:1	5008 411 044	5008 410 054
175 x 175 cm	1:1	5008 411 045	5008 410 378
200x2 00c m	1:1	5008 411 046	5008 410 379
160x12 0c m	4:3	5008 411 047	5008 410 530
180x13 5c m	4:3	5008 411 049	5008 411 717
200x15 0c m	4:3	5008 411 051	5008 410 532
240x180 c m	4:3	5008 411 053	5008 410 821
200x115 c m	16:9	5008 411 718	5008 411 714
240x13 8c m	16:9	5008 411 719	5008 411 715

#### Withoutt iltablef rame

Frames ize	format	aluminium	grey white (RAL 9002)
160 x 120 cm	4:3	5008 411 048	5008 410 601
200 x 150 cm	4:3	5008 411 052	5008 410 603
240 x 180 cm	4:3	5008 411 054	5008 410 853
150 x 87 cm	16:9	5008 411 720	5008 411 710
175 x 101 cm	16:9	5008 411 721	5008 411 711
200 x 115 cm	16:9	5008 411 722	5008 411 712
240 x 138 cm	16:9	5008 411 723	5008 411 713

## Accessories

### Magazine rack



Painted MDF plate with grooves for 8 acrylic glass shelves, with mounting kit.

Suitable for 16 DIN A4 or 8 DIN A3 formats.

Magaziner ack	5008 940 020
---------------	--------------

### Wardrobe



Oval profile with steel bracket and mounting kit. Can be easily attached to the rail. Elegant design.

Wardrobe	5008 940 073
----------	--------------

### VisuLine mounting kit for DUO rail – 12 cm long

Required for using the double rail!

Mounting kit for DUO rail, 15 cm deep, aluminium	5008 450 613
Mounting kit for DUO rail, 15 cm deep, grey white (RAL 9002)	5008 450 228

# COPYBOARDS

Make your meetings more effective

- For storing data directly on a USB memory (without PC)
- Direct connection to PC via USB cable
- For printing data (printer not included in package)
- Easy operation
- Modell M-125 also suitable for projection

## Copyboard M12 series – innovations

- Company logo possible in head or bottom line
- “Delete reminder” transports used page to the front side when the unit is switched off
- Considerably lower energy consumption
- Integrated cable guide

### Accessories

Stand with castors for 6936-xx	6936 000 003
Whiteboardmarker red, green, blue, black, for dry wiping	5806 000 001

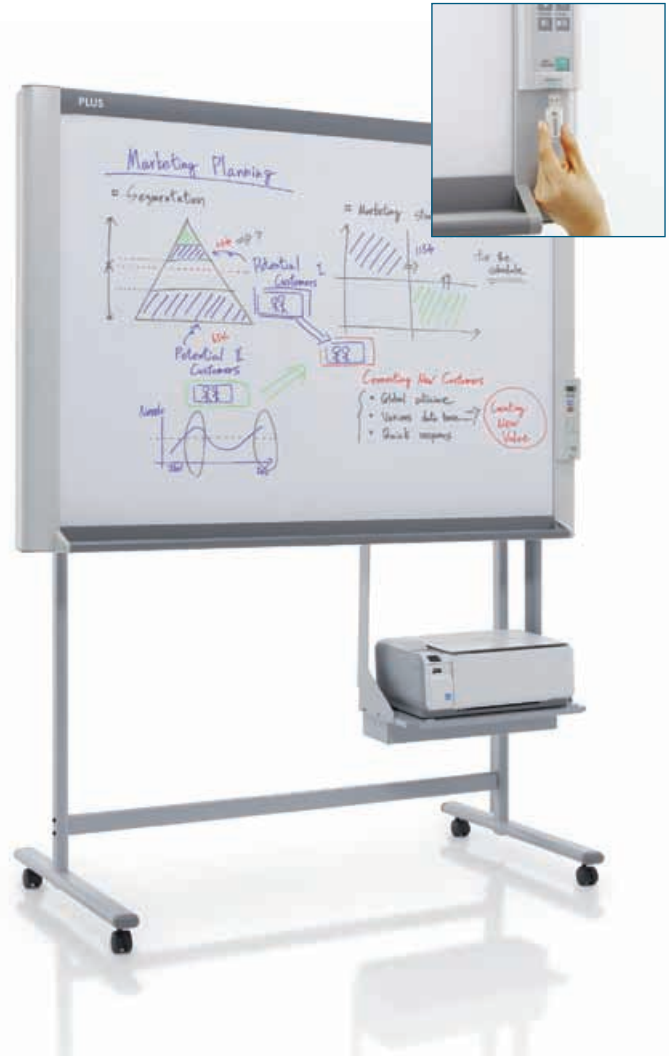

### Technical data

Model	CopyboardM -12S	CopyboardM -12W	CopyboardM -125
Ref.No .	6936 000 010	6936 000 011	6936 000 012
Installation	wall mounting or stand with castors (optional accessory)		
Outer dimensions (incl. stand)	1470 x 700 x 1970	1970 x 700 x 1970 mm	1470 x 700 x 1970 mm
Weight	41 kg	45 kg	45 kg
Board			
Scanned surface	1280 x 900 mm	1780 x 900 mm	1280 x 900 mm
Number of pages	2		4 and 1 projection surface
Scrolling method	motorized/manual		motorized
Grid size (as writing aid)	50 x 50 mm		
Reading method / resolution	CCD sensor (RGB LED)		
Printer			
Compatible printers (nots applied)	ink jet printers supporting the following printer language: (HP PCL3e/PCL 3 GUI/LIDIL, LEXMARK Z2300/2320, EPSON Proprietary Language Compatible) laser printer supporting the following printer language: (SAMSUNG Printer Language (SPL) Compatible)		
Size of paper	DIN A4 (210 x 297 mm) / Letter (8.5 x 11 ")		
Printing colour	colour or black and white		
Print density	300 dpi		
PC connection / memory			
USB inputs 1.1 or 2.0	1 x A-female (for printer), 1 x B female (for PC) control panel: 1 x A female (for USB memory)		
Memory	USB (not included)		
File format	PNG, JPEG, PDF		
Supported operating systems	Windows XP (Home Edition/Professional Edition service pack 2 or higher) / Windows Vista (32 bit)		
Operating conditions			
Power source	AC power 100-240 V, 50-60 Hz		
Power consumption	< 5 W (standby), 40 W (in operation)		
Package includes	set of markers (black, red, blue, green), eraser, power supply, USB cable (3 m), manual (printed and PDF), CD-ROM (TWIN driver), PLUS TOOLBOX (software), deposit tray for printer, wall mount		

# H30 KINDERMANN LECTERNS

These lecterns fulfill high aesthetic and functional standards. The manufacturer focusses on the integration of technology, ergonomics and classic design.

**Optionally all lecterns can also be supplied with:**

- microphone
- castors
- connection ports
- lights
- cup holder



## SPACE

Lectern of stainless steel and acrylic glass  
Space is the only lectern with two LED panels.  
Your logo or a text can be engraved in the panels or in the steel column.



## Excalibur

Designer lectern with stainless steel column and acrylic glass elements which can shine in different colours.





## PROJECTOR MOUNTS

Universal, for ceiling and wall mounting

Kindermann offers a wide range of projector mounts for the ceiling, the wall, the floor, and even for sloping ceilings. Custom-made versions are available up to 300 cm column length.



### Universal + patented

The variable spider is suitable for nearly all projectors with drill-holes on the bottom



### 2D joint

For tilting the projector in two dimensions



### 3D joint / 3D ball-point joint

For tilting, swivelling and rotating the projector in three dimensions



### Certified as to:

- Safety
- Durability
- Weight capacity
- Easy handling



### Warranty

5 years



### Mounting

Easy and quick, due to pre-assembled elements



### Choice of colour

The scratch-resistant coated projector mounts are available in two colours.



### Aluminium

Anodized





# ECO PLUS LINE

Inexpensive - for universal use

- Stepless height adjustment
- Integrated cable channel (36 x 36 mm inside)
- 2D joint for tilting the projector in 2 directions, up to  $\pm 20^\circ$  vertically and  $\pm 10^\circ$  horizontally
- Fixing points: 138 - 378 mm
- Can hold up to 15 kg
- Scratch-resistant coating
- Easy mounting, partially pre-assembled
- Supplied with screws M3 / M4 / M5 / M6 and distance elements



Kindermann Eco



Kindermann Eco Plus 60 / 100 / 150

• Integrated cable channel



• Stepless height adjustment



• Adjustable arms (patented)



• 2D joint - for tilting the unit in 2 directions



• Various distance elements for height adjustment



## Kindermann Eco Plus line - projector mounts for the ceiling

Model	Distance projector / ceiling	Colour	Ref.N o.
KindermannE co	11 cm	metallic silver, RAL 9006	5878 000 000
		white, RAL 9003	5878 000 010
Kindermann Eco Plus 60	stepless from 40 - 65 cm	metallic silver, RAL 9006	7420 000 100
		white, RAL 9003	7420 000 110
Kindermann Eco Plus 100	stepless from 60 - 105 cm	metallic silver, RAL 9006	5877 000 100
		white, RAL 9003	5877 000 110
Kindermann Eco Plus 150	stepless from 104 - 150 cm	metallic silver, RAL 9006	7440 000 100
		white, RAL 9003	7440 000 110

## COMFORT LINE

### Modern and elegant design

- Fully pre-mounted for quick installation
- Integrated cable channel
- Quick exchange of projector, e.g. for servicing
- 3D joint for tilting the projector  $\pm 20^\circ$  in all directions, rotates  $\pm 180^\circ$
- Can hold up to 20 kg
- Fixing points: 100 - 370 mm
- Cover for covering the ceiling mounting plate or the cutout in case of false ceilings (outer  $\varnothing$  142 mm)
- Crash protection in the interior of the telescopic tube
- Telescopic tube:  $\varnothing$  37 mm
- Supplied with screws M3 / M4 / M5 / M6 and distance elements
- For all Comfort mounts with height adjustment an additional cover is available on option for covering the ceiling cutout around the lower telescopic tube (Ref. No. 7429 000 003)



Kindermann Comfort 30



Kindermann Comfort 60/100, extendable

- Cover for the mounting plate or the cutout of the ceiling



- Integrated cable channel
- Integrated crash protection



- Stepless telescopic height adjustment

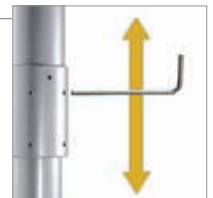

- 3D joint for tilting the projector in all directions



- Adjustable distance elements



- Quick exchange of projector



### Kindermann Comfort line - projector mounts for the ceiling

Model	Distance projector / ceiling	Colour	Ref. No.
Kindermann Comfort	12 cm	metallic silver, RAL 9006	7436 000 000
		white, RAL 9003	7436 000 010
Kindermann Comfort 30	30 cm	metallic silver, RAL 9006	7436 000 001
		white, RAL 9003	7436 000 011
Kindermann Comfort 60	stepless from 45 - 61 cm	metallic silver, RAL 9006	7437 000 000
		white, RAL 9003	7437 000 010
Kindermann Comfort 100	stepless from 65 - 100 cm	metallic silver, RAL 9006	7438 000 000
		white, RAL 9003	7438 000 010



# KINDERMANN PROFESSIONAL LINE

Meets any demand

- Fully pre-assembled (except Ref. No. 5886 000 100), for easy mounting
- Stepless telescopic height adjustment
- Can hold up to 25 kg
- Ball-point joint for tilting the projector  $\pm 20^\circ$  in directions, rotates  $\pm 180^\circ$  (Ref. No. depending on the projector dimensions!)
- External aluminium cable channel included in package (40 x 20 mm)
- Quick exchange of projector, e. g. for servicing
- Anodized aluminium column
- Variable adjustable mounting plate for sloping ceiling up to  $45^\circ$
- Supplied with screws M3 / M4 / M5 / M6 distance elements
- Custom-made versions possible on demand up to 300 cm
- Fixing points 138 - 378 mm



- Adjustable for sloping ceiling up to  $45^\circ$



all  
5886 000 100  
ge

- Supplied with cover



lings  
and  
mand,

- Supplied with cable channel



- Pro 200 supplied with safety rope



- Adjustable arms and adjustable distance elements



- Ball-point joint for tilting the projector in all directions
- Quick projector exchange



Kindermann Pro



Kindermann Pro C 60

Kindermann Pro 60-200, extendable

## Kindermann Professional line - projector mounts for the ceiling

Model	Distance projector / ceiling	Ref.N o.
KindermannP ro	13 cm	5880 000 100
Kindermann Pro C 60	stepless from 20 - 60 cm	5886 000 100
KindermannP ro60	stepless from 45 - 60 cm	5883 000 110
KindermannP ro100	stepless from 60 - 100 cm	5883 000 100
KindermannP ro150	stepless from 91 - 150 cm	5883 000 120
KindermannP ro2 00	stepless from 115 - 200 cm	5883 000 130



## KINDERMANN PREMIUM LINE Perfect design and function



- High-quality universal projector mount
- Newly developed anodized aluminium profile with fully covered interior cable channel
- Pre-assembled for quick mounting
- Stepless telescopic height adjustment
- Can hold up to 25 kg
- Ball-point joint with quick change system - for tilting the projector  $\pm 20^\circ$  in all directions, rotates  $\pm 180^\circ$
- Supplied with screws M3 / M4 / M5 / M6 and distance elements
- Custom-made versions possible on demand, up to 300 cm column length
- Fixing points 138 - 378 mm

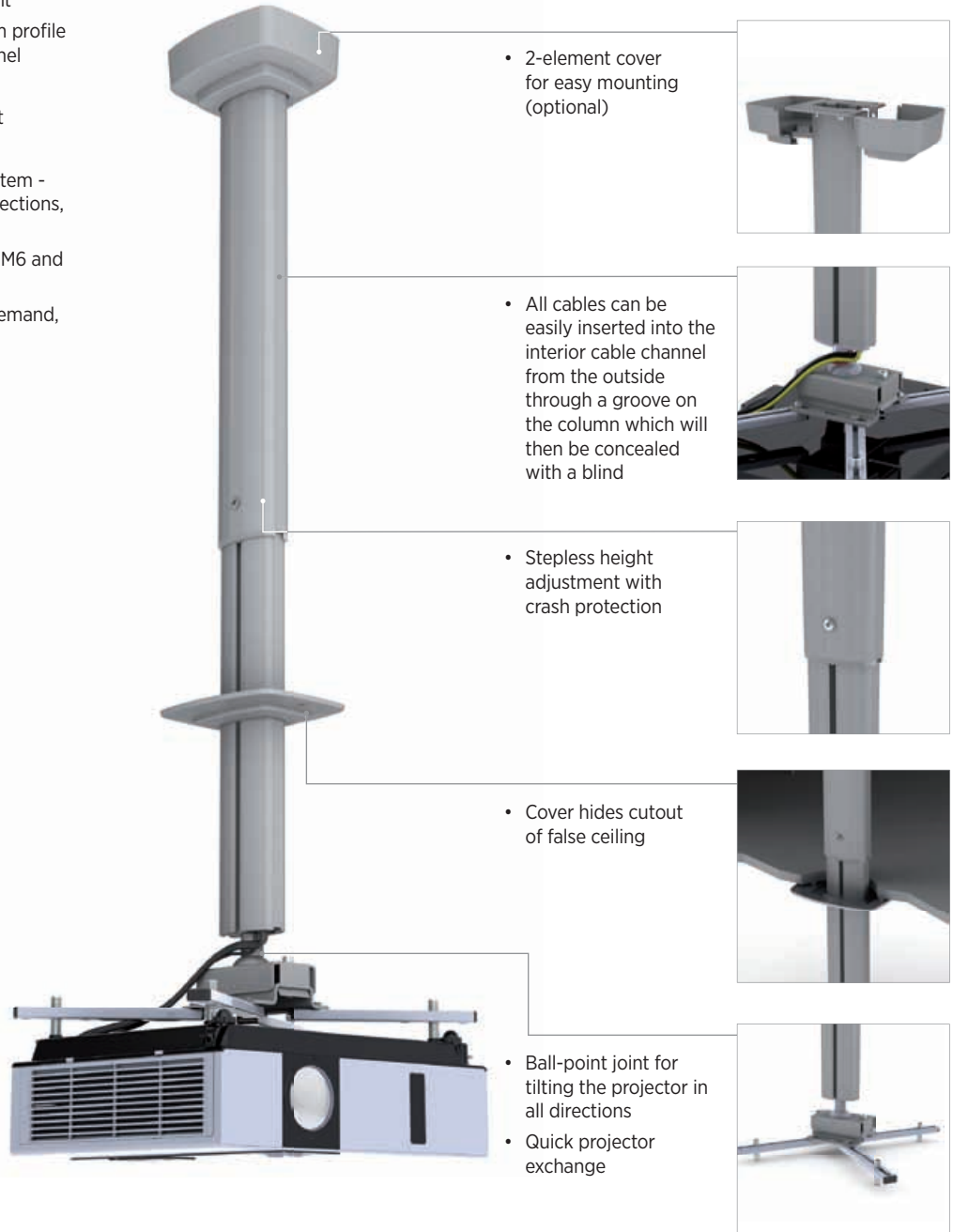

### Kindermann Premium line - projector mounts for the ceiling

Model	Distance projector / ceiling	Colour	Ref.N o.
KindermannP remium3 0	30 cm, can be shorted to up to 10 cm	anodized aluminium	7450 000 030
		white, RAL 9003	7450 000 031
KindermannP remium60	stepless from 41 - 61 cm	anodized aluminium	7450 000 060
		white, RAL 9003	7450 000 061
KindermannP remium100	stepless from 61 - 100 cm	anodized aluminium	7450 000 100
		white, RAL 9003	7450 000 101
KindermannP remium150	stepless from 86 - 150 cm	anodized aluminium	7450 000 150
		white, RAL 9003	7450 000 151
KindermannP remium2 00	stepless from 111 - 200 cm	anodized aluminium	7450 000 200
		white, RAL 9003	7450 000 201

## HOME CINEMA CT

Small, flat and inexpensive



Universal ceiling mount, ideal for home use and restaurants.

- 3D joint for tilting the projector  $\pm 12^\circ$  in all directions, rotates  $\pm 180^\circ$
- Can hold up to 10 kg
- Easy to mount, pre-assembled
- Fixing points 120 - 350 mm
- Supplied with screws M3 / M4 / M5
- Small shipping size: package only 8 x 6.5 x 21 cm



Kindermann Home Cinema CT - projector mount for the ceiling

Model	Distance projector / ceiling	Colour	Ref.N o.
HomeCinemaCT	7 cm	metallic silver, RAL 9006	7419 000 000

## KINDERMANN COMFORT TURN 60

Motorized rotating ceiling mount



The Comfort Turn 60 is a motorized ceiling mount for quickly rotating projectors. Press a button and a motor integrated in the column rotates the holder up to  $240^\circ$ . The two selectable top positions can be programmed.

The Comfort Turn 60 is the ideal solution for multi-purpose conference rooms. It is e.g. possible to make presentations on two screens on opposing walls, and only one projector will do.

- Electrically operated ceiling mount for quickly rotating a projector
- Two selectable stop positions
- Can hold up to 20 kg
- Tolerance for positioning projectors max.  $\pm 5$  mm
- Aluminium ball-point joint for tilting the projector in all directions up to  $\pm 20^\circ$ , rotates  $\pm 180^\circ$ .
- Fully pre-assembled, trouble-free mounting
- Crash protection in the interior of the telescope tube
- Supplied with power supply (5 V DC / 6 W) and set of screws for projector mounting (M3 / M4 / M5 / M6)



Ceiling mount	Colour	Distance projector / wall	Ref.N o.
ComfortTurn60	metallic silver, RAL 9006	stepless from 49 - 65 cm	7457 000 000
2-pin switch for Comfort Turn 60, Busch-Jaeger Reflex Si, in-wall			5944 000 005



## KINDERMANN COMFORT W 140

### Wall mount for projectors

- With plastic cover for concealed cable outlet
- Integrated cable channel, upright mounting of projector possible
- Quick exchange joint for easy exchange of the projector
- Can hold up to 10 kg
- 3D joint for tilting the projector  $\pm 20^\circ$  in all directions, rotates  $\pm 180^\circ$
- Fixing points: 100 - 370 mm
- Supplied with screws M3 / M4 / M5 / M6 and distance elements



Projector mount for the wall	Colour	Distance projector / wall	Ref.N o.
Kindermann Comfort W 140	metallic silver, RAL 9006	stepless from 88 - 140 cm	7439 000 100
	white, RAL 9003		7439 000 110

# KINDERMANN PRO W / PRO W100

## Wall mounts for projectors

- Quick exchange joint for easy exchange of the projector
- Custom-made versions available on demand, up to 3 column length (Pro W 100)
- Pro W 100 supplied with safety rope
- Can hold up to 25 kg
- Ball-point joint for tilting the projector  $\pm 20^\circ$  in all directions, rotates  $\pm 180^\circ$
- Fixing points: 138 - 378 mm
- Supplied with screws M3 / M4 / M5 / M6 and distance elements
- Pro W also suitable for upright mounting the projector

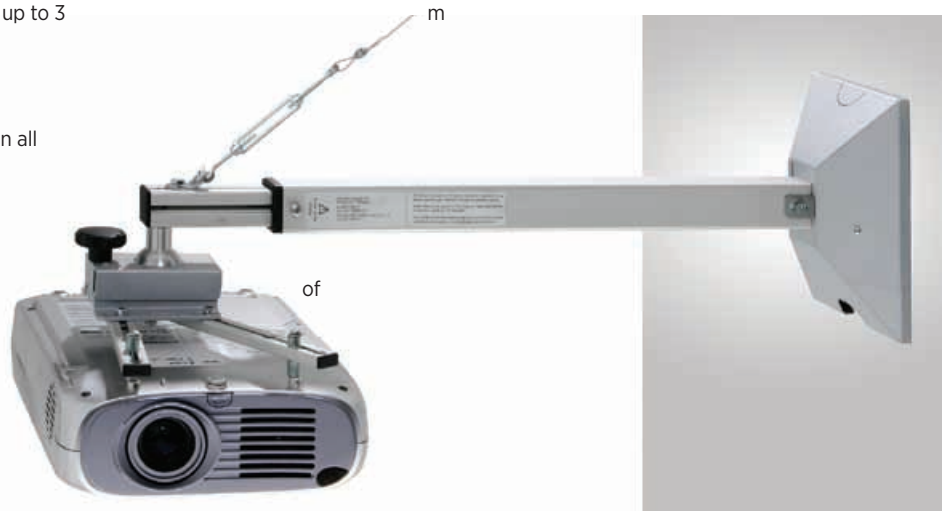

Kindermann Pro W



Projector mounts for the wall	Colour	Distance projector / wall	Ref.N o.
KindermannP roW	metallic silver, RAL 9006	stepless from 15,5 - 30,5 cm	5889 000 100
Kindermann Pro W 100	anodized aluminium, RAL 9006	stepless from 51 - 86 cm	7421 000 100

# FLIGHT FRAME

## Holder for professional data/video projectors

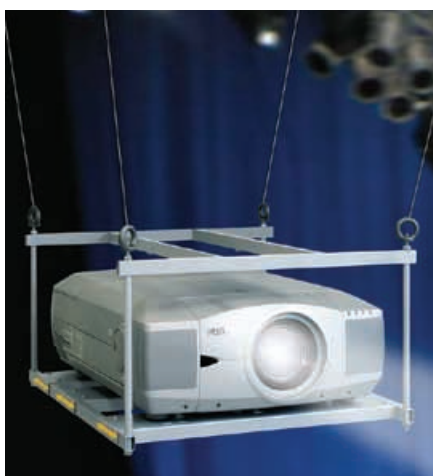

- For mounting large and heavy projectors, e. g. Sanyo XF47, in standing or hanging position
- Max. projector weight: 75 kg
- Fixing of the projector through its drill-holes at the bottom of the housing on 3 movable carrying rails (pre-made long holes suitable for many projectors)
- To be hung up at four hooks or fixed to the ceiling mount No. 6360 000 001
- Weight of Flight Frame: ca. 15 kg

Projector mounts	Colour	Dimensions	Ref.N o.
FlightF rame	metallic silver, RAL 9006	max. projector size 72 x 62 x 31 cm	6360 000 010
Ceiling mount for Flight Frame	metallic silver, RAL 9006	height adjustable 65 - 100 cm in 5 cm steps, joint for horizontal and vertical tilting $\pm 5^\circ$	6360 000 001
Holding bracket for EPSON Z series	metallic silver, RAL 9006		6360 000 020



## ANTI-THEFT PROTECTION



### Anti-theft device

- For notebooks, projectors, etc. with security lock slot
- Plastic coated steel rope
- Length 1.5 m
- Diameter 4 mm

Anti-theft device	5775 000 000
Anti-theft device, with identical key code	5775 000 001



### Two-element anti-theft device

The two-element anti-theft device effectively protects projectors which are fixed to a ceiling mount against unauthorized removal.

The system is compatible with all Kindermann ceiling mounts and can be added later.

- A high-quality "ABUS" safety rope with lock (rope 11 mm diameter) makes it impossible to disconnect the projector from the holder.
- A special safety rope (length 95 cm) additionally secures the projector holder on the ceiling.



Two-element anti-theft device	7426 000 000
-------------------------------	--------------



### Acoustic anti-theft device

Versatile and handy battery operated security alarm system with motion sensor for notebooks, projectors, flat screen display etc.

- Self-winding corrosion-free steel rope (1.2 m x 1.5 mm)
- 3-digit combination lock (1,000 combinations) with reset option
- Motion sensor activates 100 dB alarm
- LED indicates the alarm status
- Supplied with safety adapter (battery not included)

Acoustic anti-theft device	7425 000 001
----------------------------	--------------

## SAFETY AGAINST THEFT AND VANDALISM



### Sonic Shock – acoustic anti-theft device

Sonic Shock is an alarm system which is attached to projectors, displays, computers etc. with contact glue. The alarm is triggered off when severing the sensor cable, and reaches an alarm of 117 dB. With the alarm on, the battery is good for about 2 hours.

- 117 dB alarm
- Longlife battery, must be exchanged only after 4 – 5 years or after an alarm
- Exchangeable locks, also available with identical key code on demand
- Mounting: contact glue, can hold up to 211 kg/cm<sup>2</sup> on metal and most types of plastic
- Package includes: Sonic Shock, base plate, sensor cable, 2 keys, 9 V battery, contact glue, installation manual
- Size: 50 x 97 x 35 mm

SonicShock

7425 000 020



### Safety cage

The sturdy case of 1 mm thick punched metal sheets effectively protects projectors against theft and vandalism. The opening for the lens is covered by a glass pane.

- With camlock
- Can be fitted to all Kindermann ceiling mounts with height adjustment, except No. 5886 000100

	Safetycage
Ref.No .	7426 000 001
Size of housing	47 x 45 x 30 cm
Max. projector size	37 x 37 x 15 cm
Colour	RAL 9006 – scratch-free coating
Weight	8.2 kg



### Projector safe

The housing of the well-designed octagonal projector safe protects the projector against theft and vandalism in public buildings, schools, universities and entrance halls.

The housing which is made of punched metal sheets and completely closed by a glass pane, does not need any ventilation. It is secured by a high-quality camlock (Burg), an additional padlock can be installed. The housing can be easily handled and mounted.



- Can be fitted to all Kindermann ceiling mounts with height adjustment, except No. 5886 000100

	Projector safe	Projector safeXL	Projector safe XL Wide
Ref.No .	7426 000 002	7426 000 003	7426 000 004
Size of housing	45 x 44.5 x 29.5 cm	60 x 44.5 x 29.5 cm	45 x 62.5 x 29.5 cm
Max. projector size	40 x 40 x 16 cm	55 x 40 x 16 cm	40 x 60 x 17 cm
Colour	RAL 9003 – scratch-free coating		
Weight	8.5 kg	9.5 kg	13 kg

## Accessories for projector mounts

Illustration	Item	Specification	Ref.N o.
	Carrying ray	<ul style="list-style-type: none"> <li>For projectors, players etc.</li> <li>Surface 32 x 32 cm</li> <li>Max. height 16 cm</li> <li>Suitable for Eco and Pro mounts</li> <li>Can be mounted directly on the ceiling</li> </ul>	5879 000 000
	Holding bracket	Set of 2 clamps for fixing the ceiling mount on tube-shaped supports (truss) with max. 30 - 70 mm diameter	5873 000 000
	Tilting joint	For fixing mounts of the Eco line, Comfort line and Premium line on sloping ceilings. Max. tilting 45°	7450 000 013

## Accessories for Professional line

Illustration	Item	Specification	Ref.N o.
	Cover plate	For covering the mounting plate of the height-adjustable Pro mounts <ul style="list-style-type: none"> <li>2 parts, with perforated cable outlet</li> </ul>	7429 000 001
	Set of longer spider arms for large projectors	e.g. for Sanyo XP series, Mitsubishi KD 6600 etc., max. distance of the drill-holes on the projector: 493 mm	5883 000 001
	Adapter plate for EPSON Z series	For fixing on mounts of the Professional line (5883-xxx) and Premium line (7450-xxx)	5883 000 002

## Accessories for Premium line

Illustration	Item	Specification	Ref.N o.
	2-element cover	<ul style="list-style-type: none"> <li>white, RAL 9003</li> <li>15 x 13 x 6 cm</li> </ul>	7450 000 010

## Accessories for Comfort line

Illustration	Item	Specification	Ref.N o.
	Cover	For covering the cutout of the ceiling around the lower telescopic tube. For all Comfort mounts with height adjustment. White, RAL 9003	7429 000 003



## KINDERMANN PROJECTION MODULE

Double mirror module with universal mount for integration in conference furniture

The module allows the concealed installation of a projector in a piece of furniture, e.g. a conference table. Thus the appearance of a conference room is not marred by visible technology.

A finger tip on the mirror flap is sufficient, a pneumatic spring opens the module, and the projection can begin. The image is projected on the screen via two high-quality surface mirrors.

For the optimal integration in the furniture, the projection module is available in two versions:

With a powder coated metal casing, silver, RAL 9006, or with an anodized aluminium mirror flap and frame for an installation level with the desktop, to create an especially elegant design.

Technical data	
Dimensions	335 x 335 mm
Installation depth - measured from the top side of the desk	Projector height + 65 mm
Desktop cutout	310 x 310 mm; for the version "Elegance" a groove must be milled into the desktop
Thickness of desktop	25 - 30 mm, to be adapted if necessary (with 7030 000 000)
Projector weight	Up to 7 kg; projectors longer than 35 cm need an additional support
Up/down ratio projector	For distortion free projection => 9:1
Projection ratio projector	min. 1.5 Due to the double mirror the projection distance is prolonged by approx. 40 cm measured from the frame, i. e. the mirror must be positioned closer to the screen than with normal desktop projection.

Kindermann projection module Standard, powder coated, RAL 9006	7030 000 000
Kindermann projection module Elegance, anodized aluminium	7030 000 001
Projector switch off electronics For automatic on and off of the projector when opening or closing the mirror flap; for projectors with standard RS 232 protocol (KINDERMANN, EPSON, SANYO, MITSUBISHI)	7030 000 015

Projection position



Installation level with desktop



Projector is inserted horizontally







## KINDERMANN CEILING LIFTS

Ceiling lifts allow you to install your data/video projector in a false ceiling of a conference room. If not in use, the projector is hidden behind the panelling of the ceiling and thus protected against theft. Press the button and the projector is lowered and ready for use.

The upward position of the projector as well as its position in the projection mode is fixed and permanently stored via a programming unit when the ceiling lift is installed. A safety switch stops the lift on its way down when hitting an obstacle.

The lift can be operated by up/down switch, remote or media control, or via the bus system of a building.



**The product quality and safety of the Pro and Compact range is certified by LGA (Bavaria):**

- Durability proved by longterm testing
- Endurance test with double load
- EMV test (electro-magnetic interferences)
- Corrosion resistance



# KINDERMANN CEILING LIFT COMPACT 80/120

Compact ceiling lift with minimum installation height

The Kindermann ceiling lift Compact is extremely flat. For projectors of not more than 6.5 cm, e.g., a false ceiling of 12 cm (Compact 80) or 14 cm (Compact 120) is sufficient.

The Compact lift is easy to mount, and its mounting frame (Ref. No. 7466 000 010) fits into false ceilings with standardized ceiling elements of 60 x 60 cm.

An integrated safety switch stops the lift on its way down when hitting an obstacle.

A power supply for the projector is pre-installed. A spiral cable guide guarantees safe power and data supply. There is a 4-pin connection control for mains (230 V) and up and down control.

The position of the projector can be easily fixed via a separate programming unit (Ref. No. 7466 000 100/ -101).

- Lifting range up to 120 cm
- Max projector weight 20 kg
- Super flat universal projector holder
- Installation height > 12 cm
- Sturdy construction
- Easy mounting

Ceiling lift Compact 80





Ceiling lift Compact 120



## Technical data

	Ceiling lift Compact 80	Ceiling lift Compact 120
Ref.No .	7466 000 000	7466 000 001
Installation height	6 cm + projector height, min. 12 cm	8 cm + projector height, min. 14 cm
Projector mounting	universal projector mount (fixing points between 75 - 370 mm)	
Lifting range	up to 80 cm	up to 120 cm
Weight of lifts	24 kg (without projector)	26 kg (without projector)
Max. projector size	47 x 56 cm	
Max. projector weight	20 kg	
Power consumption	220 W	
Voltage	230 V, 50 Hz	
Connection	4-pin (up/down/PE/N)	
Required ceiling space	69 x 73 cm	
Cutout of ceiling	60 x 50 cm	
Ceiling plate	optional accessory	
Colour	metallic silver, coated (RAL 9006)	

## Accessories for ceiling lifts Compact 80/120 (see page 72-73 for more accessories)

Illustration	Item	Specification	Ref.No.
	Ceiling plate Standard	550 x 650 mm for covering the ceiling, white (RAL 9003)	7466 000 011
	Ceiling plate with T profile	For invisible mounting, integration of the ceiling cutout (500 x 600 mm) in the lift (RAL 9003)	7466 000 010
	Metal ceiling plate	For visible mounting of the lift on the ceiling, 4 parts, height ca. 35 cm, white (RAL 9003)	7466 000 020

# CEILING LIFTS PRO 120/250

## Professional low-noise ceiling lifts

The ceiling lift Pro is easy to mount and requires a cutout of the ceiling of minimum 74 x 54 cm.

A spiral cable guide protects the mains cable as well as the control and data cables when the lift is in operation. The power supply (230 V) for the motor control up/down is via a 5-pin socket.

The upward position of the projector as well as its position in the projection mode is once fixed via a separate programming unit (No. 7466 000 100/7466 000 101 for Pro 120 resp. No. 7466 000 105 for Pro 250).

This can also be done when the lift is in its upward position.

- Max. projector weight 30 kg
- Super flat universal projector holder, tiltable
- Spiral cable guide for cable protection
- Safety switches, e.g. for switching off the power when the projector is lifted
- Model with 250 cm lifting range and more supplied with SMI motor: for programming a third or fourth stop position, e.g. for servicing
- Custom-made versions up to 340 cm lifting range on demand



Ceiling lift Pro 120



Ceiling lift Pro 250



### Technical data

	Ceiling lift Pro 120	Ceiling lift Pro 250
Ref. No.	7465 000 050	7465 000 053
Installation height	230 mm + projector height	335 mm + projector height
Projector mounting	with screws (M3/M4/M5/M6) on projector bottom, fixing points between 138 - 378 mm	
Lifting range	up to 120 cm	up to 250 cm
Weight of lift	ca. 32 kg (without projector)	38 kg (without projector)
Max. projector size	45 x 65 x 20 cm	
Max. projector weight	30 kg	
Voltage	230 V / 50 Hz	
Power consumption	220 W	200 W
Connection	4-pin (up/down/PE/N)	5-pin (up/down/L/N/PE) for SMI motor
Required ceiling space	69 x 49 cm	
Cutout of ceiling	74 x 54 cm	
Ceiling plate	adjustable steel plate	
Colour	metallic silver, coated (RAL 9006)	

### Accessories for ceiling lifts Pro 120/250 (see page 72-73 for more accessories)

Illustration	Item	Specification	Ref. No.
	T profile	For holding the cutout panelling. Note: size of cutout changes to 752 x 552 mm	7465 000 020



# CEILING LIFT PRO XL

## For large projectors

The ceiling lift Pro XL is a professional lift for large projectors, e. g. the SANYO model PLC XF47.

A spiral cable guide protects the mains cable as well as the control and data cables when the lift is in operation. The power supply (230 V) for the motor control up/down is via a 5-pin socket.

The upward position of the projector as well as its position in the projection mode is once fixed via a separate programming unit (No. 7466 000 105). This can also be done when the lift is in its upward position.

- Max. projector weight: 50 kg
- Spiral cable guide for cable protection; we recommend to have all projector cables inserted during the installation of the unit
- Maintenance-free transmission motor
- Safety belt - for additional crash protection
- Safety switches, e.g. for switching off the power when the projector is lifted
- Custom-made versions up to 340 cm lifting range on demand



Ceiling lift Pro XL



### Technical data

	Ceiling lift Pro XL 120	Ceiling lift Pro XL 250
Lifting range	120 cm	250 cm
Ref.No .	7465 000 100	7465 000 103
Installation height	min. 56 cm, with ceiling plate	
Projector mounting	Projector in upright position (Keystone correction via lens shift), fixing on 3 adjustable carrying arms via the drill-holes on the projector bottom	
Weight of lifts	ca. 50 kg (without projector)	
Max. projector size	75 x 62 x 33 cm	
Max. projector weight	max. 50 kg	
Voltage	230 V / 50 Hz	
Power consumption	330 W	
Connection	5-pin (up/down /L/N/PE) for SMI motor	
Required ceiling space	69 x 49 cm	
Cutout of ceiling	98 x 77.6 cm	
Ceiling plate	Steel plate with T profile, coated white (RAL 9003) – Ref. No. 7465 000 110 (accessory)	
Colour	Metallic silver, coated (RAL 9006)	

### Accessories for ceiling lift Pro XL (see page 72-73 for more accessories)

Illustration	Item	Specification	Ref.N o.
	Ceiling plate with T profile	Integration of the ceiling cutout (95.6 x 75.2 cm), RAL 9003	7465 000 110
	Bracket for EPSON Z series	Metallic silver, RAL 9006	6360 000 020



Ready in ca. 30 seconds!

## CEILING MIRROR FOR DATA/VIDEO PROJECTORS

Mirror projection system for false ceilings

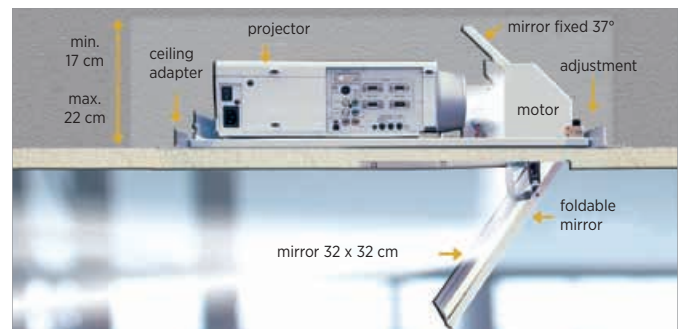
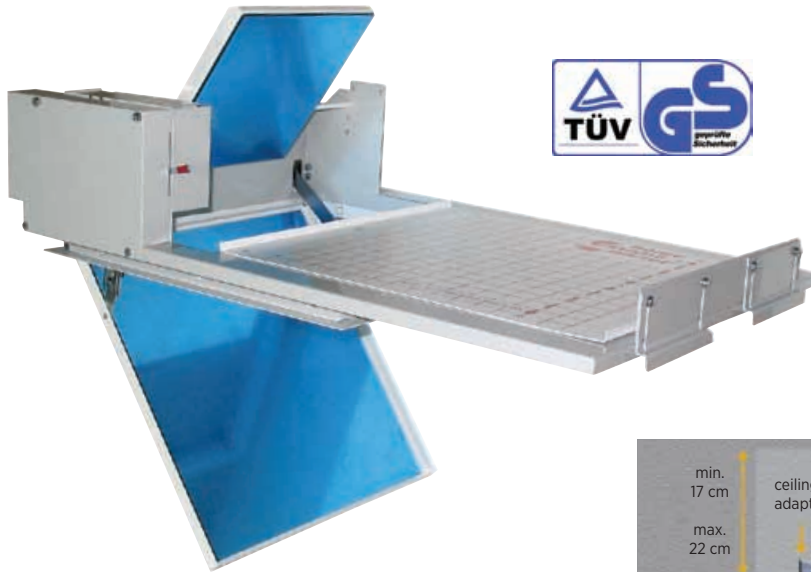

The ceiling mirror makes it possible to install the projector in the space between the room ceiling and the false ceiling. Thus the technology remains invisible. Moreover, the projector is effectively protected against dust, smoke and theft.

Press the button and the foldable mirror opens quietly, the projector is ready for use and projects the image on the screen via two high-quality mirrors.

The projection distance grows about 40 - 50 cm, i. e. either the mirror must get closer to the screen or the projector lens must be able to compensate for the bigger projection distance, the picture size remaining the same.

There is an additional advantage: the fan noise is sharply reduced while the projector is in use. The mirror is suitable for standard projectors with LCD or DLP technology.

### Technical data

Kindermann ceiling mirror	
Ref.No .	7467 000 000
Mounting space (depending on the adjustment of the upper mirror)	min. 17 - 22 cm
Max. height of the projection beam	10 cm
Max. length of the projector	42 cm
Projection ratio	min. 1.5:1
Up/down ratio	min. 9:1
Distance to screen	Projection distance acc. to manufacturer -50 cm
Overall dim. of the complete mirror system	63 x 40 cm
Overall dim. of the foldable mirror	33.5 x 33.5 cm
Extension of the foldable mirror	max. 27 cm
Control	see accessories
Weight	8.2 kg
Voltage	230 VAC / 50 Hz
Power consumption	10 W



# CEILING MIRROR PRO

## The professional solution

- Harmonious optical design due to concealed installation of the projector, and integration of the ceiling cutout into the mirror flap
- Servicing of the projector through opening in ceiling; the projector is mounted on a tray which can be swivelled out for maintenance.
- Normally no separate servicing flap is required
- Well-designed construction, even as to details: professional adjustment of frame, mirror flap and projector for optimal images
- Small installation height
- Motorized mirror flap, to be operated via switch up/down, IR resp. radio or media control
- In case of malfunctions, e.g. power cutdown, the mirror flap can be opened manually
- Patented system (DBGM)

### Easy mounting

The projector is mounted on the universal Kindermann projector holder which is fixed on a tray in the frame of the ceiling mirror. Therefore the projector can be shifted horizontally and vertically. This makes adjusting and servicing it possible without maintenance flap.

The upper mirror is adjustable in 3 positions. The mirror flap can be covered with the material of the ceiling cutout.

### Several mounting options:

With threaded bolts (optional) that reach into the real ceiling, via mounting brackets on the carrying parts of the ceiling constructions, or via fixing adapters on the carrying frames of standard false ceilings with grids 60 x 60 cm resp. 62.5 x 62.5 cm.







### Technical data



Kindermann ceiling mirror PRO	
Ref.No .	7469 000 000
Overall dimensions	535 mm x 630 mm x 180 mm
Colour	white RAL 9003
Required mounting space between standard ceiling and false ceiling	115 mm + projector height, min. 200 mm
Ceiling cutout	507 x 525 x 27 mm (with T profile for ceiling cutout)
Mounting	Installation depth min. 250 mm, if the frame is to be mounted in the ceiling cutout
Weight	18 kg
Thickness of ceiling	max. 22 mm
Mirror	Surface mirror of glass, reflexion min. 95%
Swivelling range of mirror flap	0° up to 60°, for servicing up to 85°
Motor	12 VDC, 20 W
Power supply	230 VAC, 9 VDC/2 A
Power consumption	15 W
Control	Low voltage input for switch, radio or remote, or media control
Operating time	25 seconds for opening, 35 seconds for closing
Requirements for projector installation	
Projector	max. dim.: 490 x 500 mm, max. weight: 15 kg, lens must be in the centre
Up/down ratio	min. 9:1 for a distortion-free projection
Distance ratio	min. 1.5 When the lens position is on min. ratio 2.0, a 10 % lower, distortion-free projection is possible
Distance mirror front edge to screen	Projection distance acc. to manufacturer minus 70 cm

## Accessories for Kindermann ceiling lifts and ceiling mirror Pro







### Kindermann ceiling lift Pro 120 and Compact 80/120

Illustration	Item	Specification	Ref. No.
	Programming unit Standard	With 4-pin connection cable, for programming the stop positions, reusable	7466 000 100
	Programming unit Electronic	With 4-pin connection cable, for a more convenient programming of the stop positions, reusable	7466 000 101
	Safety switch for ceiling lift Compact	Mechanical switch 230 VAC, 10 A, e. g. for cutting off the projector from power when ceiling lift is lifted, stop position adjustable	7466 000 015
	Joint for ceiling lift Compact	With long spider arms. Required, e.g., for installing Sanyo PLC XP 100/200 or Mitsubishi XL 6600	7466 000 012

### Kindermann ceiling lift Pro 250 and Pro XL with SMI motor

Illustration	Item	Specification	Ref. No.
	Programming unit Standard for SMI motor	With 5-pin connection cable, for programming the stop positions, reusable	7466 000 105
	Programming unit for 4 positions with SMI motor (up, 2 projection positions, lower servicing position)	Consisting of: SMI control unit, SMI interface, programming unit, power supply 24 VDC, 1 A	7465 000 120

### Accessories for all ceiling lifts and ceiling mirror Pro

Illustration	Item	Specification	Ref. No.
	Up/down switch	10 A / 250 VAC, 2-pin, on-wall mounting, Busch-Jaeger Reflex Si, white	5944 000 002
	Key switch	2-pin, on-wall mounting	5944 000 001
	Radio remote control for ceiling lifts and screens	<ul style="list-style-type: none"> <li>Radio frequency: 433 MHz</li> <li>Radio or IR receiver: One receiver in a room can be controlled together or independently by up to 20 senders (depending on programming)</li> </ul>	5699 000 020
	IR remote control for ceiling lifts and screens	Incl. on-wall receiver, touch button (with cable) and mobile sender	5699 000 021
	Motor control unit with relay inputs for ceiling lifts and screens		5699 000 022
	Electronic on/off device for projectors	<p>Switches projectors on or off automatically via RS232 standard control*, for projectors by Kindermann, EPSON, SANYO, Mitsubishi (on/off/status). With power supply 5 V DC. Control via safety switch in ceiling lifts Pro and Compact (optional accessory No. 7466 000 015).</p> <p>* If in doubt, please ask us as to compatibility.</p>	7465 000 016

## Accessories for ceiling mirror Pro

Illustration	Item	Specification	Ref. No.
	<b>Control board for ceiling mirror Pro</b>	For using radio remote control No. 5699 000 020 or IR remote control No. 5699 000 021	<b>7469 000 010</b>
	<b>Set of threaded bolts</b>	For invisible mounting of the mirror on the real ceiling, e. g. if the false ceiling is not strong enough.  Package includes: 4 threaded bolts M8, length 100 cm	<b>7467 000 014</b>

## Accessories for ceiling mirror Ref. No. 7467 000 000

Illustration	Item	Specification	Ref. No.
	<b>Mounting frame with maintenance opening</b>	For integrating the ceiling mirror into false ceilings, e. g. plaster board ceilings, acoustic ceilings or as maintenance opening in the false ceiling.  Package includes: Mounting frame (white) Outer dim. 62 x 62 cm Required cutout of ceiling: 60.5 x 60.5 cm	<b>7467 000 015</b>
	<b>Bracket 63 cm</b>	For integrating the ceiling mirror into false ceilings with grid size 63 cm	<b>7467 000 013</b>
	<b>Set of threaded bolts</b>	For invisible mounting of the mirror on the real ceiling, e. g. if the false ceiling is not strong enough.  Package includes: 4 threaded bolts M8, length 100 cm	<b>7467 000 014</b>
	<b>Touch button</b>	Busch-Jaeger, Reflex Si, in-wall	<b>7467 000 011</b>
	<b>Radio remote control</b>	1-channel, consisting of wall switch (= receiver) and mobile sender	<b>7467 000 012</b>
	<b>IR remote control</b>	1-channel, incl. wall switch (= receiver) and mobile sender	<b>5699 000 016</b>
	<b>Status sensor for media control</b>	Reports the status of the mirror flap (open or closed) to the media control device. Connection to media control via 1 or 2 I/O inputs (for max. 40 V/2A)	<b>7467 000 020</b>
	<b>Electronic on/off device for Kindermann ceiling mirror</b>	Switches projectors on or off automatically via RS232 standard control*, for projectors by Kindermann, EPSON, SANYO, Mitsubishi (on/off/status). Includes status sensor No. 7467 000 020*  * If in doubt, please ask us as to compatibility.	<b>7467 000 021</b>



## THE UNIVERSAL MAXXMOUNT SYSTEM

Modular system for stationary or mobile use

Numerous applications make the MaxxMount system indispensable for the stationary or mobile use of flat screen displays, interactive writing boards or video conference systems in modern, elegant rooms.

- Motorized height adjustment
- For mobile use or for wall mounting
- Complete range of accessories
- Concealed wiring

For conference or lecture rooms, digital signage, point of sale, video conference



Interactive whiteboard, mobile

- MaxxMount trolley
- Universal holder for whiteboards
- Folding arm for short throw projector
- Tray for laptop



Interactive whiteboard,  
stationary

- MaxxMount holder for wall mounting
- Universal holder for whiteboards
- Arm for ultra short throw projector
- Tray for laptop



### Mobile presentation

- MaxxMount trolley
- Universal holder for flat screen display
- Tray for compact PC
- Back wall covering
- Holder for audio system
- Tray for keyboard



### Video conference system

- MaxxMount trolley Twin with MultiMedia compartment
- Universal holder Twin for 2 flat screen displays
- Tray for video camera

## THE MAXXMOUNT COMPONENTS

Choose from the following components for your configuration



### MaxxMount column for wall mounting

Profile of anodized aluminium, for permanent wall mounting; with motorized height adjustment up to 50 cm; Wieland mains connection, connection port with 230V mains socket, VGA, AUDIO, LAN, concealed wiring

Dimensions: ca. 28.5 x 14 x 199 cm, weight: ca. 40 kg

**MaxxMount column for wall mounting**

**7514 000 100**



### MaxxMount trolley

Profile of anodized aluminium with trolley of powder-coated steel RAL 7016; with motorized stepless height adjustment from 197 - 247 cm; Wieland mains connection, integrated cable guide, connection port with 230 V mains socket, VGA, AUDIO, LAN, 4 castors, 2 of them lockable, d=12.5 cm

Dimensions: ca. 131 x 52 x 197 cm, weight: ca. 90 kg

**MaxxMount trolley**

**7514 000 200**



### MaxxMount trolley Twin with MultiMedia compartment

For 2 displays max. 52"; profile of anodized aluminium with trolley of powder-coated steel RAL 7016; with motorized stepless height adjustment from 197 - 230 cm, Wieland mains connection, concealed wiring; compartment for complete media equipment, integration of 19" units possible, ventilation grids at rear side, 2 lockable doors both at front and rear side, 4 castors, 2 of them lockable, d= 12.5 cm

Dimensions: ca. 150 x 70 x 193 cm, weight: ca. 150 kg

**MaxxMount trolley Twin with MultiMedia compartment**

**7514 000 300**



### Universal holder for flat screen displays with cable box

Display diagonal 40" - 65", vertically tiltable +15°/-5°, anthracite, Can hold max. 65 kg

**Universal holder for flat screen display with cable box**

**7514 100 200**



### Back wall cover

For covering the back wall of the universal holder for flat screen displays

**Back wall cover**

**7514 700 200**



### Universal holder Twin for 2 flat screen displays

Display diagonal 40" - 52", can hold max. 65 kg; vertically tiltable +15°/-5°, horizontal angle 5°

**Universal holder Twin for 2 flat screen displays**

**7514 200 300**



## Universal mount for whiteboard

Up to 78" (4:3) resp. 96" (16:9), for standard interactive boards from Polyvision, Smart, Promethean  
Weight: ca. 15 kg

**Universal mount for whiteboard**

**7514 300 100**



## Arm for ultra short throw projector

With projection ratio < 0.3, up to 10 kg weight, with universal projector holder

**Arm for ultra short throw projector**

**7514 400 100**



## Folding arm for short throw projector

With projection ratio 0.3 - 0.6, for projectors up to 10 kg weight, with universal projector holder, foldable, with pneumatic spring

**Folding arm for ultra short throw projector**

**7514 500 100**



## Tray for laptop

For laptop and power supply; can be mounted on both sides of the universal holder for whiteboard

**Tray for laptop**

**7514 600 100**



## Tray for keyboard

Size 30 x 20 cm, tilted 17°

**Tray for keyboard**

**7514 200 200**



## Universal tray

Size 45 x 25 cm

**Universal tray**

**7514 400 300**



## Tray for video camera

Size 26 x 24 cm

**Tray for video camera**

**7514 300 300**



## Holder for compact PC

Mounting on universal holder for flat screen display, for anti-theft protection

Inner dimensions for PC: max. 6.5 x 23 x 18-26.5 cm

**Holder for compact PC**

**7514 300 200**



## Holder for audio system

Adjustable, for mounting of AUDIO columns

Dimensions: ca. 26 x 22 x 10-15 cm

**Holder for audio system**

**7514 400 200**



## MultiMedia compartment for MaxxMount trolley

Compartment with space for complete media equipment, integration of 19" units possible, ventilation grids on the rear side, shelves, wiring box; 2 lockable doors both at front and rear side; to be mounted on trolley

Dimensions: ca. 135 x 57 x 56 cm

**MultiMedia compartment for MaxxMount trolley**

**7514 600 200**





## HEIGHT-ADJUSTABLE STANDS

For interactive whiteboards incl. projector mount  
in combination with short throw or ultra short throw projectors

- Pylons
- Adapts the working height to the user's size
- Lifting range 100 cm
- Sturdy construction for long life
- Mobile models fit through a door of 2 m height when not lifted
- TÜV GS certified – according to DIN EN 14434:2005-03

Model	Specification	Ref. No.
Height-adjustable stand, pylons, for ēno 2610/2810	Incl. universal holder for short throw projectors	7475 000 037
Height-adjustable stand, pylons, for ēno 2610/2810	Incl. holder for Sanyo PLC DWL2500/DXL2000	7475 000 044
Height-adjustable stand, pylons, for ēno 2610/2810	Incl. holder for EPSON EB-440/450/460	7475 000 038
Height-adjustable stand, pylons, for ēno triple 2620/2820	Incl. holder for EPSON EB-440/450/460	7475 000 043
Mobile height-adjustable stand, pylons, for ēno 2610/2810	Incl. holder for Sanyo PLC DWL2500/DXL2000	7475 000 045
Mobile height-adjustable stand, pylons, for ēno 2610/2810	Incl. universal holder for short throw projectors	7475 000 036
Mobile height-adjustable stand, pylons, for ēno 2610/2810	Incl. holder for EPSON EB-440/450	7475 000 039
Slow down mechanism for height adjustment	For 7475 000 036 / -37/ -38/ -39/ -43	7475 000 100
Bracket for active box set 50+	For mounting on mobile units 7475 000 036 / -39	7475 000 101
Laptop tray	For 7475 000 036 / -39	7475 000 104
Laptop tray	For 7475 000 045	7475 000 105

## H3O DISPLAY STANDS

For mobile large format LCD or Plasma solutions, supports are indispensable. In showrooms, meeting rooms and at trade shows, visual media and presentations are supported by display stands.

H3O display stands are designed for both being functional as well as stylish.

The exclusive stainless steel design fits in every surrounding.



Model	Premium	Essence	Solid	Next Generation Steps
Ref.No .	5100 000 102	5100 000 100	5100 000 105	5100 000 060
Max.d isplays ize	65"	50"	50"	50"
Depth	650 mm	800 mm	615 mm	577 mm
Width	930 mm	1100 mm	890 mm	650 mm
Height	2097 mm	2100 mm	2025 mm	2023 mm
Heightd isplayc entre	1675 mm	1505 mm	1675 mm	1625 mm
Weight	50 kg	30 kg	32 kg	20 kg
Otherf eatures	LED light, tray for camera (optional)	Tray for camera		
Materials	Stainless steel, acryl (LED) Base: shiny acryl (black)	Stainless steel Base: black painted steel	Stainless steel	Stainless steel



## DISPLAY MOUNTS

For plasma and TFT displays

Sturdy high-quality mounts for safe mounting of displays up to 65"

- Professional mounting of large displays
- Easy installation
- Compatible with many displays
- Also suitable for integration in AV furniture
- Non-tiltable, or tiltable +15° / -5°
- Two mounts:
  - 32" - 42": max. 600 x 400 mm distance of fixing points (VESA)
  - 40" - 65": max. 800 x 500 mm distance of fixing points (VESA)

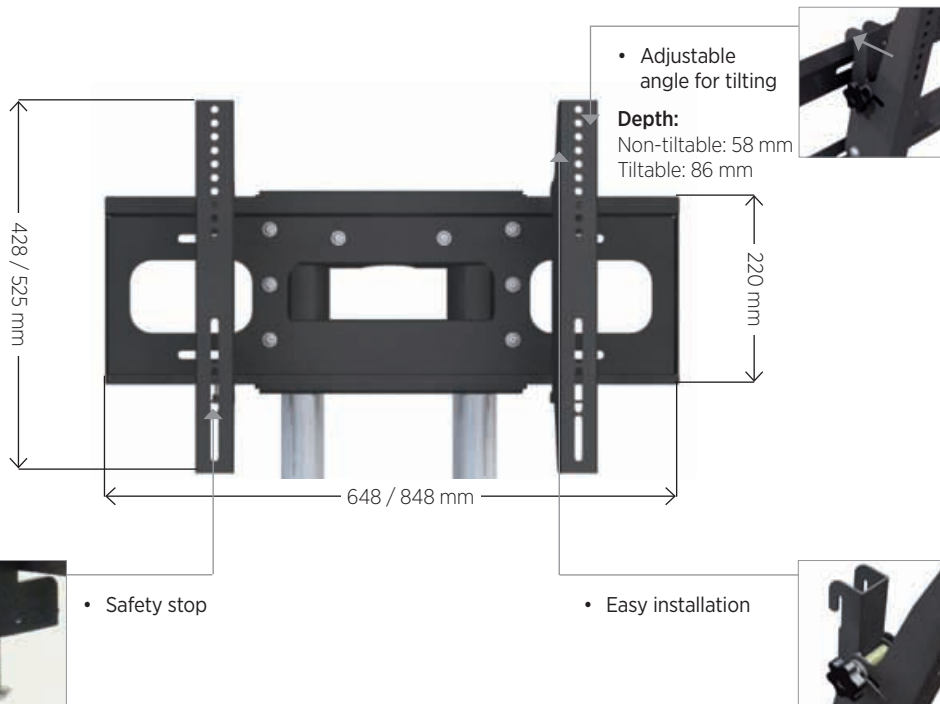
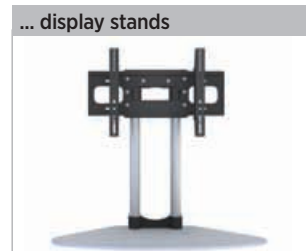

# Kindermann ceiling mounts for displays

## Consisting of 3 modules:

Mounts can be individually designed with the following components:

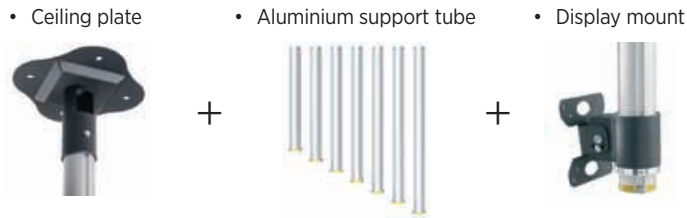

## Ceiling plates

Illustration	Model	Specification	Ref.N o.
	Ceiling plate Standard, anthracite Ceiling plate Standard, silver	Cable channel inside	7510 000 001 7510 000 001
	Ceiling plate H eavy	Cable channel inside	7510 000 010

## Aluminium support tubes

Illustration	Model	Specification	Ref.N o.
	Length 100 c m	Outer diameter 51 mm Inner diameter 45 mm, can be shortened Incl. safety screws for crash protection	7510 000 100
	Length 150 c m		7510 000 150
	Length 200 c m		7510 000 200
	Length 250 c m		7510 000 250

## Display mounts

Illustration	Model	Specification	Sized diagonal	Ref.N o.
	Display mount VESA 75 x 75 / 100 x 100	Cable channel inside		7510 000 050
	Display mount VESA 100 x 100 / 100 x 200 / 200 x 200			7510 000 054
	Universal mount	Can hold: 85 kg	32 - 42", non-tiltable	7510 000 056
			32 - 42", tiltable +15°/-5°	7510 000 057
		40 - 65", non-tiltable	7510 000 058	
		40 - 65", tiltable +15°/-5°	7510 000 059	

## Accessories for ceiling mounts

Illustration	Model	Ref.N o.
	Cover for ceiling cutout	7510 000 061
	PCh older Inner dimensions 294 x 224 x 72 mm	7510 000 062



## Kindermann wall mounts for flat screen displays

Illustration	Model	Size diagonal	Colour	Can hold	Ref. No.
	VESA 75/100/100 x 200/200 x 200 VESA 75/100/100 x 200/200 x 200	Tiltable 6.5°	silver	max. 40 kg	7511 000 001 7511 000 002
	Universal mount, non-tiltable	32" - 42" 40" - 65"	anthracite anthracite	max. 30 kg max. 40 kg	7511 000 005 7511 000 007
	Universal mount, tiltable +15°/-5°	32" - 42" 40" - 65"	anthracite anthracite	max. 50 kg max. 85 kg	7511 000 016 7511 000 018
	Universal mount, incl. holder for compact PC, e.g. Acer Veriton Inner dimensions PC holder: 29.9 x 36.2 x 7.7 cm	32" - 42", non-tiltable 32" - 42", tiltable +15°/-5° 40" - 65", non-tiltable 40" - 65", tiltable +15°/-5°	anthracite anthracite anthracite anthracite	max. 50 kg max. 50 kg max. 85 kg max. 85 kg	7511 000 019 7511 000 020 7511 000 025 7511 000 026
	Wall mount VESA 200 x 200 with swivelling arm Distance to the wall 10 cm up to max. 40 cm		anthracite	max. 20 kg	7511 000 03
	Universal wall mount with swivelling arm Distance to the wall 15 cm up to max. 60 cm	32" - 42", non-tiltable 32" - 42", tiltable +15°/-5° 40" - 65", non-tiltable 40" - 65", tiltable +15°/-5°	anthracite anthracite anthracite anthracite	max. 55 kg max. 55 kg max. 55 kg max. 55 kg	7511 000 021 7511 000 022 7511 000 023 7511 000 024

## Kindermann stands for flat screen displays

Illustration	Model	Sized iagonal	Heightd isplayc entre	Canh old	Ref.N o.
	<b>Flat screen stand Rolling</b>	32" - 42", non-tiltable 32" - 42", tiltable +15°/-5° 40" - 65", non-tiltable 40" - 65", tiltable +15°/-5°	140 cm 140 cm 140 cm 140 cm	max. 50 kg max. 50 kg max. 85 kg max. 85 kg	7512 000 041 7512 000 042 7512 000 043 7512 000 044
	<b>Flat screen stand Feet</b>	32" - 42", non-tiltable 32" - 42", tiltable +15°/-5° 40" - 65", non-tiltable 40" - 65", tiltable +15°/-5°	140 cm 140 cm 140 cm 140 cm	max. 50 kg max. 50 kg max. 85 kg max. 85 kg	7512 000 051 7512 000 052 7512 000 053 7512 000 054
	<b>Flat screen stand Adjust with height adjustment</b>	40" - 65", non-tiltable 40" - 65", tiltable +15°/-5°	144 - 178 cm 144 - 178 cm	max. 75 kg max. 75 kg	7512 000 033 7512 000 034
	<b>Flat screen stand Plate with metal plate</b>	32" - 42", non-tiltable 32" - 42", tiltable +15°/-5° 40" - 65", non-tiltable 40" - 65", tiltable +15°/-5°	140 cm 140 cm 140 cm 140 cm	max. 50 kg max. 50 kg max. 85 kg max. 85 kg	7512 000 061 7512 000 062 7512 000 063 7512 000 064
	<b>Flat screen stand Design</b>	32" - 42", non-tiltable 40" - 50", non-tiltable	140 cm 140 cm	max. 75 kg max. 75 kg	7512 000 071 7512 000 072
	<b>Flat screen stand Column</b>	40" - 65", non-tiltable 40" - 65", tiltable	max. 250 cm max. 250 cm	max. 75 kg max. 75 kg	7512 000 013 7512 000 014

## MULTIMEDIA CONNECTION SYSTEMS

Modular and versatile

The modular MultiMedia connection system can easily integrate computer, video, audio, control or network connections into socket systems, desktop casings, floor boxes and 19" racks.

It puts an end to ugly cables lying or hanging around!



Available as: soldering connection, plug-in version or clamp connection

• Cable and plug

• Gender changer

• Soldering connection

• Clamp connection

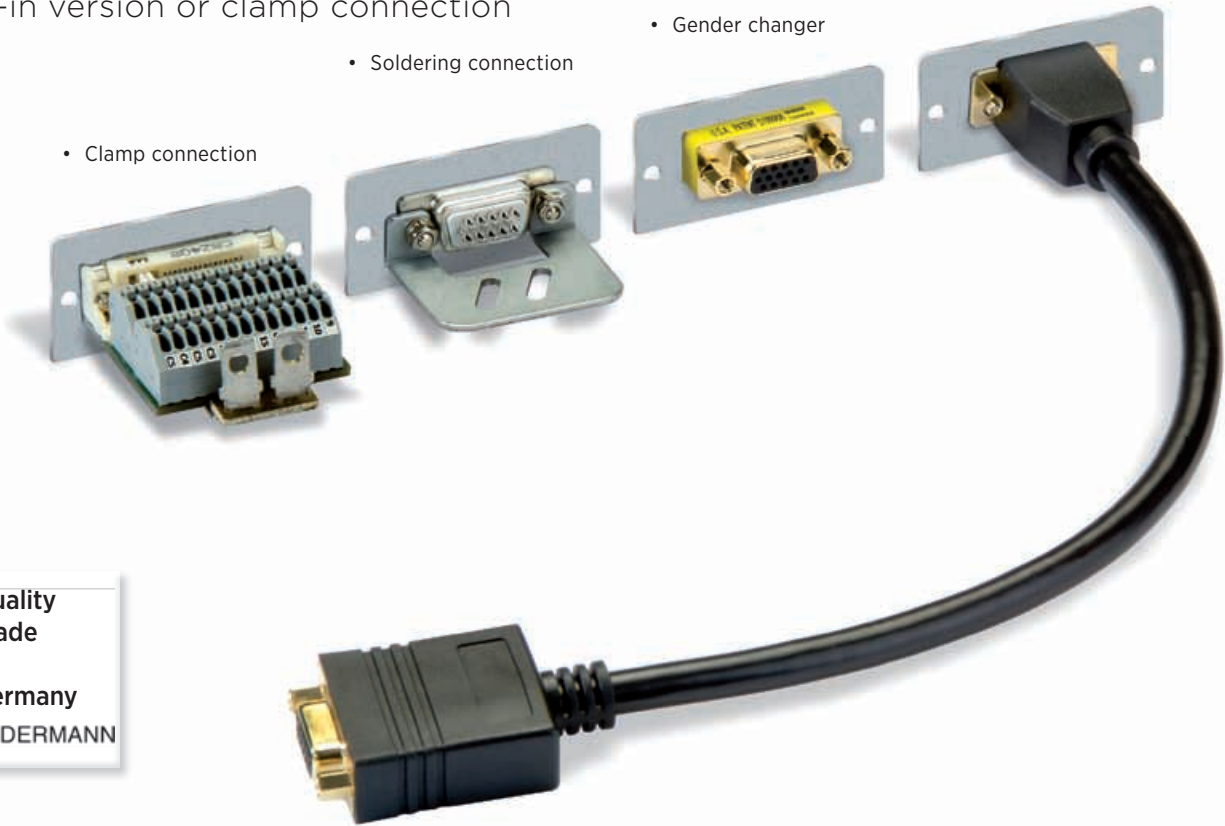

Quality made in Germany by KINDERMANN

### High quality

- The adapter plates are made of high-quality anodized aluminium or stainless steel.

### Ready for the future

- The modular system can be expanded any time by adding more adapter plates and thus is a true longterm investment.

### Female - female

- The adapter plates with cable and plug are supplied as f/f version unless otherwise stated.
- The cable length is 20 cm.



• Stainless steel



• Anodized aluminium

# ADAPTER PLATES

3 different sizes

	50 x 50 mm	54 x 54 / 55 x 55 mm	60 x 60 mm
Ref.No .	7444 000 xxx aluminium 7451 000 xxx stainless steel	7441 000 xxx	7442 000 xxx
Illustration			
Suitable for	Socket systems Desktop casings Floor boxes 19" rack patch panels	Socket systems	Socket systems "Feller"

## COMPATIBLE WITH SOCKET SYSTEMS

from well-known European manufacturers! Other versions on demand!

### Berker

54 x 54 mm	SI, B1, B3, B7 glass, module 2, arsys, K.1/K.5
50 x 50 mm	SI, B1, B3, B7 glass, module 2, arsys, K.1/K.5

### Busch-Jaeger

54 x 54 mm	reflex SI (linear), duro 2000 Si (linear), pure stainless steel
50 x 50 mm	reflex SI (linear), duro 2000 Si (linear), solo, future (linear), carat, alpha exclusive, alpha nea, impuls, busch-xcent pure stainless steel

### Elso

54 x 54 mm	riva, scala, fashion (only in combination with ELSO adapter frame 55 x 55)
------------	---

### Feller

60 x 60 mm	edizio
------------	--------

### Gira

54 x 54 mm	event, E2, E22 white, Esprit, Standard 55
50 x 50 mm	event, E2, esprit, standard 55, stainless steel, aluminium, s-color, f100, s-classic, e22

### Hager/Tehalit

50 x 50 mm	kallysto pure, kallysto stil, kallysto art
------------	--

### Jung

54 x 54 mm	a 500, as 500, as universal, a plus, a creation gold, ls plus*, ls 990*, stainless steel*, aluminium*, anthracite*, chrome*; (*with additional adapter frame)
50 x 50 mm	a 500, as 500, as universal, a plus, a creation, cd 500, st 550, cd universal, cd plus, ls plus, ls 990, stainless steel, aluminium, anthracite, chrome, gold, fd-desgin

### Kopp

54 x 54 mm	milano
------------	--------

### Legrand-BTicino

50 x 50 mm	creo, galea life
------------	------------------

### Merten

54 x 54 mm	atelier, m-arc, m-plan, m-plan II, m-smart, m1, m-star
50 x 50 mm	atelier, m-arc, m-plan, m-plan II, m-smart, m1, m-star, artec, antik, octocolor, system basis, system surface, system m

### Peha

50 x 50 mm	standard, dialog, nova, aura
60 x 60 mm	nova, aura

### Presto-Vedder

50 x 50 mm	regina, alessa, alessa plus, fiorena
------------	--------------------------------------

### Siemens

54 x 54 mm	delta i system, delta vita, delta miro
50 x 50 mm	delta i system, delta vita, delta miro, delta profil, delta style, delta ambiente







### Please note!

If the inner dimensions of the socket cover differ from the standard sizes 50 x 50, 54 x 54 or 55 x 55 mm, an extra adapter frame is needed in addition to the socket cover and the mounting frame (No. 7442 000 001), in order to reduce the inner dimensions to 50 x 50 mm.







This additional adapter frame is supplied by the manufacturer of the socket systems.



## Miscellaneous

Adapter plates sized			50 x 50 mm	50 x 50 mm	54 x 54 mm	60 x 60 mm
Illustration	Model	Connection	Aluminium	Stainless steel	Aluminium	Aluminium
	Faceplate (half size) Faceplate (full size)		7444 000 400 7444 000 500	7451 000 400 7451 000 500	7441 000 400 7441 000 500	7442 000 400 7442 000 500
	Mains switch (full size plate) only available pre-mounted in desktop casings		7444 000 200	7451 000 200		
	Faceplate with cable outlet for cables up to 12 or 9 mm diameter		7444 000 444	7451 000 444		
	Push-button, stainless steel, 48 VDC / 125 mA e.g. for control of selectors (e.g. No. 5816 000 007) with contact inputs	Soldering	7444 000 441	7451 000 441		
	Button, stainless steel 30 V DC / 500 mA	Soldering	7444 000 442	7451 000 442		
	Push-button, stainless steel with blue LED, 48 VDC / 500 mA, with light ring 9 - 12 V DC, 1 x open / close	Soldering	7444 000 443	7451 000 443		
	Button panel, 8-fold with blue LEDs, 48 V DC / < 50 mA, light 12 - 24 V e.g. for switcher with contact inputs etc.	Screw+clamp	7444 000 445			

## Computer / video

Adapter plates sized			50 x 50 mm	50 x 50 mm	54 x 54 mm	60 x 60 mm
Illustration	Model	Connection	Aluminium	Stainless steel	Aluminium	Aluminium
	VGA (HD15) Required installation depth for cable+plug connection: 47 mm for clamp connection: 42 mm	Soldering Cable+plug Gender changer Clamp	7444 000 401 7444 000 501 7444 000 601 7444 000 701	7451 000 401 7451 000 501 7451 000 601	7441 000 401 7441 000 501 7441 000 701	7442 000 401 7442 000 501
	VGA to BNC 5 Required installation depth: 47 mm	Cable+plug	7444 000 507		7441 000 507	7442 000 507
	VGA active (full size plate) with integrated VGA amplifier 1:1; 400 MHz and with external power supply 230 V / 12 V DC Required installation depth: 40 mm	Cable+plug	7444 000 509	7451 000 509	7441 000 509	
	DVI-I (24 + 5 pin) Required installation depth: for cable+plug connection: 65 mm for clamp connection: 42 mm	Soldering Cable+plug Cable+plug	7444 000 402 7444 000 502 7444 000 702	7451 000 502	7441 000 402 7441 000 502 7441 000 702	7442 000 502
	HDMI Required installation depth: for cable+plug connection: 52 mm for clamp connection: 42 mm	Cable+plug Clamp	7444 000 540 7444 000 740	7451 000 540	7441 000 540 7441 000 740	7442 000 540
	DVI-D to HDMI Required installation depth: 52 mm	Cable+plug	7444 000 580		7441 000 580	
	HDMI to DVI Required installation depth: 52 mm	Cable+plug	7444 000 581		7441 000 581	





## Computer / video

Adapter plates sized			50 x 50 mm	50 x 50 mm	54 x 54 mm	60 x 60 mm
Illustration	Model	Connection	Aluminium	Stainles steel	Aluminium	Aluminium
	<b>Video (cinch)</b> Required installation depth for cable+plug connection: 47 mm	Soldering Cable+plug	7444 000 403 7444 000 503	7451 000 403 7451 000 503	7441 000 403 7441 000 503	7442 000 403 7442 000 503
	<b>Video to 1 x BNC</b> Required installation depth: 47 mm	Cable+plug	7444 000 535		7441 000 535	
	<b>S-video (4 pin MiniDIN)</b> Required installation depth for cable+plug connection: 47 mm	Soldering Cable+plug	7444 000 404 7444 000 504	7451 000 504	7441 000 404 7441 000 504	7442 000 404 7442 000 504
	<b>S-video to 2 x BNC</b> Required installation depth: 47 mm	Cable+plug	7444 000 536		7441 000 536	
	<b>Video/S-video (cinch/4 pin MiniDIN)</b> Required installation depth for cable+plug connection: 47 mm	Soldering Cable+plug	7444 000 405 7444 000 505	7451 000 505	7441 000 405 7441 000 505	7442 000 405 7442 000 505
	<b>Component video (3 x cinch)</b> Required installation depth for cable+plug connection: 47 mm	Soldering Cable+plug	7444 000 406 7444 000 506		7441 000 406 7441 000 506	7442 000 406 7442 000 506
	<b>Scart</b>	Soldering			7441 000 408	
	<b>BNC - 1-fold</b>	Gender changer	7444 000 537		7441 000 537	
	<b>BNC - 2-fold</b>	Gender changer	7444 000 538		7441 000 538	
	<b>BNC - 5-fold, (full size plate)</b>	Gender changer	7444 000 539		7441 000 539	
	<b>F socket - 2-fold for HF signals</b> (e.g. for satellite receiver)				7441 000 541	





## Audio - passive

Adapter plates sized			50 x 50 mm	50 x 50 mm	54 x 54 mm	60 x 60 mm
Illustration	Model	Connection	Aluminium	Stainless steel	Aluminium	Aluminium
	<b>Audio L/R (cinch)</b> Required installation depth for cable+plug: 47 mm	Soldering Cable+plug	7444 000 410 7444 000 510	7451 000 410 7451 000 510	7441 000 410 7441 000 510	7442 000 410 7442 000 510
	<b>Audio jack (3.5 mm stereo)</b> Required installation depth for cable+plug: 47 mm	Soldering Cable+plug	7444 000 411 7444 000 511	7451 000 411 7451 000 511	7441 000 411 7441 000 511	7442 000 411 7442 000 511
	<b>Audio jack (6.3 mm stereo)</b>	Soldering	7444 000 417		7441 000 417	
	<b>XLR 3-pin (full size plate)</b> Neutrik® socket (f)	Soldering (XLR socket - f)	7444 000 412	7451 000 412	7441 000 412	7442 000 412
		Soldering (XLR plug - m)	7444 000 416		7441 000 416	7442 000 416
	<b>XLR 3-pin plug (m) - 2-fold (full size plate)</b>	Clamp	7444 000 578		7441 000 578	
	<b>Speakon 4-pin (full size plate)</b> Neutrik® socket (f) Required installation depth: 40 mm (with soldering)	Soldering	7444 000 413	7451 000 413	7441 000 413	7442 000 413
	<b>Loudspeaker</b> Suitable for loudspeaker cables or pin plugs up to 4 mm <sup>2</sup>	Screw+clamp	7444 000 414		7441 000 414	7442 000 414
	<b>Volume control (Poti, passive) (cinch L/R) (full size plate)</b> For Line signals, e.g. of notebooks, DVD players Required installation depth: 35 mm	Cable+plug	7444 000 518		7441 000 518	
	<b>Audio 2 x cinch / 1 x jack (3.5 mm stereo) (full size plate)</b> With volume control/Poti, passive Symmetric output for Line signals, e.g. of DVD players	Clamp	7444 000 418		7441 000 418	
	<b>Audio 1 x XLR socket (f) (full size plate)</b> With volume control/Poti, passive Symmetric output	Clamp	7444 000 419		7441 000 419	

## Data

Adapter plates sized			50 x 50 mm	50 x 50 mm	54 x 54 mm	60 x 60 mm
Illustration	Model	Connection	Aluminium	Stainless steel	Aluminium	Aluminium
	Serial RS232 (9-pin SubD)	Soldering Cable+plug	7444 000 420 7444 000 520	7451 000 420	7441 000 420 7441 000 520	7442 000 420 7442 000 520
	PS/2	Soldering Cable+plug	7444 000 521		7441 000 421 7441 000 521	
	USB (2.0 compatible) A-socket (f)/A-socket (f) Required installation depth: 43 mm	Cable+plug	7444 000 522	7451 000 522	7441 000 522	7442 000 522
	USB (2.0 compatible) B-socket (f)/A-socket (f) Required installation depth: 43 mm	Cable+plug	7444 000 525	7451 000 525	7441 000 525	7442 000 525
	USB - CAT 5 With integrated USB extender (No. 5772 000 001) for USB 1.1, Max. length CAT 5 cable between sender and receiver: 45 m	Cable+plug	7444 000 524		7441 000 524	

## Network

Adapter plates sized			50 x 50 mm	50 x 50 mm	54 x 54 mm	60 x 60 mm
Illustration	Model	Connection	Aluminium	Stainless steel	Aluminium	Aluminium
	CAT 5 (RJ45) Gender changer (1:1)		7444 000 523	7451 000 523	7441 000 523	7442 000 523
	CAT 6/6A (RJ45) Socket (f) "Setec"	Cut+clamp	7444 000 423	7451 000 423	7441 000 423	7442 000 423
	CAT 6 (RJ45) Socket (f) "BTR"	Gender changer (1:1)	7444 000 526	7451 000 526	7441 000 526	7442 000 526
	CAT 6/6A (RJ45) Socket (f) "Rutenbeck" Flexible cable outlet for limited installation space Required installation depth: 26 mm	Cut+clamp	7444 000 425	7451 000 425	7441 000 425	
	CAT 7 Socket (f) "Nexans" Certified up to 1000 MHz downward compatible to RJ45 (CAT 5/CAT 6)	Cut+clamp	7444 000 424	7451 000 424	7441 000 424	7442 000 424



## Combinations

Adapter plates sized			50 x 50 mm	50 x 50 mm	54 x 54 mm	60 x 60 mm
Illustration	Model	Connection	Aluminium	Stainless steel	Aluminium	Aluminium
	<b>Video, audio L/R</b> Required installation depth: 47 mm	Soldering Cable+plug	7444 000 430 7444 000 530	7451 000 430 7451 000 530	7441 000 430 7441 000 530	7442 000 430 7442 000 530
	<b>Audio L/R, S-video</b> Required installation depth: 47 mm	Soldering Cable+plug	7444 000 431 7444 000 531		7441 000 431 7441 000 531	7442 000 431 7442 000 531

## Adapter plates for installation cable 13/19-pin

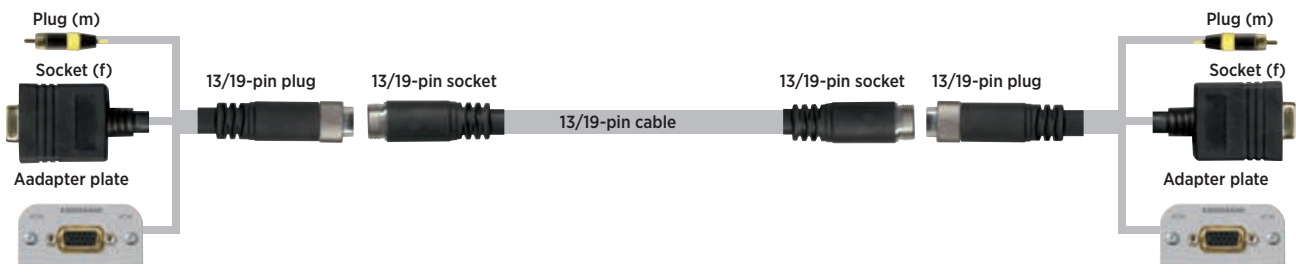

### Please note!

You can find suitable adapter plates for the 13/19-pin installation cable on page 104 - 105

## The modular solution for 19" rack panels

- Available in 2 versions:  
as patch panel with mains connection and switch or  
as patch panel for adapter plates
- Integration of MultiMedia interfaces in 19" racks
- For individual combination of adapter plates
- Colour: black, powder-coated RAL 9005



Model	Specification	Ref. No.
<b>19" patch panel</b> with 2 x 230 V socket, mains switch and rear Schuko connection	For connecting multiple sockets etc. With additional space for 4 full size or 8 half size plates 7444-xxx (50 x 50 mm), 2 rack units	7446 000 011
<b>19" patch panel</b>	For adapter plates 7444-xxx (50 x 50 mm) With space for 7 full size or 14 half size plates, 2 rack units	7446 000 002

Installation example  
of a socket cover  
with on-wall casing

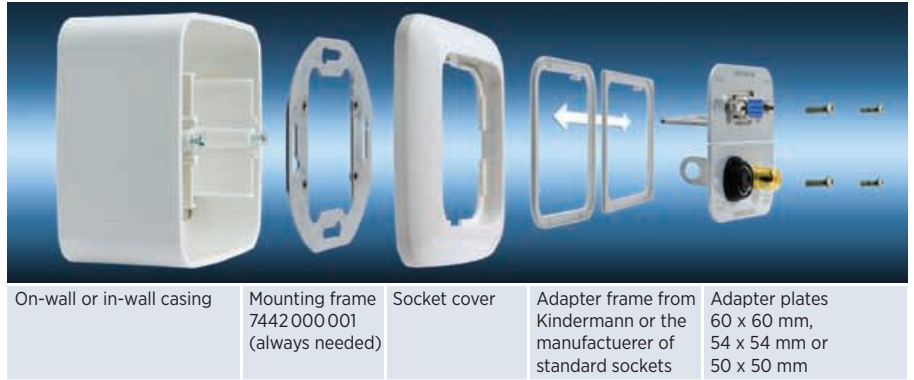

### Mounting material for socket systems

Illustration	Model	Specification	Ref.N o.
	Mounting frame for adapter plates 50 x 50 mm and 54 x 54 mm	With adapter frame for using adapter plates 54 x 54 mm (7441 000 xxx) in socket systems sized 55 x 55 mm	7442 000 001
	Mounting frame 1-gang for adapter plates 60 x 60 mm	System Feller "Edizio"	7442 000 003
	Mounting frame 2-gang or adapter plates 60 x 60 mm	System Feller "Edizio"	7442 000 004
	Socket cover 1-gang and mounting frame	Busch Jaeger, Reflex SI, white, suitable for adapter plates sized 54 x 54 mm (7441 000 xxx)	7441 000 001
	Socket cover 2-gang and 2 mounting frames	Busch Jaeger, Reflex SI, white, suitable for adapter plates sized 54 x 54 mm (7441 000 xxx)	7441 000 002
	Main socket for Schuko plug	Busch-Jaeger, Reflex SI, white	7441 000 010
	On-wall casing (1-gang)	Busch-Jaeger, Reflex SI, white, incl. pre-cut cable outlet, suitable for 7441 000 001	7441 000 003
	On-wall casing (2-gang)	Busch-Jaeger, Reflex SI, white, incl. pre-cut cable outlet, suitable for 7441 000 002	7441 000 004
	In-wall casing (1-gang)	Depth: 47 mm Depth: 61 mm	7441 000 005 7441 000 007
	In-wall casing (2-gang)	Depth: 47 mm Depth: 75 mm	7441 000 006 7441 000 008





## MODULAR SYSTEM FOR FLOOR BOXES

- For OBO/Ackermann, Tehalit and Electraplan floor boxes
- The module holders replace the casings GB2 and GB3 of OBO Ackermann and Tehalit
- For Electraplan the casings GB2D and GB3D are required
- For individual combination of adapter plates 50 x 50 mm (7444 000 xxx)
- Adapter plates optional

**Please note:**

For available adapter plates see page 84 - 89

### Module holders for floor boxes

Illustration	Model	Specification	Ref.N o.
	<b>Module holder GB2 for Ackermann and Tehalit</b>	For 4 half size adapter plates or 2 full size adapter plates 7444 000 xxx	7445 000 002
	<b>Module holder GB3 for Ackermann and Tehalit</b>	For 6 half size adapter plates or 3 full size adapter plates 7444 000 xxx	7445 000 003
	<b>Module holder for Electraplan</b>	For 2 half size adapter plates or 1 full size adapter plate 7444 000 xxx Up to 2 holders are required for GB2D or GBV2T, up to 3 holders are required for GB3D or GBV3T.	7445 000 004

### Floor box Ackermann GESR7/10 U

Illustration	Model	Specification	Ref.N o.
	<b>Floor box AckermannG ESR7/10</b>	Equipped with 4 mains sockets (Schuko) * and 2 module holders GB2. For up to 8 half size plates or 4 full size plates 50 x 50 mm. Mains connected with 3-pin Wieland plug GST 18 (supplied with GST 18 adapter for easy installation). Adapter plates optional. Other versions on demand.	7445 000 100





## CABLEPORT STANDARD

The Kindermann desktop CablePorts put an end to messing around with the wiring on the conference table.

In addition to pre-configured desktop CablePorts various combinations of mains, AV and data interfaces can be realized in the desktop casing.

When needed, the lid is opened. After plugging in, the CablePort can be closed again, and the connections are no longer visible. The cable outlet is covered by an integrated brush.

The housing can be installed level to the desktop.

### Available in 2 versions:

- Powder-coated, RAL 9006
- Stainless steel (polished)

Custom-made versions in other RAL colours can be supplied on demand!

### Features

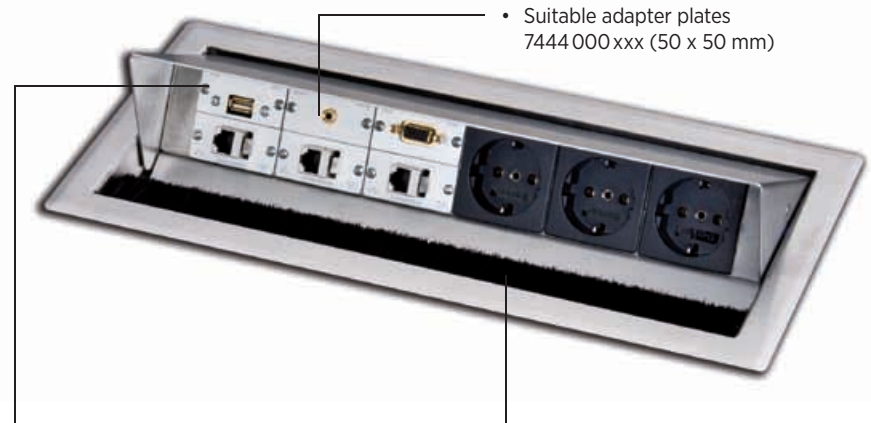

- Suitable adapter plates 7444 000 xxx (50 x 50 mm)
- Can be individually fitted with mains sockets and adapter plates. Each section can hold two half size plates or one full size plate.
- Brush and integrated blind



• Empty casing, open



• Empty casing, closed





• Connections with cable and plug



## CABLEPORT STANDARD

Installation depth 83 mm, radius R5,  
Mains connection with 3-pin Wieland plug GST 18  
(GST 18 connector supplied)

### Pre-mounted desktop CablePorts

Model	2 full size adapter plates	4 full size adapter plates	6 full size adapter plates	6 full size adapter plates + Pixie+
Illustration				
Pre-mounted with	1 x mains 1 x VGA 1 x Audio (jack) 1 x Cat 5	2 x mains 1 x VGA 1 x Audio (jack) 2 x Cat 5	3 x mains 1 x VGA 1 x Audio (jack) 1 x USB 3 x Cat 5	2 x mains 1 x Pixie+ 2 x empty modules
Outer dimensions	183 x 180 mm	287 x 180 mm	392 x 180 mm	392 x 180 mm
Cutout	155 x 160 mm	262 x 160 mm	365 x 160 mm	365 x 160 mm
Powder-coated RAL 9006				
Ref. No.	7444 000 003	7444 000 008	7444 000 009	
Stainless steel, polished				
Ref. No.	7444 000 005	7444 000 006	7444 000 007	7444 000 0090

### Desktop CablePorts for 2 adapter plates, for individual configuration

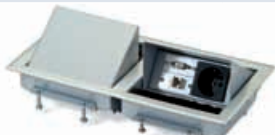
Model	2 full size adapter plates	2 x 2 full size adapter plates, access from both sides		
Illustration				
Pre-mounted with	1 x mains 1 x empty module	2 x mains	1 x mains 1 x VGA 1 x Audio (jack) 1 x Cat 5 on each side	1 x mains 1 x empty module on each side
Outer dimensions	183 x 180 mm	355.5 x 180 mm		
Cutout	155 x 160 mm	327 x 160 mm		
Powder-coated RAL 9006				
Ref. No.	7444 000 031	7444 000 032	7444 000 103	7444 000 131
Stainless steel, polished				
Ref. No.	7444 000 041	7444 000 042	7444 000 105	7444 000 141

### Desktop CablePorts for 4 adapter plates, for individual configuration

Model	4 full size adapter plates				
Illustration					
Pre-mounted with	Empty casing for 4 adapter plates	1 x mains 3 x empty module	2 x mains 2 x empty module	3 x mains 1 x empty module	4 x mains
Outer dimensions	287 x 180 mm				
Cutout	262 x 160 mm				
Powder-coated RAL 9006					
Ref. No.	7444 000 070	7444 000 071	7444 000 072	7444 000 073	7444 000 074
Stainless steel, polished					
Ref. No.	7444 000 050	7444 000 051	7444 000 052		7444 000 054

## Desktop CablePorts for 6 adapter plates, for individual configuration

<b>Model</b>	6 full size adapter plates					
<b>Illustration</b>						
<b>Pre-mounted with</b>	Empty casing 6 x empty module	1 x mains 5 x empty module	2 x mains 4 x empty module	3 x mains 3 x empty module	4 x mains 2 x empty module	6 x mains
<b>Outer dimensions</b>	392 x 180 mm					
<b>Cutout</b>	365 x 160 mm					
<b>Powder-coated R AL9 006</b>						
<b>Ref.No .</b>	7444 000 080	7444 000 081	7444 000 082	7444 000 083	7444 000 084	7444 000 086
<b>Stainless steel, polished</b>						
<b>Ref.No .</b>			7444 000 062	7444 000 063	7444 000 064	

## Desktop CablePorts with Swiss mains sockets

Other versions on demand

<b>Model</b>	2 full size adapter plates		4 full size adapter plates		6 full size adapter plates	
<b>Illustration</b>						
<b>Pre-mounted with</b>	1 x mains 1 x VGA 1 x Audio (jack) 1 x Cat 5	1 x mains 1 x empty module	2 x mains 1 x VGA 1 x Audio (jack) 2 x Cat 5	2 x mains 2 x empty module	3 x mains 3 x empty module	2 x mains 1 x Pixie+ 2 x empty module
<b>Outer dimensions</b>	183 x 180 mm		287 x 180 mm		392 x 180 mm	
<b>Cutout</b>	155 x 160 mm		262 x 160 mm		365 x 160 mm	
<b>Powder-coated R AL9 006</b>						
<b>Ref.No .</b>		7444 0CH 031	7444 0CH 008	7444 0CH 072	7444 0CH 083	
<b>Stainless steel, polished</b>						
<b>Ref.No .</b>	7444 0CH 005	7444 0CH 041		7444 0CH 052		7444 0CH 090

Please ask for other country versions, e.g. with French, Italian, UK mains sockets etc.



## Connection cables for desktop CablePorts

Illustration	Model	Specification	Ref.N o.
	Connection cable mains (Schuko) - m / Wieland GST 18 - f	1 m 2 m 3 m 5 m 8 m	7444 000 301 7444 000 302 7444 000 303 7444 000 305 7444 000 308
	Wieland extension f / m GST 18	1 m 2 m 3 m	7444 000 321 7444 000 322 7444 000 323
	Wieland distributor with lamp	1 input (m), 3 outputs (f)	7444 000 340

## Cable collector

Illustration	Model	Specification	Ref.N o.
	Cable collector	Size: 320 x 170 x 85 mm For storing away power supply units and for connecting cables of the desktop CablePort. Suitable for 13/19-pin installation cable	7446 000 020

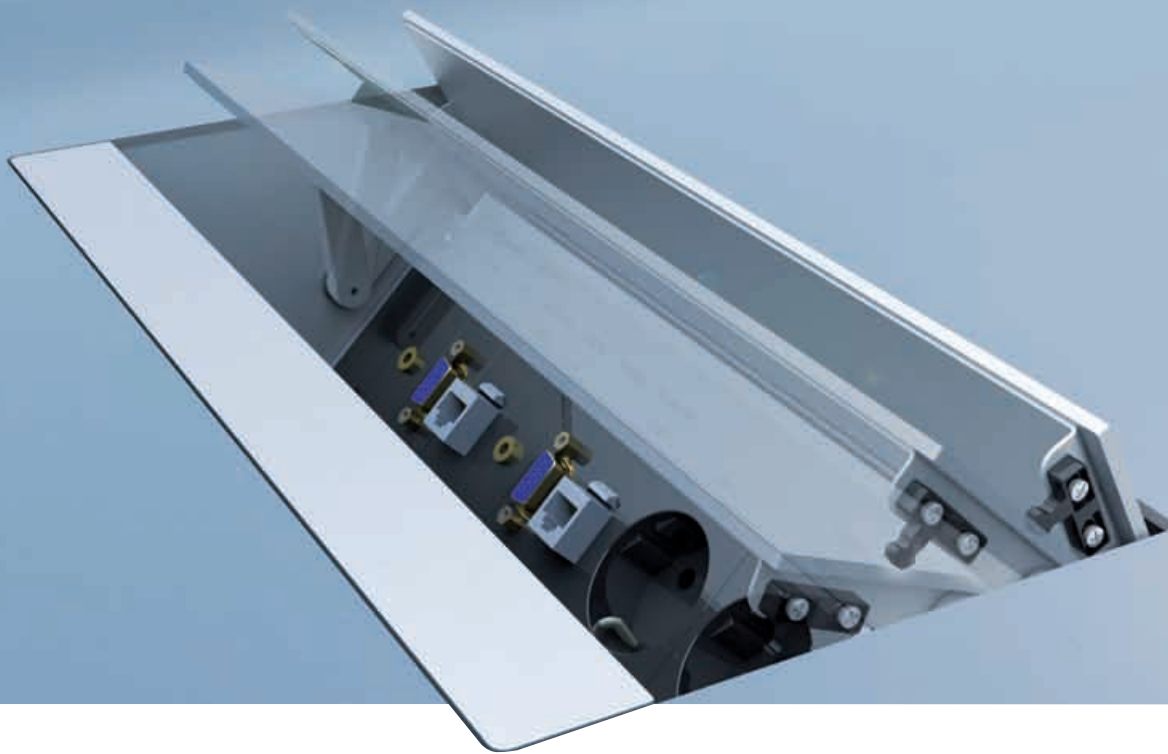

## CABLEPORT FLEX

The newly developed CablePort Flex is Kindermann's elegant cable management solution for mains, AV, data and network connections to meet higher demands.

The focus is on a high-value design and a comfortable operation. A slight touch on the lid, and it opens smoothly and nearly completely slides into the casing. The sloping

panel inside makes it easy to plug in; moreover there is enough space to harbour power supplies and cables.

Flex is not only the name of the product but also of the whole programme: beside a standard version with a lid of anodized aluminium it is possible to design the surface according to your wishes, no matter if you prefer veneer, a glass

plate or fine leather - nearly all wishes can be fulfilled.

It is self-evident that you can choose and arrange the interfaces according to your needs.

### Features:

Smooth automatic opening of the lid by a finger tip. Open lid slides nearly completely into the casing.

Power supply via Wieland quick connection system

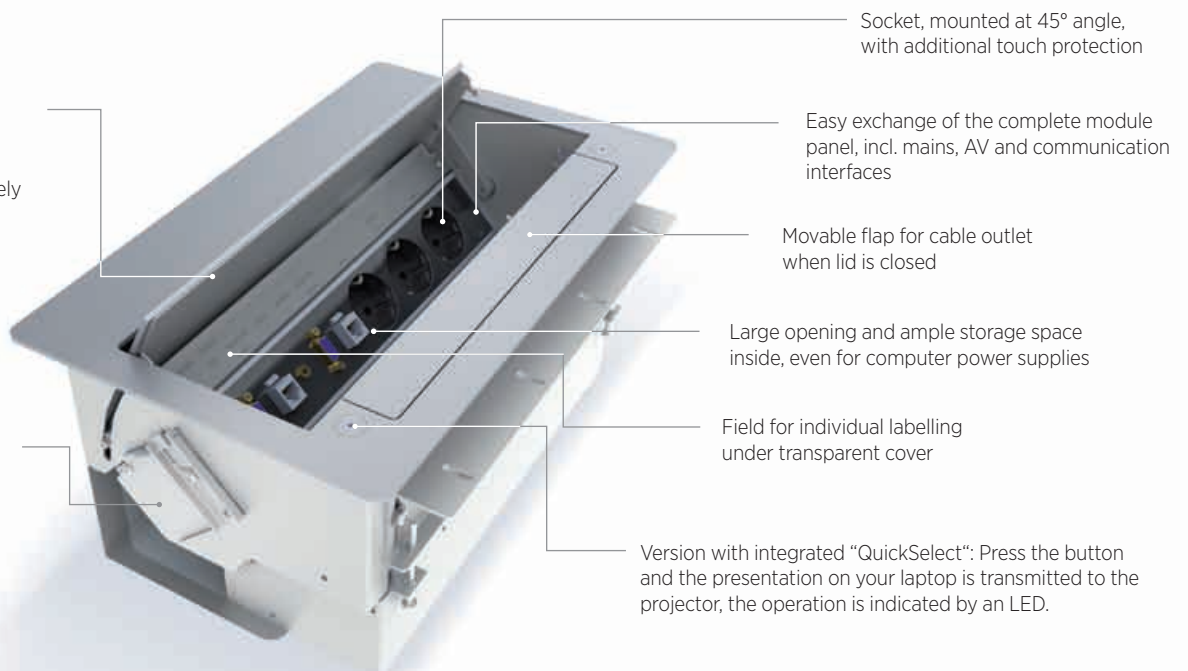

## Different ways of integrating CablePort Flex

### The CablePort Flex is available in different versions

A very attractive design can be achieved by installing the basic module flush with the surface of the desk and without a mounting frame. For this a careful preparation of the desktop during the manufacturing process is a prerequisite.

Ready-made tables need an additional aluminium frame and a precise cutout of the desktop to integrate the module level with the surface.

The on-surface aluminium frame requires only a simple cutout which will be fully covered by its rim. The installation height is only 1.5 mm, which makes the built-in frame appear nearly flush with the surface.



### The special highlight:

The basic module can be fitted with individual surfaces on its lid, e. g. the veneer of the desktop, or with a special design, e.g. a leather or glass surface.

### Installation example: aluminium frame flush with desktop





1

## Basic module

### For frameless installation in desktop

- With lid of anodized aluminium
- Inner parts powder-coated, silver, RAL 9006
- Installation depth: ca. 160 mm
- For desktops 15-40 mm thick

Empty casing for module panel for 4 adapter plates, cutout ca. 244 x 193 mm	7448 000 010
Empty casing for module panel for 6 adapter plates, cutout ca. 334 x 193 mm	7448 000 020



2

## Anodized aluminium frame with rim, to be mounted on the desktop

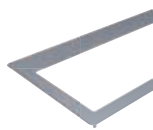

For 4 adapter plates Dimensions: 271 x 220 mm	7448 000 011
For 6 adapter plates, Dimensions: 361 x 220 mm	7448 000 021

## Anodized aluminium frame, to be mounted level with the desktop



For 4 adapter plates, Dimensions: 271 x 220 mm	7448 000 012
For 6 adapter plates, Dimensions: 361 x 220 mm	7448 000 022

1

## Basic module for individual surfaces

### For frameless installation in desktop

- Inner parts powder-coated, silver, RAL 9006
- Installation depth: ca. 160 mm
- For desktops 15-40 mm thick

Empty casing for module panel for 4 adapter plates, cutout 244 x 193 mm	7448 000 030
Empty casing for module panel for 6 adapter plates, cutout 334 x 193 mm	7448 000 040

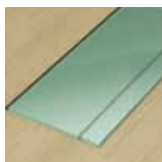

### Please note:

The individual surface must be provided and fitted by the manufacturer of the furniture, the joiner or the technician.



## CablePort Flex with QuickSelect

- With lid of anodized aluminium
- Pre-mounted with mains, AV and network interfaces and integrated QuickSelect/S (Casing for 6 adapter plates with 2 QuickSelect/S)
- Metal parts powder-coated, silver, RAL 9006
- Installation depth: ca. 175 mm
- For desktops 15 - 40 mm thick
- For details about the Kindermann QuickSelect see pages ...
- Order suitable aluminium frame!

Anodized aluminium frame with rim,  
to be mounted on desktop

<b>For 4 adapter plates and CablePort QuickSelect</b> Dimensions: 271 x 220 mm	<b>7448 000 013</b>
<b>For 6 adapter plates and CablePort QuickSelect</b> Dimensions: 361 x 220 mm	<b>7448 000 023</b>

Anodized aluminium frame,  
for integration level with the desktop

<b>For 4 adapter plates and CablePort QuickSelect</b> Dimensions: 271 x 220	<b>7448 000 014</b>
<b>For 6 adapter plates and CablePort QuickSelect</b> Dimensions: 361 x 220 mm	<b>7448 000 024</b>

<b>Casing with 4 adapter plates</b> , pre-mounted with 2 x mains, VGA, audio jack, 2 x LAN; "SHOW-Me"-button with LED light	<b>7448 000 001</b>
<b>Casing with 6 adapter plates</b> , pre-mounted with, 3 x mains, 2 x VGA, 2 x audio jack, 2 x LAN; 2 x "SHOW-Me" button with LED light	<b>7448 000 002</b>

3

## Module panel

- Anodized aluminium
- Safety socket, mounted at 45° angle, with touch protection
- For adapter plates (7448 000 xxx)
- Mains connection through Wieland GST 18 plug (suitable connection cable Wieland GST 18 to Schuko plug see page 94 / 95)



<b>Module panel for 4 full size adapter plates</b> , pre-mounted with 2 x mains, 1 x VGA, 1 x audio jack, 2 x Cat5 (Gender changer)	<b>7448 000 110</b>
<b>Module panel for 4 plates</b> , 4 x empty	<b>7448 000 100</b>
<b>Module panel for 4 plates</b> , 1 x mains, 3 x empty	<b>7448 000 101</b>
<b>Module panel for 4 plates</b> , 2 x mains, 2 x empty	<b>7448 000 102</b>
<b>Module panel for 4 plates</b> , 3 x mains, 1 x empty	<b>7448 000 103</b>
<b>Module panel for 4 plates</b> , 4 x mains	<b>7448 000 104</b>

<b>Module panel for 6 full size adapter plates</b> , pre-mounted with 3 x mains, 2 x VGA, 2 x audio jack, 2 x Cat5 (Gender changer)	<b>7448 000 210</b>
<b>Module panel for 6 plates</b> , 6 x empty	<b>7448 000 200</b>
<b>Module panel for 6 plates</b> , 1 x mains, 5 x empty	<b>7448 000 201</b>
<b>Module panel for 6 plates</b> , 2 x mains, 4 x empty	<b>7448 000 202</b>
<b>Module panel for 6 plates</b> , 3 x mains, 3 x empty	<b>7448 000 203</b>
<b>Module panel for 6 plates</b> , 4 x mains, 2 x empty	<b>7448 000 204</b>
<b>Module panel for 6 plates</b> , 5 x mains, 1 x empty	<b>7448 000 205</b>
<b>Module panel for 6 plates</b> , 6 x mains	<b>7448 000 206</b>

4

## Adapter plates

All adapter plates with cable and plug are supplied as f - m version and with 3 m connection cable.

Illustration	Model	Connection	Ref.No .
	<b>Faceplate</b> Width 22,5 mm Width 45 mm		7448 000 400 7448 000 500
	<b>Button</b> , stainless steel, 30V DC / 500 mA	Soldering	7448 000 442

Illustration	Model	Connection	Ref.N o.
	<b>Push-button</b> , stainless steel, for control of VGA selectors, 48 V DC/125 mA	Soldering	7448 000 441
	<b>Button</b> , stainless steel, with blue LED light ring (9-12 V), 48 V DC/500 mA	Soldering	7448 000 443



























Illustration	Model	Connection	Ref.No .
	VGA	Soldering Cable+plug	7448 000 401 7448 000 501
	VGA active with integrated VGA amplifier, 400 MHz with external power supply	Cable+plug Length ca. 20 cm	7448 000 509
	DVI-I	Cable+plug	7448 000 502
	HDMI	Cable+plug	7448 000 540
	Video (cinch)	Soldering Cable+plug	7448 000 403 7448 000 503
	S-video	Soldering Cable+plug	7448 000 404 7448 000 504
	Video/S-video	Soldering Cable+plug	7448 000 405 7448 000 505
	Audio 2 x cinch	Soldering Cable+plug	7448 000 410 7448 000 510
	Audio jack (3.5 mm stereo)	Soldering Cable+plug	7448 000 411 7448 000 511
	Volume control (Poti, cinch L/R) for Line signals e.g. of DVD players	Cable+plug	7448 000 518
	Audio XLR socket (f)	Soldering	7448 000 412
	Audio XLR plug (m)	Soldering	7448 000 416
	RS232 (9-pin SubD)	Soldering	7448 000 420

Illustration	Model	Connection	Ref. No.
	USB (A to B) (2.0 compatible)	Cable+plug	7448 000 522
	USB (B to A) (2.0 compatible)	Cable+plug	7448 000 525
	Cat 5	Gender changer	7448 000 523
	Cat 6	Cut+clamp	7448 000 423
	Cat 6	Gender changer	7448 000 526
	Cat 7 Socket "Nexans", certified up to 1000 MHz down- ward compatible to Cat 5/6	Cut+clamp	7448 000 424
	Video/audio	Soldering Cable+plug	7448 000 430 7448 000 530
	S-video/audio	Soldering Cable+plug	7448 000 431 7448 000 531
	Cat 5/audio (jack, 3.5 mm stereo)	Soldering Cable+plug	7448 000 434 7448 000 534
	VGA, video, Audio (cinch, 3.5 mm jack)	Cable+plug	7448 000 551
	VGA (HD15) fully configured 13-pin installa- tion cable	Cable+plug	7448 000 552
	DVI-D 19-pin installa- tion cable	Cable+plug	7448 000 560
	HDMI 19-pin installa- tion cable	Cable+plug	7448 000 561



## EVOLINE DESKTOP CONNECTIONS

Illustration	Model	Specification	Ref. No.
<b>Module</b>			
	<b>Evoline Tower</b>	For desktops max. 50 mm thick, ø drill-hole 102 mm, Pre-mounted with: 2 x CAT6 (Gender changer), 2 x mains mounted at 60° angle, 1 x VGA, 1 x audio (jack), each with 3 m cable and plug, lid and casing silver.	<b>7443 000 003</b>
	<b>Evoline Tower empty casing</b>	For desktops max. 50 mm thick, ø drill-hole 102 mm, lid and casing silver. Empty casing - only available in combination with modules 7443 000 5xx.	<b>7443 000 001</b>
	<b>Evoline Tower empty casing</b>	As 7443 000 001 but with tiltable lid of polished stainless steel, 2 blue LEDs below the lid and illuminated mains switch - only available in combination with modules 7443 000 5xx.	<b>7443 000 005</b>
	<b>Evoline Desk</b>	With 2 clamps for mounting on desktops 8 - 40 mm thick, 2 x mains socket, 1 x VGA, 1 x audio (jack), 2 x CAT6 each with 3 m cable and plug.	<b>7443 000 002</b>
	<b>Evoline Desk empty casing</b>	Only available in combination with modules 7443 000 5xx.	<b>7443 000 006</b>



## Clamps for Evoline Desk

Model	Specification	Ref. No.
1 clamp for mounting 7443 000 006 on a desktop	8 – 40 mm thick	7443 000 020
1 clamp for mounting 7443 000 006 on a desktop	40 – 75 mm thick	7443 000 021
2 clamps for mounting 7443 000 006 on a desktop	8 – 40 mm thick	7443 000 022
2 clamps for mounting 7443 000 006 on a desktop	40 – 75 mm thick	7443 000 023

## Mains switch and socket for Evoline

Model	Specification	Ref. No.
On/off switch	Illuminated, only available pre-mounted	7443 000 101
Mains socket Germany/Austria	50 mm, mounted at 60° angle, only available pre-mounted	7443 000 200
Mains socket Switzerland, 10 A	50 mm, mounted at 60° angle, only available pre-mounted	7443 000 199
Installation space 25 mm	For later installation of AV and network interfaces For controlling selectors etc.	7443 000 102
Installation space 50 mm		7443 000 103
Installation space 75 mm		7443 000 104
Installation space 100 mm		7443 000 105
Push-button - 1-fold 25 mm		7443 000 225

## Modules for Evoline desktop connections

All modules equipped with 3 m cable and plug (f / m).

Model	Width	Ref. No.	Width	Ref. No.
<b>Adapter plate</b>	<b>for Evoline Desk</b>		<b>for Evoline Tower side outlet</b>	
 VGA (HD15)	25 mm	7443 000 201	50 mm	7443 000 501
 DVI-D	25 mm	7443 000 202	50 mm	7443 000 502
 HDMI	25 mm	7443 000 240	50 mm	7443 000 540
 S-VIDEO VIDEO Video (cinch)	25 mm	7443 000 203	50 mm	7443 000 503
 S-VIDEO VIDEO S-video (4-pin MiniDIN)	25 mm	7443 000 204	50 mm	7443 000 504
 S-VIDEO VIDEO Video/S-video (cinch/4-pin MiniDIN)	25 mm	7443 000 205	50 mm	7443 000 505
 AUDIO L R Audio (2 x cinch)	25 mm	7443 000 210	50 mm	7443 000 510
 AUDIO 1 2 Audio (3.5 mm jack)	25 mm	7443 000 211	50 mm	7443 000 511
 XLR (3-pin)	50 mm	7443 000 212	75 mm	7443 000 512
 USB (A) (2.0 comp.)	25 mm	7443 000 222	50 mm	7443 000 522
 Cat5 (RJ45) 1 x (Evoline Desk) Cat5 (RJ45) 2 x (Evoline Tower)	25 mm	7443 000 227	50 mm	7443 000 523
 Cat6 (RJ45) 1 x (Evoline Desk) Cat6 (RJ45) 2 x (Evoline Tower)	25 mm	7443 000 226	50 mm	7443 000 524

# FLOOR CHANNELS

## Perfect cable protection

### Aluminium floor channel

- Easy access through detachable upper part
- Separate cable guidance for mains and data cables
- Anodized aluminium
- Length 200 cm (1.8 x 12.4 cm)
- 4 channels for cables with max. 8 x 3 x 1.5 mm<sup>2</sup>

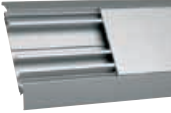
Illustration	Model	Length	Ref. No.
	Aluminium floor channel	2 m	7443 000 400
		6-pack: 6 x 2 m	7443 000 401

### Evoline Bridge

- Sturdy aluminium profile, well-designed
- Incl. decor stripe
- Separate channels for mains and data
- To be screwed or glued to all floors

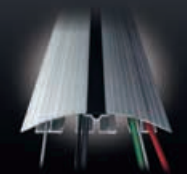
Illustration	Model	Length	Ref. No.
	Evoline Bridge	120 cm (with 4 cable clips)	7443 000 410
		160 cm (with 8 cable clips)	7443 000 411
		200 cm (with 8 cable clips)	7443 000 412



### Cable snakes

- Three separate channels
- Installation without tools (zip fastener principle)
- Tread protection up to 75 kg
- 53 x 23 mm
- Length: extended ca. 100 cm, compressed ca. 72 cm

Illustration	Model	Specification	Ref. No.
	Cable snake Classic	Light grey	7443 000 300
	Easy Fix	Light grey – element with fixing holes, e.g. to be attached to the floor	7443 000 301
	Easy Fix90-S	Mounting plate for vertical fixing of the cable snake, e.g. under the desk. Steel, black varnish	7443 000 304
	Easy Clip	Adapter for all common underfloor boxes. Colour: black	7443 000 303
	Easy Stop	Tension control	7443 000 305

### Cable chain

- Easy opening through clip mechanism
- 2 channels for separate cable guidance of mains and data cables
- Flexible in all directions, or for solid connections
- Protects LWL and copper cables against overbending
- For cables: 16 x 3 x 1.5 mm<sup>2</sup>

Illustration	Model	Specification	Ref.N o.
	Cable chain set (RAL 7035)	Consisting of cable chain 0.8 m, floor mounting kit and adapter with tension control	8733 000 000
	Cable chain set (RAL 7021)		8733 000 001
	Cable chain (RAL 7035)	1 m	8733 000 002
	Cable chain (RAL 7021)	1 m	8733 000 003
	Adapter (RAL 7035)	For mounting on ceiling, floor or desk, with tension control	8733 000 100
	Floor cover (RAL 7035)	Two-fold cover with link between cable chain and aluminium floor channel, in combination with floor mounting of 8733 000 000/ - 001	8733 000 102
	Floor cover (RAL 7021)		8733 000 103

## INSTALLATION CABLES 13/19-PIN

Easy to insert into empty conduits, no time-consuming soldering of VGA, HDMI or DVI

- Small diameter of only 16 resp. 18 mm
- Combines up to 3 different types of signals in only one cable
- Suitable for empty conduits according to EN 32
- Adapter cable available either with plug, socket or adapter plates
- 3 m connecting cables (m/f) available for the installation in desktop CablePorts (7484 000 003)
- Patented system

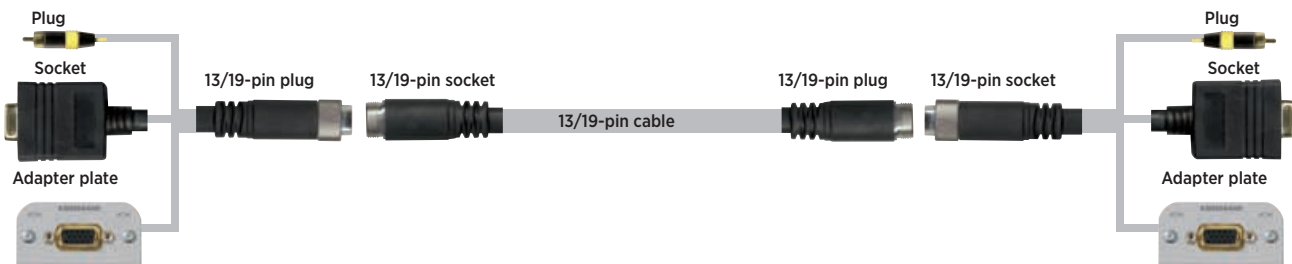

### Installation cap

Illustration	Model	Specification	Ref. No.
	Installation cap	for 13-pin	7484 000 100
		for 19-pin	7487 000 100

### On-wall socket

Illustration	Model	Specification	Ref. No.
	On-wall socket, 1-gang	Busch-Jaeger reflex SI white, incl. pre-cut cable outlet, especially for 13-pin cables when using adapter plates 7441000 554 and -555 with 90°	7441 000 009

### Gender changer





Illustration	Model	Specification	Ref. No.
	Gender changer, 13-pin f / f	Adapter coupling	7484 000 110

### Installation cables DIN 13-pin - analogue







Colour black, coating PVC, outer diameter: cable 12 mm, socket 18 mm, multi-core cable (6 x coax AWG26 + 1 x audio pair, protected AWG22, fully protected), gilded contacts. - \*For optimum quality we recommend the use of a VGA amplifier ( see page 116 / 117 )

Illustration	Model	Length	Ref. No.
	13-pin f / f	5 m	7484 000 005
		10 m	7484 000 010
		15 m*	7484 000 015
		20 m*	7484 000 020
		25 m*	7484 000 025
		30 m*	7484 000 030
	13-pin m / f	3 m	7484 000 039

## Adapter cables 13-pin plug (m)

Illustration	Model	Specification	Length	Ref.N o.
	<b>13-pin plug o</b> • VGA (HD15) • S-video (4-pin MiniDIN) • Video (cinch)	all m	35 cm	7484 000 101
		all f	35 cm	7484 000 102
	<b>13-pin plug o</b> • VGA (HD15) • Video (cinch) • Audio (3.5 mm jack)	all m	35 cm	7484 000 103
		all f	35 cm	7484 000 104
	<b>13-pin plug o</b> • VGA (HD15) fully configured	m	35 cm	7484 000 105
		f	35 cm	7484 000 106
	<b>13-pin plug o</b> • VGA (HD15) • Video (cinch) • 3 x wire e.g. for RS 232 control or IR transmission of Pixie	all m	35 cm	7484 000 107

## Adapter plates with cable and plug for installation cables 13-pin

Illustration	Model	Specification	Length	Ref.N o.
	<b>13-pin plug o</b> • VGA (HD15) • S-video (4-pin MiniDIN) • Video (cinch)	all f, consisting of 2 half plates 54 x 54 mm, required installation depth: 47 mm	35c m	7441 000 550
		all f, consisting of 2 half plates 50 x 50 mm, required installation depth: 47 mm	35c m	7444 000 550
	<b>13-pin plug to</b> • VGA (HD15) • Video (cinch) • Audio (3.5 mm jack)	all f, consisting of 2 half plates 54 x 54 mm, required installation depth: 47 mm	35c m	7441 000 551
		all f, consisting of 2 half plates 50 x 50 mm, required installation depth: 47 mm	35c m	7444 000 551
	<b>13-pin plug o</b> • VGA (HD15) fully configured	f, 1 x half plate 54 x 54 mm, required installation depth: 67 mm	35c m	7441 000 552
		f, 1 x half plate 50 x 50 mm, required installation depth: 67 mm	35c m	7444 000 552
	<b>13-pin plug o</b> • VGA (HD15) • Video (cinch) • 3 x wire e.g. for RS 232 control or IR transmission of Pixie incl. 3-pin clamp	all f, consisting of 2 half plates 54 x 54 mm, required installation depth: 47 mm	35c m	7441 000 553
		all f, consisting of 2 half plates 50 x 50 mm, required installation depth: 47 mm	35c m	7444 000 553
	<b>13-pin plug, 90° version to</b> • VGA (HD15), fully configured	VGA socket (f), consisting of 1 half plate 54 x 54 mm required installation depth: 40 mm		7441 000 554
		VGA socket (f), consisting of 1 half plate 50 x 50 mm required installation depth: 40 mm		7444 000 554
	<b>13-pin plug, 90° version to</b> • VGA (HD15) • S-video (4-pin MiniDIN) • Video (cinch)	all f, consisting of 2 half plates 50 x 50 mm, required installation depth: 40 mm		7441 000 555
		all f, consisting of 2 half plates 54 x 54 mm, required installation depth: 40 mm		7444 000 555

## Installation cables DIN 19-pin – digital

Colour black, coating PVC, outer diameter: cable 7.3 mm, socket 16 mm, Single Link HDMI/DVI-cable (AWG28/AWG24, fully protected), gilded/silver contacts. \*We recommend the use of a HDMI extender No. 5778 000 014 if using cables of more than 10 m.

Illustration	Model	Length	Ref.N o.
	<b>19-pin f / f</b>	5 m	7487 000 005
		10 m	7487 000 010
		15 m*	7487 000 015
		20 m*	7487 000 020
	<b>19-pin m / f</b>	3 m	7487 000 003



## Adapter cables 19-pin plug (m)

Illustration	Model	Length	Ref. No.
	19-pin plug to DVI-D plug (m)	35 cm	7487 000 101
	19-pin plug to DVI-D socket (f)	35 cm	7487 000 102
	19-pin plug to HDMI plug (m)	35 cm	7487 000 103
	19-pin plug to HDMI socket (f)	35 cm	7487 000 104

## Adapter plates with cable and plug for installation cables 19-pin

Please pay attention to the quality of the supply cable. We recommend to use cables of not more than 2 m length!

Illustration	Model	Specification	Length	Ref. No.
	DVI socket (f)	Half plate 54 x 54 mm, Required installation depth: 67 mm	35 cm	7441 000 560
		Half plate 50 x 50 mm Required installation depth: 67 mm	35 cm	7444 000 560
	HDMI socket (f)	Half plate 54 x 54 mm Required installation depth: 67 mm	35 cm	7441 000 561
		Half plate 50 x 50 mm Required installation depth: 67 mm	35 cm	7444 000 561

## KINDERMANN MEDIAROLLER 30

Ideal for:

- The temporary use during events
- In combination with mobile units
- In case of emergency, e.g. failure of permanent installations





The MediaRoller makes the active transmission of analogue pictures, audio and digital control signals possible up to a distance of 30 m.

Supplied with adapter cables for transmitting VGA, video, S-video, stereo audio or control signals.

Illustration	Model	Specification	Length	Ref. No.
	MediaRoller 30	<p>Cable drum with integrated VGA amplifier, switcher for mode and the following connections:</p> <ul style="list-style-type: none"> <li>• VGA without DDC (via built-in amplifier)</li> <li>• Composite video</li> <li>• Selectable: <ul style="list-style-type: none"> <li>S-video or RS232 (9-pin) linear, bi-directional, crossed bi-directional or audio stereo via 3.5 mm jack</li> </ul> </li> </ul>	30 m multicore cable	7497 000 030

## VGA cables

- High-quality VGA cable, black with gilded contacts, double protected
- Multi-coaxial cable with low resistance, double protected
- Gilded contacts
- Full pin usage (except pin 9)
- \* For optimum picture quality we recommend the use of a VGA signal amplifier.

Illustration	Model	Connection	Length	Ref.N o.
	VGA cable HD 15	m / m	1 m	7483 000 001
			2 m	7483 000 002
			5 m	7483 000 005
			10 m	7483 000 010
			15 m *	7483 000 015
			20 m *	7483 000 020
			25 m *	7483 000 025
			30 m *	7483 000 030
	VGA cable HD 15	m / f	2 m	6326 000 002
			5 m	6326 000 005
			10 m	6326 000 010
			15 m *	6326 000 015
			20 m *	6326 000 020

## High-quality VGA cables

Due to gilded contacts, a big diameter of the RGBHV coax wires (AWG25, fix) and double protection greater cable lengths resp. higher resolutions are possible than with the standard cables.



- Massive full metal casing
- Full pin usage (except pin 9)
- PVC coating, black
- Flame retardant
- Resistance (db / 100 m):  
100 MHz: 13.6  
200 MHz: 18.9  
400 MHz: 29.7

	XGA	WXGA	SXGA+	UXGA / 1080p
20 m	+++	+++	++	++
25 m	+++	+++	++	++
30 m	+++	++	++	+
40 m	+++	++	+	+

- For optimum picture quality we recommend the use of a VGA signal amplifier.

Illustration	Model	Connection	Length	Ref.N o.
	High-quality VGA cable HD 15	m / m	10 m	7496 000 110
			15 m	7496 000 115
			20 m	7496 000 120
			25 m	7496 000 125
			30 m	7496 000 130
			40 m	7496 000 140

## Special VGA cables

Illustration	Model	Connection	Length	Ref.N o.
	VGA cable HD 15 halogen free / flame-retardant	m / m	5 m	7496 000 005
			10 m	7496 000 010
			15 m *	7496 000 015
			20 m *	7496 000 020
			25 m *	7496 000 025
	VGA cable HD 15 with 90° plug on one side	m / m	2 m	7483 000 102
			5 m	7483 000 105
			10 m	7483 000 110
			15 m *	7483 000 115
			20 m *	7483 000 120

## VGA - BNC cables

Illustration	Model	Connection	Length	Ref.N o.
	VGA to BNC-5 cable HD 15 to 5 x BNC plug, multi protected with iron core, low resistance	m / m	2 m	6328 000 001
			5 m	5751 000 000
			10 m	5752 000 001
			20 m	5754 000 002

## DVI cables

- High-quality DVI cables, black with gilded contacts, double protected, for best picture quality
- For digital (DVI-D) or digital and analogue (DVI-I) transmission
- Dual link
- \*We recommend to use the DVI repeater No. 5778 000 017 for cable lengths > 10 m.

Illustration	Model	Connection	Length	Ref. No.
	DVI-D cable 24 + 1-pin	m / m	2 m	5809 000 000
			5 m	5809 000 002
			10 m	5809 000 003
			15 m *	5809 000 004
			DVI-I cable 24 + 5-pin	m / m
		5 m	5809 000 031	
		10 m *	5809 000 032	

## High-quality HDMI cables

- HDMI cables, black with gilded contacts, double protected, for best picture quality
- HDMI 1.4 compatible, incl. Ethernet channel / 15 m cable HDMI 1.3 without Ethernet channel
- For digital transmission of video and audio; supports HDTV and HDCP
- \*We recommend to use the HDMI repeater No. 5778 000 014 for cable lengths > 10 m.

Illustration	Model	Connection	Length	Ref. No.
	HDMI cable, type A, 19-pin	m / m	2 m	5809 000 102
			5 m	5809 000 105
			10 m	5809 000 110
			15 m *	5809 000 013



## Active HDMI cables with integrated signal amplifier

The active HDMI cables are equipped with a plug with integrated amplifier (plug on the side of the display/projector).





- Optimized for digital HDTV signals up to 1080p
- Transmits all digital audio formats, e.g. 7.1, DTS®-HD Master Audio, Dolby® TrueHD, etc.
- Transmission rate: up to 340 MHz (10.2 Gigabit/s)
- Version 1.3c / 1.4 with deep color and x.v.Color™
- Transmits all data of the HDMI protocol, e.g. CEC, HDCP and EDID
- Cable: High-purity tin-coated OFC copper wires
- Protection: three-fold (2 x foil + tin-coated copper braid)

Illustration	Model	Connection	Length	Ref. No.
	Active HDMI cable, type A, 19-pin	m / m	15 m	5809 000 035
			20 m	5809 000 036
			30 m	5809 000 037
			40 m	5809 000 038



## Adapter cables

Illustration	Model	Connection	Length	Ref. No.
	DVI-A to VGA cable DVI-A (12 + 5-pin) Plug to HD 15 plug	m / m	2 m	5809 000 007
	HDMI to DVI-D DVI-I (24 + 1-pin) plug to HDMI plug	m / m	2 m	5809 000 020
	HDMI to display port cable	m / m	3 m	5809 000 024

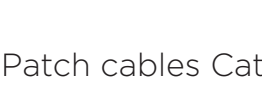

## USB cables / amplifiers

Illustration	Model	Specification	Connection	Length	Ref.N o.
	USB 2.0 cable	<ul style="list-style-type: none"> <li>• USB 1.1 compatible</li> <li>• Grey</li> </ul>	A - m / A - m	2 m	5773 000 003
				5 m	5773 000 005
	USB 2.0 cable	<ul style="list-style-type: none"> <li>• USB 1.1 compatible</li> <li>• Grey</li> </ul>	A - m / B - m	2 m	5773 000 004
				5 m	5799 000 000
	USB 2.0 active hub	<ul style="list-style-type: none"> <li>• For cable connections &gt; 5 m</li> <li>• Active USB 2.0 hub with 5 m cable</li> <li>• Can be further extended (max. 3x)</li> <li>• USB powered, power supply not necessary</li> </ul>	A - m / A - f	5 m	5771 000 000
	USB 2.0 active cable	<ul style="list-style-type: none"> <li>• USB 2.0</li> <li>• Integrated signal repeater</li> <li>• Cannot be extended</li> </ul>	A - m / B - m	10 m	5771 000 001
	USB 1.1 extender	<ul style="list-style-type: none"> <li>• Transmits USB signals via CAT 5 cable up to 45 m length</li> <li>• USB 1.1</li> <li>• USB powered, power supply not necessary</li> </ul>			5772 000 001

## Patch cables Cat5 and Cat6

Illustration	Model	Specification	Connection	Length	Ref.N o.
	Cat5 UTP cable for use in combination with Kindermann Quickselect S / R	<ul style="list-style-type: none"> <li>• 1 : 1 connected</li> <li>• UTP, not protected</li> <li>• 4 x 2 x AWG 264</li> <li>• Green</li> </ul>	RJ 45 m / m	0.5 m	5772 000 020
				1 m	5772 000 021
				2 m	5772 000 022
				5 m	5772 000 023
				10 m	5772 000 024
				15 m	5772 000 025
				20 m	5772 000 026
				25 m	5772 000 027
	Cat5 patch cable	<ul style="list-style-type: none"> <li>• 1 : 1, S-FTP, protected</li> <li>• 4 x 2 x AWG 26</li> <li>• Indication of length on plug</li> <li>• Grey</li> </ul>	RJ 45 m / m	1 m	5772 000 008
				2 m	5772 000 010
				5 m	5772 000 009
				10 m	5772 000 011
				15 m	5772 000 012
				20 m	5772 000 013
				25 m	5772 000 014
	Cat6 patch cable	<ul style="list-style-type: none"> <li>• 1 : 1, S-STP</li> <li>• Fully protected</li> <li>• 4 x 2 x AWG 26</li> <li>• Indication of length on plug</li> <li>• Grey</li> </ul>	RJ 45 m / m	1 m	5772 000 101
				2 m	5772 000 102
				5 m	5772 000 105
				10 m	5772 000 110
				15 m	5772 000 115
				20 m	5772 000 120
				25 m	5772 000 125
30 m	5772 000 130				

## RS 232 / serial cables

Illustration	Model	Specification	Connection	Length	Ref.N o.
	RS 232 cable	<ul style="list-style-type: none"> <li>• 9-pin SubD</li> <li>• 1 : 1, protected</li> </ul>	f / m	2 m	5825 000 002
				5 m	5825 000 003
				10 m	5825 000 000
				15 m	5825 000 001
				20 m	5826 000 000
	Zero modem cable	<ul style="list-style-type: none"> <li>• 9-pin SubD</li> <li>• Wiring: 1+6-4, 2-3, 3-2, 4-1+6, 5+5, 7-8, 8-7 protected</li> </ul>	f / m	2 m	5826 000 002
				5 m	5826 000 005
				10 m	5826 000 010



## Composite video cables without sound

Illustration	Model	Specification	Connection	Length	Ref. No.
	Composite video cable (cinch)	<ul style="list-style-type: none"> <li>• Double protected</li> <li>• Gilded plugs</li> <li>• 75 Ω, for digital equipment</li> </ul>	m / m	2 m	5837 000 001
				5 m	5837 000 002
				10 m	5837 000 000
				15 m	5838 000 001
				20 m	5839 000 001
				25 m	5839 000 004
				30 m	5839 000 005



## Composite video cables with sound

Illustration	Model	Specification	Connection	Length	Ref. No.
	AV cable (3 x cinch)	<ul style="list-style-type: none"> <li>• Double protected</li> <li>• 1 connection for video (75 Ω)</li> <li>• 2 connection for audio</li> <li>• Gilded plugs, colour codex</li> <li>• For digital equipment</li> </ul>	m / m	2 m	6415 000 001
				5 m	6415 000 002
				10 m	6415 000 003
				15 m	6414 000 001
				20 m	6416 000 001
				25 m	6416 000 002

## S-video cables without sound

Illustration	Model	Specification	Connection	Length	Ref. No.
	S-video cable (4-pin MiniDIN)	<ul style="list-style-type: none"> <li>• Double protected</li> <li>• 2 coax wires (75 Ω)</li> <li>• Gilded plugs</li> </ul>	m / m	2 m	7482 000 000
				5 m	7482 000 001
				10 m	5830 000 000
				15 m	5831 000 000
				20 m	5832 000 001
				25 m	5832 000 004
				30 m	5832 000 005

## Component video cables

Illustration	Model	Specification	Connection	Length	Ref. No.
	Component video cable (3 x cinch)	<ul style="list-style-type: none"> <li>• Double protected</li> <li>• 3 coax wires (75 Ω)</li> <li>• Gilded plugs, colour codex</li> </ul>	m / m	2 m	5569 000 005
				5 m	5569 000 002
				10 m	5569 000 003
				15 m	5569 000 004
				20 m	5569 000 006
	VGA to 3 x cinch	<ul style="list-style-type: none"> <li>• E. g. for projectors with component video input via VGA</li> </ul>	m / m	2 m	5569 000 000

## Speakon loudspeaker cables

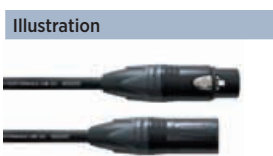
Illustration	Model	Specification	Connection	Length	Ref. No.	
	Speakon 4-pin - 2 wires		m / m	5 m	7489 000 020	
				10 m	7489 000 021	
				15 m	7489 000 022	
				20 m	7489 000 023	
	Speakon 4-pin - 4 wires			m / m	5 m	7489 000 025
					10 m	7489 000 026
					15 m	7489 000 027
					20 m	7489 000 028

## Microphone cables

Illustration	Model	Specification	Connection	Length	Ref.N o.
	XLR 3 pin	<ul style="list-style-type: none"> <li>Professional microphone cable</li> <li>With Neutrik® metal XLR plug connections</li> <li>Core diameter: 0.22 mm<sup>2</sup></li> </ul>	m / f	1.5 m	7489 000 000
				2.5 m	7489 000 001
				5 m	7489 000 002
				10 m	7489 000 003
				20 m	7489 000 004

## Audio cables

Illustration	Model	Specification	Connection	Length	Ref.N o.
	Stereo cinch		m / m	2 m	5762 000 001
				5 m	5762 000 000
				10 m	5763 000 000
	Stereo cinch	<ul style="list-style-type: none"> <li>High-quality version</li> <li>Double protected</li> <li>2 coax connections</li> <li>Gilded plugs, colour codes</li> </ul>	m / m	10 m	5763 000 001
				15 m	5764 000 000
				20 m	5765 000 000
	Stereo jack 3.5 mm		m / m	1.5 m	5766 000 003
				2.5 m	5766 000 002
				5 m	5766 000 001
				10 m	5767 000 001
	Stereo jack 3.5 mm	<ul style="list-style-type: none"> <li>High-quality version</li> <li>Fully protected</li> <li>Gilded plugs</li> </ul>	m / m	10 m	5766 000 004
				15 m	5766 000 005
				20 m	5766 000 006
	Stereo cinch to 3.5 mm jack		m / m	2 m	5854 000 001







## Gender changer / adapter

Gender changers change f plugs into m plugs and vice versa

Illustration	Model	Specification	Connection	Ref.N o.	
	Gender changer VGA HD15		f / f	6418 000 000	
	Gender changer VGA HD15		m / m	6418 000 001	
	Adapter cable VGA to BNC5		f / f	6281 49	
	Adapter cinch / BNC		m / f	6419 000 000	
	Adapter BNC / cinch		m / f	6419 000 001	
	Gender changer 3 x cinch		f / f	6418 000 002	
	Gender changer S-video		f / f	6418 000 003	
	Video / S-video adapter	Converts signals in both directions, e.g. for connecting a VHS recorder to an S-video input or a cinch socket to a S-video socket			5853 000 000
	Scartc inchad apter	With output video + S-video + sound	selectable in / out		6288 000 001

## Gender changer/adapter

Gender changers change f plugs into m plugs and vice versa

Illustration	Model	Specification	Connection	Ref. No.
	Adapter cinch / jack	3.5 mm jack to 2 x cinch	f / m	5854 000 000
	Adapter DVI-A to VGA	DVI-A (12 + 5 pin) plug to HD15 socket	m / f	5809 000 006
	Adapter HDMI to DVI-D		f / m	5809 000 021
	Adapter HDMI to DVI-D		m / f	5809 000 023
	Adapter USB		A - m / B - f	5577 000 000
	Adapter HDMI to display port		m / f	5809 000 025

## Plug connectors

Illustration	Model	Specification	Ref. No.
	VGA plug HD15 SubD VGA socket HD15 SubD	<ul style="list-style-type: none"> <li>Gilded contacts, soldering version</li> <li>Metal casing with screws</li> <li>Incl. 5 different cable bushings</li> </ul>	7489 000 200 7489 000 201
	BNC plug for RG59 (AWG 20) BNC socket for RG59 (AWG 20) BNC plug for BNC5 (AWG 26) BNC socket for BNC5 (AWG 26)	<ul style="list-style-type: none"> <li>Gilded</li> </ul>	7489 000 202 7489 000 203 7489 000 204 7489 000 205
	Crimp tong, green	<ul style="list-style-type: none"> <li><b>Suitable for the plugs:</b> 0.041, 0.068, 0.178, 0.278, 0.255"</li> <li>1.07, 1.73, 4.52, 7.06, 6.48 mm</li> <li><b>Suitable for the cables:</b> RG59, 62, 174</li> </ul>	7489 000 300
	DVI-D plug (18+1-pin) DVI-D socket (24+1-pin)	<ul style="list-style-type: none"> <li>Gilded contacts, soldering version</li> <li>Plastic housing with metal protection</li> </ul>	7489 000 206 7489 000 207
	S-video plug (4-pin MiniDIN) S-video socket (4-pin MiniDIN)	<ul style="list-style-type: none"> <li>Gilded contacts</li> <li>Metal housing</li> </ul>	7489 000 208 7489 000 209
	Cinch plug (yellow) Cinch socket (yellow) Cinch plug set (red & white) Cinch socket set (red & white) Cinch plug set (red & green & blue) Cinch socket set (red & green & blue)	<ul style="list-style-type: none"> <li>Gilded contacts</li> <li>Metal housing</li> </ul>	7489 000 210 7489 000 211 7489 000 212 7489 000 213 7489 000 214 7489 000 215
	Jack plug (3.5 mm) Jack socket (3.5 mm)	<ul style="list-style-type: none"> <li>High-quality metal version</li> <li>Gilded contacts</li> </ul>	7489 000 216 7489 000 217
	XLR plug 3-pin XLR socket 3-pin	<ul style="list-style-type: none"> <li>High-quality metal version</li> <li>Neutrik®</li> </ul>	7489 000 218 7489 000 219
	Speakon plug 4-pin	<ul style="list-style-type: none"> <li>For cables of diameter: 6 - 14 mm</li> <li>Neutrik®</li> </ul>	7489 000 220

## AV cables – by the meter or roll

Specification	Model	Specification	Ref.N o.	
	High-qualityV GA cable	<ul style="list-style-type: none"> <li>• 5 x coax AWG 25/75 Ω</li> <li>• 4 x wire AWG 22</li> <li>• Double protected</li> <li>• Flame-retardant PVC coating, black</li> </ul>	<ul style="list-style-type: none"> <li>• Attenuation (db/100 m)</li> <li>• 100 MHz: 13.6</li> <li>• 200 MHz: 18.9</li> <li>• 400 MHz: 29.7</li> <li>• Outer diameter: 10 mm</li> </ul>	7489 000 040
	RGBHVc able	<ul style="list-style-type: none"> <li>• 5 x coax AWG 26/75 Ohm</li> <li>• Fully protected</li> <li>• Flame-retardant PVC coating, black</li> <li>• Outer diameter: 9 mm</li> </ul>	<ul style="list-style-type: none"> <li>• Attenuation (db/100 m)</li> <li>100 MHz: 17.2</li> <li>200 MHz: 24.3</li> <li>400 MHz: 38.0</li> </ul>	7489 000 050
	DVI-Dc able	<ul style="list-style-type: none"> <li>• Component A, B, D: AWG28</li> <li>• Component C: AWG24</li> <li>• Double protected</li> </ul>	<ul style="list-style-type: none"> <li>• For single link</li> <li>• Flame retardant PVC coating, black</li> <li>• Outer diameter: 9 mm</li> </ul>	7489 000 060
	S-video cable	<ul style="list-style-type: none"> <li>• 2 x coax AWG 26/75 Ω</li> <li>• Double protected</li> <li>• Flame-retardant PVC coating, black</li> </ul>	<ul style="list-style-type: none"> <li>• Attenuation (db/100 m)</li> <li>100 MHz: 17.2</li> <li>• Outer diameter: 7.4 mm</li> </ul>	7489 000 070
	Video cable (RG59)	<ul style="list-style-type: none"> <li>• Coax AWG 20/75 Ω</li> <li>• Double protected</li> <li>• Flame-retardant PVC coating, black</li> <li>• Outer diameter: 6 mm</li> </ul>	<ul style="list-style-type: none"> <li>• Attenuation (db/100 m)</li> <li>10 MHz: 2.8</li> <li>135 MHz: 9.0</li> <li>270 MHz: 12.5</li> <li>360 MHz: 14.6</li> </ul>	7489 000 080
	AVc cable	<ul style="list-style-type: none"> <li>• 3 x coax AWG 22/75 Ω</li> <li>• Double protected</li> <li>• PVC coating, black</li> <li>• Outer diameter: 3 x 6 mm</li> </ul>	<ul style="list-style-type: none"> <li>• Attenuation (db/100 m)</li> <li>10 MHz: 3.0</li> <li>100 MHz: 13.1</li> </ul>	7489 000 090
	Stereo audio cable (cinch)	<ul style="list-style-type: none"> <li>• 2 x coax AWG 22/75 Ω</li> <li>• Double protected</li> <li>• PVC coating, black</li> <li>• Outer diameter: 2 x 6 mm</li> </ul>	<ul style="list-style-type: none"> <li>• Attenuation (db/100 m)</li> <li>10 MHz: 3.0</li> <li>100 MHz: 13.1</li> </ul>	7489 000 100
	Stereo audio cable (jack)	<ul style="list-style-type: none"> <li>• AWG 26/75 Ω</li> <li>• Fully protected</li> </ul>	<ul style="list-style-type: none"> <li>• Flame-retardant PVC coating, black</li> <li>• Outer diameter: 4 mm</li> </ul>	7489 000 110
	Loudspeaker cable 2 x 1.5 mm <sup>2</sup>	<ul style="list-style-type: none"> <li>• 2 cores, twisted, highly flexible, plastic coating</li> <li>• Wiring: 84 x 0.15 mm, copper (1.5 mm<sup>2</sup>)</li> </ul>	<ul style="list-style-type: none"> <li>• Resistance: 13 Ω/km(1.5 mm<sup>2</sup>)</li> <li>• Resistance: 8 Ω/km (2.5 mm<sup>2</sup>)</li> <li>• Overall diameter: 7 mm / 8 mm</li> <li>• Colour: black</li> </ul>	7489 000 009
	Loudspeaker cable 2 x 2.5 mm <sup>2</sup>	<ul style="list-style-type: none"> <li>• Wiring: 140 x 0.15 mm, copper (2.5 mm<sup>2</sup>)</li> </ul>		7489 000 010
	Microphone cable	<ul style="list-style-type: none"> <li>• Wiring 2 x 28 x 0.1 mm<sup>2</sup></li> <li>• Protected</li> </ul>	<ul style="list-style-type: none"> <li>• Colour: black</li> <li>• Outer diameter: 5 mm</li> </ul>	7489 000 030



# QUICKSELECT

## The flexible presentation interface

The Kindermann QuickSelect is the ideal solution for all rooms, that require a flexible seating in combination with media technology interfaces at the conference tables.

The intelligent electronics harbours mains, network, VGA and audio in only one casing. The QuickSelect units are connected in a line with four cables each. This makes an extra wiring between each unit and the next floor box or wall channel a thing of the past, which would be an eyesore and could make people trip.

QuickSelect allows every participant to connect his notebook to a desk cable port and then via mouse click to the projector. Moreover, the unit can be operated centrally via a panel or a media control.



### Features:

- Table to table connections in a line - avoiding a mass of wires and preventing people from stumbling
- Modular system, extendable number of participants up to 16 in a line and up to 120 m of total cable length (depending on resolution)
- Each QuickSelect/S can be connected to mains, network, VGA and audio.
- Incl. bracket for mounting under the desktop
- Height only 4 cm
- Centralized operation via panel or media control
- Transmission of audio and VGA signals via inexpensive CAT5-UTP cable
- Reliable and sturdy due to integrated power supply and metal casing

## Example of the flexible layout of tables

Arrangement in U shape

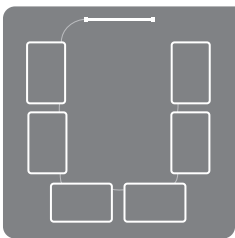

Arrangement in D shape

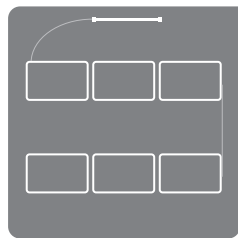

Arrangement in I shape

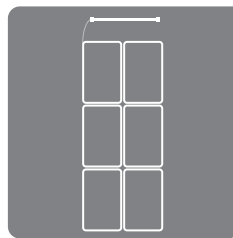

## Connection plan

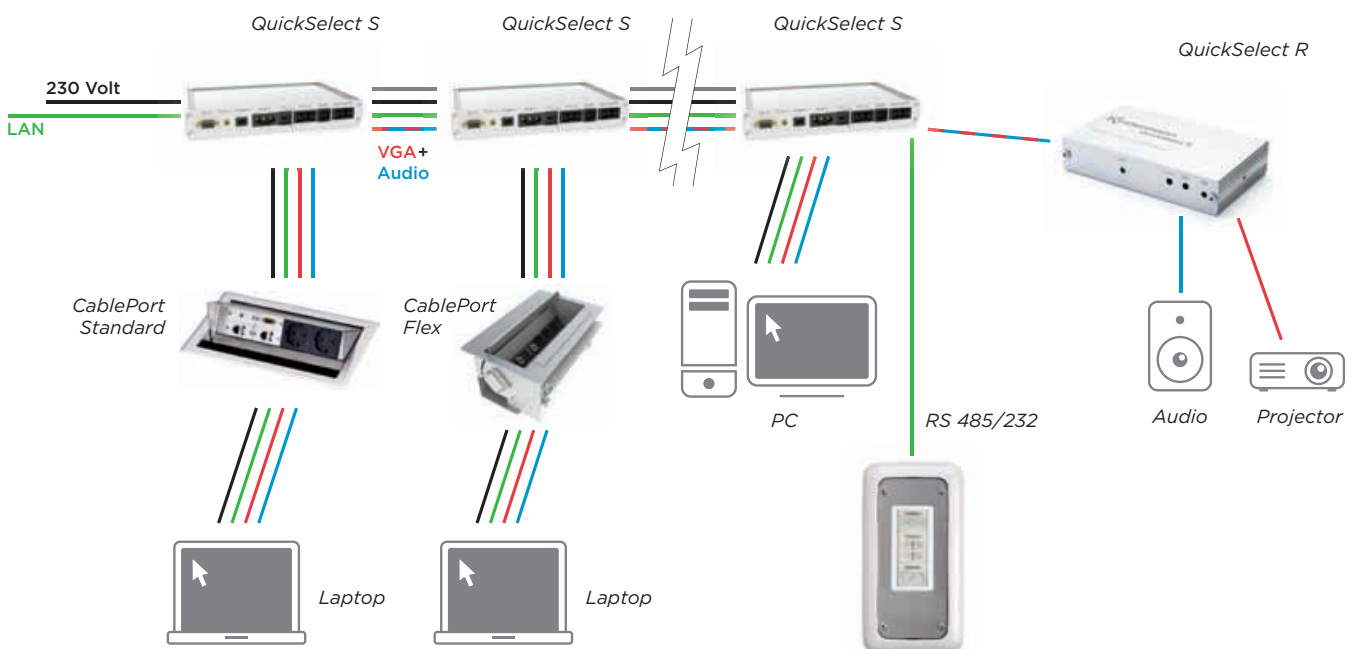



### QuickSelect S

- Max. resolution up to UXGA (1600 x 1200)/60 Hz
- Input: VGA HD15 (f), audio stereo jack 3.5 mm (f)
- Integrated 5-fold 10/100 MBit network switch
- RJ11 socket for external push button with feedback (connection cable supplied)
- 1 x Wieland GST18 plug (mains input)
- 1 x Wieland GST18 socket (mains output to CablePort)
- 1 x Wieland GST18 socket (mains output to next QuickSelect)
- 1 x Wieland EST2i3 plug (control bus input)
- 1 x Wieland EST2i3 socket (control bus output)
- 1 x RJ45 socket (input VGA/audio to next QuickSelect)
- 1 x RJ45 socket (output VGA/audio from previous QuickSelect)
- 2 x switches for choosing the bus address (256 addresses)
- Dimensions: 260/293 x 179 x 42 mm (width with and without mounting bracket)

<b>QuickSelectS</b>	<b>7447 000 000</b>
---------------------	---------------------



### QuickSelect R

Transforms the VGA and audio signals converted by the QuickSelect S for the transmission via network cable back into standard VGA and audio signals

- Input: RJ45 socket
- Output: VGA HD15 (f), audio jack 3.5 mm (f)
- Level control - amplifier and equalizer
- Voltage supply via QuickSelect S or external power supply
- Dimensions: 12 cm x 7.5 cm x 2.5 cm

<b>QuickSelectR</b>	<b>7447 000 100</b>
---------------------	---------------------



### RS485/232 converter

Bi-directional format converter between RS 232, RS 485 and RS 422 protocols, for operating the QuickSelect e.g. via a media control

- Ports - RS 232, RS 485, and RS 422
- Format converter - each command is converted in the other formats with the same baud rate.
- RS 485 - up to 32 units can be connected via RS 485.
- Baud rates - 1200, 2400, 9600, 19200 and 38400
- Dimensions: 12 cm x 7.5 cm x 2.5 cm

<b>RS485 / 232c onverter</b>	<b>7447 000 110</b>
------------------------------	---------------------

### Accessories - connection cables

Illustration	Model	Specification	Length	Ref.N o.
	<b>CAT5-UTP cable</b> for use with Kindermann QuickSelect S/R	<ul style="list-style-type: none"> <li>• 1 : 1 connected</li> <li>• UTP, unprotected</li> <li>• 4 x 2 x AWG 264</li> <li>• Colour: green</li> <li>• Connection: RJ 45 m / m</li> </ul>	1 m	5772 000 021
			2 m	5772 000 022
			5 m	5772 000 023
	<b>CAT6 patch cable</b>	<ul style="list-style-type: none"> <li>• 1 : 1, S-STP</li> <li>• Fully protected</li> <li>• 4 x 2 x AWG 26</li> <li>• Indication of length on plug</li> <li>• Colour: grey</li> <li>• Connection: RJ 45 m / m</li> </ul>	1 m	5772 000 101
			2 m	5772 000 102
			5 m	5772 000 105
	<b>Connection cable Schuko plug/Wieland socket GST 18</b>		1 m	7444 000 301
			2 m	7444 000 302
			3 m	7444 000 303
			5 m	7444 000 305
	<b>Wieland extension socket - plug EST2i3</b>	<ul style="list-style-type: none"> <li>• Combined net and bus cable for connecting the QuickSelect units</li> </ul>	1 m	7447 000 301
			2 m	7447 000 302
			3 m	7447 000 303
			5 m	7447 000 305

## Twisted pair signal transmission











Illustration	Model	Specification	Ref. No.
	VGA / audio extender - transmission via CAT cable	<p><b>For the transmission for computer image / VGA incl. sound via inexpensive CAT5/Cat5e or Cat6 line (recommended) over long distances.</b></p> <p>Consisting of transmitter and receiver with power supply. Switch for stereo / mono sound resp. short / long distance. Switch for brightness and focus in order to compensate cable loss resp. for optimal image quality.</p> <p><b>Range:</b> up to max. 180 m (depending on unit, cable, resolution)  <b>Band width:</b> video 350 MHz, audio 126 kHz  <b>Transmitter:</b> VGA input (HD15 m), audio input 3.5 mm jack (m), RJ45 output, power supply (5 V / 100 mA) via USB A (m) or optional power supply  <b>Dimensions:</b> 52 x 27 x 100 mm  <b>Receiver:</b> RJ45 input, VGA to (HD15p - m), 3.5 mm jack (f)  <b>Power supply:</b> 5 VDC / 450 mA (incl.)  <b>Dimensions:</b> 52 x 30 x 100 mm</p>	7488 000 030
	Power supply	5 V DC	7488 000 034
	4-fold splitter	<p><b>Input:</b> 1 x VGA - m (HD15), 1 x audio - f (3.5 mm jack)  <b>Output:</b> 4 x RJ45 - f, 1 x VGA - f (HD15), 1 x audio - f (3.5 mm jack)</p>	7488 000 031
	8-fold splitter	As 7488 000 031, but with 8 RJ45 outputs	7488 000 032
	Receiver module	When using 7488 000 031 or 7488 000 032	7488 000 033

Illustration	Model	Specification	Ref. No.
	HDMI extender - transmitter Transmission via CAT cable	<p><b>For the transmission of HDMI signals (video/computer) via twisted pair line</b></p> <ul style="list-style-type: none"> <li>• Range up to 100 m (1080i) with Cat7 line</li> <li>• HDCP and HDMI 1.3a conform</li> <li>• HDMI socket / RJ45 out</li> <li>• Metal casing 62 x 52 x 24 mm</li> <li>• 12 VDC / 250 mA power supply incl.</li> </ul>	7488 000 040
	HDMI extender - receiver Transmission via CAT cable	<p><b>Receiver for 7488 000 040</b></p> <ul style="list-style-type: none"> <li>• RJ45 in / HDMI socket out</li> <li>• No additional power supply necessary up to 50 m length</li> </ul>	7488 000 041
	DVI extender - transmitter Transmission via CAT cable	<p><b>For the transmission of DVI signals via twisted pair line</b></p> <ul style="list-style-type: none"> <li>• Range up to 100 m (SXGA) resp. 80 m (UXGA) with CAT7 line</li> <li>• Supports HDCP and EDID</li> <li>• DVI socket in / RJ45 out</li> <li>• Metal casing 62 x 52 x 24 mm</li> <li>• 12 VDC / 250 mA power supply incl.</li> </ul>	7488 000 042
	DVI extender - receiver Transmission via CAT cable	<p><b>Receiver for 7488 000 042</b></p> <ul style="list-style-type: none"> <li>• RJ45 in / DVI socket out</li> <li>• No additional power supply necessary up to 50 m length</li> <li>• Dimensions: 62 x 52 x 24 mm</li> </ul>	7488 000 043

## VGA signal amplifiers / splitters

Illustration	Model	Specification	Ref. No.
	VGA booster advanced 1 to 1	<p><b>VGA signal amplifier with adjustable cable compensation (level/EQ)</b></p> <ul style="list-style-type: none"> <li>• 1 input / 1 output (HD15 f / f)</li> <li>• Can be placed at the line end</li> <li>• Metal casing 67 x 56 x 38 mm</li> <li>• Incl. power supply, 12V DC / 600 mA</li> </ul>	5778 000 001
	VGA booster pro 1 to 1	<p><b>High-quality VGA signal amplifier with adjustable cable compensation (level/EQ)</b></p> <ul style="list-style-type: none"> <li>• 1 input / 1 output (HD15 f / f)</li> <li>• Resolution up to UXGA (1600 x 1200)</li> <li>• ID-Bit control</li> <li>• Metal casing 56 x 43 x 22 mm</li> <li>• Incl. power supply, 5V DC / 307 mA</li> </ul>	5778 000 011
	Monitor splitter basic VGA 1 to 2	<ul style="list-style-type: none"> <li>• 1 input / 2 outputs (HD15 m / f)</li> <li>• Bandwidth 250 MHz</li> <li>• Supports DDC, DDC2, DDC2B @ output 1</li> <li>• Metal casing 130 x 75 x 42 mm</li> <li>• Power supply DC 9V, 180 mA</li> <li>• Connection cable VGA 1.8 m (m / f) included in package</li> </ul>	5778 000 010
	Monitor splitter basic VGA 1 to 4	<p>As 5778 000 010 but with</p> <ul style="list-style-type: none"> <li>• 1 input / 4 outputs (HD15 m / f)</li> <li>• Power supply DC 9V, 220 mA</li> <li>• Connection cable VGA 1.8 m (m / f) included in package</li> </ul>	6298 000 002

## VGA signal amplifiers / splitters

Illustration	Model	Specification	Ref.N o.
	<b>Monitor splitter USB power VGA 1 to 2</b>	<ul style="list-style-type: none"> <li>• 1 input / 2 outputs (HD15 m / f)</li> <li>• Bandwidth 450 MHz</li> <li>• Supports up to 2048 x 1536</li> <li>• Plastic casing 70 x 72 x 25 mm</li> <li>• USB powered DC 5V – power supply via USB (A - m to A - f)</li> <li>• Connection cable VGA 15 cm, USB 40 cm</li> </ul>	5778 000 006
	<b>Monitor splitter pro VGA 1 to 2</b>	<ul style="list-style-type: none"> <li>• 1 input / 2 outputs (HD15 socket, all)</li> <li>• Bandwidth 400 MHz (-3 dB)</li> <li>• KR-ISP sync signal processing</li> <li>• ID-Bit control EDID support</li> <li>• Metal casing 121 x 72 x 25 mm</li> <li>• Power supply 5 VDC / 130 mA</li> <li>• Incl. 0.9 m VGA cable</li> </ul>	7480 000 001
	<b>Monitor splitter pro VGA 1 to 4</b>	<b>As 7480 000 001 but with</b> <ul style="list-style-type: none"> <li>• 1 input / 4 outputs (HD15 socket)</li> </ul>	7480 000 002

## VGA switchers



Illustration	Model	Specification	Ref.N o.
	<b>VGA share basic 21</b>	<ul style="list-style-type: none"> <li>• 2 inputs / 1 output (HD15 sockets)</li> <li>• 2 select buttons</li> <li>• Auto skip, for skipping non-active inputs</li> <li>• 4 status LEDs</li> </ul>	5816 000 011
	<b>VGA share basic 41</b>	<b>As 5816 000 011 but with</b> <ul style="list-style-type: none"> <li>• 4 inputs / 1 output (HD15 f)</li> <li>• 4 select buttons</li> </ul>	5816 000 012
	<b>VGA share basic 21 - remote</b>	<ul style="list-style-type: none"> <li>• 2 inputs / 1 output (HD15 f)</li> <li>• Switching via buttons or IR remote control (included in package)</li> <li>• Bandwidth 450 MHz</li> <li>• Power supply 5 VDC, 1 A</li> </ul>	5816 000 022
	<b>VGA share basic 41 - remote</b>	<b>As 5816 000 022 but with</b> <ul style="list-style-type: none"> <li>• 4 inputs / 1 output (HD15 f)</li> </ul>	5816 000 023
	<b>VGA share basic 81 - remote</b>	<ul style="list-style-type: none"> <li>• 8 inputs (HD15 m)</li> <li>• 1 output (HD15 f)</li> <li>• IR remote control for selection of sources</li> <li>• IR receiver with 1.8 m connection cable</li> <li>• Buttons on the unit: up / down for successive selection and blank</li> </ul>	5816 000 003
	<b>VGA audio share pro 21au tomatic</b>	<b>Switches automatically to second input in case of a loss of the original input signal (VGA and audio).</b> <ul style="list-style-type: none"> <li>• 2 VGA inputs / 1 output + 1 loop output (HD15 f)</li> <li>• 2 audio inputs / 1 output (3.5 mm jack - f)</li> <li>• KR-ISP technology for sync / signal processing</li> <li>• 2 LEDs show the selected input</li> </ul>	5816 000 004
	<b>VGA audio share pro 41au tomatic</b>	<b>As 5816 000 004 but with</b> <ul style="list-style-type: none"> <li>• 4 VGA inputs / 1 output + 1 loop output (HD 15 f)</li> <li>• Bandwidth 300 MHz (-3 dB)</li> <li>• Integrated signal amplifier – often makes an additional amplifier at the output superfluous</li> </ul>	5816 000 021
	<b>VGA matrix 2 x 2</b>	<b>The VGA matrix switches 2 computers to 2 displays / projectors and also functions as a signal amplifier.</b> <b>Each output shows either input 1, input 2 or blank.</b> <ul style="list-style-type: none"> <li>• 2 VGA inputs / 2 outputs (HD15 f)</li> <li>• 2 select buttons</li> <li>• 4 status LEDs</li> </ul>	5816 000 005





## Multi format switchers

Illustration	Model	Specification	Ref. No.
	<b>Presentation switcher Plus</b>	<p><b>The central control unit for smaller conference rooms</b></p> <ul style="list-style-type: none"> <li>• Combines 4 switchers in a 19" casing</li> <li>• 4 to 1 VGA, 4 to 1 video, 4 to 1 S video; for each type of signal there is a 4 to 1 audio switcher</li> <li>• Microphone input switchable for dynamic and condenser microphone</li> <li>• Talk-over function for microphone, volume control for audio source</li> </ul> <p><b>Operation:</b> Via button on the unit, IR remote control or RS 232 interface via media control, bandwidth 415 MHz (VGA), 725 MHz (S video), 683 MHz (Video) Size: 19" / 1 RU 483 x 178 x 45 mm</p> <p><b>Inputs:</b></p> <ul style="list-style-type: none"> <li>• 4 x VGA (HD 15 f)</li> <li>• 4 x S video (4-pin MiniDIN f)</li> <li>• 4 x video (cinch f)</li> <li>• 4 x audio (3.5 mm jack f) for VGA</li> <li>• 4 x audio (stereo cinch f) for video</li> <li>• 4 x audio (stereo cinch f) for S video</li> <li>• 1 x microphone (6.3 mm jack f)</li> </ul> <p><b>Outputs:</b></p> <ul style="list-style-type: none"> <li>• 1 x VGA (HD 15 f)</li> <li>• 1 x S video (4-pin MiniDIN f)</li> <li>• 1 x video (cinch f)</li> <li>• 1 x audio PC (3,5 mm jack f)</li> <li>• 1 x audio video (stereo cinch f)</li> <li>• 1 x audio S video (stereo cinch f)</li> <li>• 1 x master audio out (stereo cinch f)</li> </ul>	7485 000 006



## Video / audio switchers

Illustration	Model	Specification	Ref. No.
	<b>AV share basic 41</b>	<p><b>Selector for composite video, S video and stereo audio as well as video converter</b></p> <ul style="list-style-type: none"> <li>• 4 inputs / 1 output (4-pin MiniDIN, 3 x cinch, all f)</li> <li>• S video - composite video converter</li> <li>• Composite video - S video converter</li> <li>• Plastic casing 190 x 115 x 50 mm</li> </ul>	7481 000 000
	<b>AV selector basic 61 remote</b>	<p><b>Selector for S video, composite video (FBAS) and stereo audio with remote control</b></p> <ul style="list-style-type: none"> <li>• 6 inputs / 1 output (S video 4-pin MiniDin, 3 cinch)</li> <li>• Plastic casing</li> <li>• With built-in power supply</li> <li>• Incl. IR remote control</li> </ul>	7481 000 007

## DVI signal amplifiers / splitters

Illustration	Model	Specification	Ref. No.
	<b>DVI extender advanced 1 : 1</b>	<p><b>Extends the DVI connection to up to a cable length of 30 m</b></p> <ul style="list-style-type: none"> <li>• 1 input / 1 output (DVI-D - f)</li> <li>• Supports HDCP</li> <li>• Up to 1920 x 1200 pixels</li> <li>• Gilded contacts</li> <li>• Incl. power supply 5 VDC</li> <li>• Maximum cable length for installation: 5 m</li> <li>• Plastic casing 46 x 57 x 24 mm</li> <li>• Incl. mounting bracket</li> </ul>	5778 000 017
	<b>DVI splitter basic 1 to 2</b>	<p><b>Splits 1 DVI-D signal to 2 outputs; 1 input / 2 outputs (f)</b></p> <ul style="list-style-type: none"> <li>• Supports 1600 x 1200 @ 60 Hz</li> <li>• Max. cable length between splitter and projector 10 m</li> <li>• Metal casing 200 x 75 x 42 mm</li> <li>• Power supply DC 7.5 V, 1A</li> </ul>	5778 000 003
	<b>DVI splitter pro 1 to 2</b>	<p><b>Splits 1 DVI-D signal to 2 outputs; 1 input / 2 outputs (DVI-I - f)</b></p> <ul style="list-style-type: none"> <li>• 1 input / 2 outputs (DVI-I - f)</li> <li>• Only suitable for digital signals</li> <li>• Maximum data rate 1.65 GBit/s, HDCP conform</li> <li>• Integrated reclocking and equalization</li> <li>• Extended EDID learn and memory function - allows reliable connection to signal source</li> <li>• Metal casing 121 x 75 x 25 mm</li> <li>• Incl. power supply 12 VDC, 180 mA</li> </ul>	5778 000 013





## HDMI signal amplifiers / splitters

Illustration	Model	Specification	Ref. No.
	<b>HDMI extender advanced 1 : 1</b>	<p><b>Extends the HDMI connection to up to a cable length of 30 m</b></p> <p><b>1 input / 1 output (HDMI - f)</b></p> <ul style="list-style-type: none"> <li>• Gilded contacts</li> <li>• HDMI 1.3 certified, HDCP conform</li> <li>• Maximum transmission rate: 340 MHz (10.2 GBit/s)</li> <li>• Maximum cable length for installation: 5 m</li> <li>• Can be operated without power supply, but if unit is used with DVI, higher resolutions or longer cables, we recommend the use of a power supply</li> <li>• Plastic casing</li> <li>• Incl. mounting bracket</li> <li>• Incl. power supply 5 V DC</li> </ul>	5778 000 014
	<b>Monitor splitter advanced HDMI 1 to 4</b>	<ul style="list-style-type: none"> <li>• 1 input / 4 outputs (HDMI - f)</li> <li>• Gilded contacts</li> <li>• HDMI 1.3, HDCP conform</li> <li>• Maximum transmission rate: 340 MHz (10.2 GBit/s)</li> <li>• Metal casing</li> <li>• Incl. power supply</li> </ul>	5778 000 015





## DVI switchers

Illustration	Model	Specification	Ref.N o.
	DVIs hare2 1	<b>Switches two digital DVI sources to 1 display medium</b> <ul style="list-style-type: none"> <li>• 2 inputs / 1 output (DVI-I - f)</li> <li>• 2 select buttons</li> <li>• Status LEDs</li> <li>• Supports 1280 x 1024 pixels and DDC2</li> <li>• Hot plug compatible</li> <li>• Metal casing 153 x 75 x 42 mm</li> <li>• Power supply DC 9 V, 300 mA</li> </ul>	5816 000 006

## HDMI switchers

Illustration	Model	Specification	Ref.N o.
	HDMI share basic 21 automatic	<b>Automatic switching between two HDMI sources</b> <ul style="list-style-type: none"> <li>• 2 inputs / 1 outputs (HDMI - f)</li> <li>• Maximum full HD resolution</li> <li>• No power supply necessary</li> <li>• HDMI 1.3</li> <li>• Dimensions 58 x 63 x 15 mm</li> <li>• Incl. 0.5 m HDMI cable</li> </ul>	5816 000 019
	HDMI share basic 41 remote	<b>Switches via IR remote or RS232 control</b> <ul style="list-style-type: none"> <li>• Inputs: 4 x 19-pin HDMI - f</li> <li>• Outputs: 1 x 19-pin HDMI - f</li> <li>• Supports HDMI 1.3b and HDCP</li> <li>• Resolution up to 1920 x 1200 @ 60 Hz</li> <li>• 12 Bit colours, Dolby true HD and DTS HD master audio</li> <li>• Serial interface for PC control</li> <li>• Incl. power supply, remote control, HDMI cable</li> </ul>	5816 000 010
	HDMI share advanced 31r emote	<b>Switches between the HDMI inputs via IR remote</b> <ul style="list-style-type: none"> <li>• Integrated signal amplifier</li> <li>• 3 inputs / 1 output (HDMI - f)</li> <li>• Maximum transmission rate: 165 MHz (5.2 GBit/s)</li> <li>• HDMI 1.3 certified</li> <li>• HDCP compatible</li> <li>• Metal casing</li> <li>• Incl. remote control and power supply</li> </ul>	5816 000 015
	HDMI share advanced 51r emote	As 5816 000 015 but with 5 inputs	5816 000 016

## Accessories

Illustration	Model	Specification	Ref.N o.
	ECOMANb eamer	<b>Separates the projector from the mains after ca. 5 minutes of operation in standby mode. The integrated IR receiver switches the projector back to standby when it gets an IR signal. If the signal is not meant for the projector, the unit will be switched off again.</b> <ul style="list-style-type: none"> <li>• Time controlled mains separation of projectors (after ca. 5 minutes in standby mode)</li> <li>• High voltage protection</li> <li>• Maximum power 460 W</li> <li>• Power consumption &lt; 1 W</li> <li>• 230 VAC / 50 Hz</li> <li>• Output SCHUKO plug</li> </ul>	7487 000 000
	Kindermann SWITCHBOXP LUS	<b>The SwitchBox Plus in combination with a simple low current switch resp. a potential free contact allows to safely connect and operate several 230 V devices via a thin bell wire.</b> <ul style="list-style-type: none"> <li>• SCHUKO plug</li> <li>• Safety class: IP20, only for dry rooms</li> <li>• Green status LEDs</li> <li>• LOAD CIRCUIT</li> <li>• Voltage: 230V~, 50 Hz</li> <li>• Maximum power: 2000 W (8.7A) / all loads together</li> <li>• CONTROL CIRCUIT</li> <li>• Connection: 2-pin, 5.08 mm</li> <li>• Standard configuration: contacts closed (&lt; 2000 Ohm) --&gt; 230V load switched on --&gt; 230V load switched off</li> </ul>	7487 000 011
	IRI ink	<b>Extends the range of IR remote controls. Extension cable for IR signals sent by remote controls, consisting of:</b> <ul style="list-style-type: none"> <li>• IR receiver</li> <li>• Connector block with power supply 12 V DC</li> <li>• IR emitter with 2 IR diodes</li> <li>• Cable: IR receiver to connector block ca. 2 m*</li> <li>• Cable: connector block to IR emitter ca. 3 m</li> <li>• *Extension possible with 3-pin cable 5698 000 011</li> </ul>	5822 000 005
	Multiple socket with RS232c ontrol	<b>5-fold multiple socket; the individual sockets can be switched on and off via RS232 command.</b> <ul style="list-style-type: none"> <li>• Interface: 9-pin SubD</li> <li>• Max. 1000 W/mains socket</li> <li>• Max. 2500 W overall load</li> </ul>	7487 000 002

## 19" TELESCOPE RACK SYSTEM

For integration in furniture or wall

The racks have telescope rails and can be swivelled up to 90° to the left or right. This allows easy access to the connections of units with a bigger depth in furniture and wall cabinets.

The models vary in depth between 480 and 580 mm and are suitable for smaller custom-made furniture and for wall installation.

- Can hold up to 110 kg
- Engages when extended and when swivelled to 0°, 60° and 90°
- Perfect cable management through cable holders on the rack and bottom part
- 26 rack screws supplied
- 3 mm standard brackets with thread and markings for quick adjustment and installation
- Incl. black anodized cover
- Easy mounting through detachable frame of the rack



Swivelling 19" telescope rack system

12 - 24 RU - 2 rails, can hold up to 55 kg, usable depth 480 mm	8690 000 2xx
12 - 30 RU - 4 rails, can hold up to 110 kg, usable depth 480 mm	8690 000 4xx
12 - 30 RU - 4 rails, can hold up to 90 kg, usable depth 580 mm	8690 000 Xxx

## ACCESSORIES FOR 19" TELESCOPE RACK SYSTEM

### Blind covers

Steel plate, 1.5 mm with scratch-resistant black powder coating



Blind cover, 1 RU	8690 000 101
Blind cover, 2 RU	8690 000 102
Blind cover, 3 RU	8690 000 103
Blind cover, 4 RU	8690 000 104
Blind cover, 5 RU	8690 000 105
Blind cover, 6 RU	8690 000 106

### Ventilation

For smaller pieces of furniture and media centres. The separate thermostat can be positioned where it is suitable.

- Switch-on temperature: 30.5°C
- Switch-off temperature: 29.4°C
- Incl. power supply



Ventilation for furniture	8690 000 030
---------------------------	--------------

### Trays

The "zero" RU tray has fastening elements at the front and at the rear side.

This tray is fixed to the side parts of the brackets and not at the front and therefore offers more usable surface. Two adjustable brackets prevent the units from sliding.

- Easy mounting
- Maximum width of units: 440 mm
- Can hold up to: 115 kg
- Steel plate, 1.5 mm
- Surface: black, powder-coated



- 2 RU tray

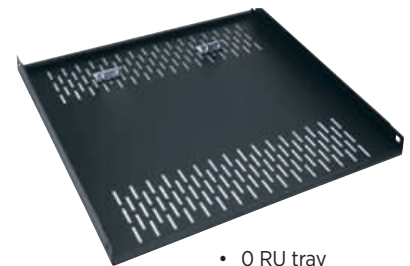

- 0 RU tray

Tray, 0 RU, depth 405 mm	8690 000 020
Tray, 1 RU, depth 280 mm	8690 000 021
Tray, 2 RU, depth 375 mm	8690 000 022
Rack screws, 100 pcs. per package	8690 000 100



## PIXIE plus Mini media control

PIXIE plus is an elegant universal control system for data/video projectors, flat screen displays or smaller AV installations, e. g. consisting of a projector, a ceiling lift or a ceiling mirror, a screen and an audio system. Even an untrained user can easily control any connected device with this AV system.

Especially in conference rooms, schools or other institutions, where various persons have to get along with technical devices day by day, the PIXIE plus makes it much easier to operate projectors and other equipment.

Independent of the projector model there is an identical control unit in each room. Operation errors or the tedious search for the proper remote control with normally too many functions are a thing of the past.

Two to eight buttons with back light and individual labelling allow for easy and intuitive operation. Optional labels are available for ceiling lift, screen etc.

### Exchangeable modules for individual configuration

7 exchangeable modules are supplied; 3 of them can be individually configured



#### Standardized buttons and labels

- For easy and intuitive operation

#### Optional buttons

- For lift, screen etc.

#### Built-in IR sensor

- For easy learning of the IR commands from the original remote control

#### Various mounting options

- Wall (on-wall or in-wall installation)
- Desk (level or with frame)

#### Infrared, RS 232 and relay control

- Offers various control options
- Cable for safe transmission of commands, even over long distances

#### Password protection

- When the password protection is activated, the connected devices cannot be switched on.

#### Macros and timer

- Can be programmed, e. g. for switching on the projector, or for controlling an electrical screen or a ceiling lift
- The programmable timer can switch off the AV equipment automatically if it is not in use.

Technical data	
Ref.No .	5698 000 001
Package includes	PIXIE plus control panel, adapter for Busch-Jaeger Reflex SI fittings, 2-gang mounting frame, white, 1 IR/RS232 module, 7 exchangeable modules, mounting accessories, Euro power supply 100-240 VAC / 6 V DC, 0.8 A
Dimensions	105 x 45 x 30 mm
Required cables for connecting PIXIE plus with an AV device	3-pin cable (+6 V DC, GND, BUS), 0.25-0.75 mm <sup>2</sup> , protected, length up to 50 m, e. g. No. 5698 000 011 (optional accessory)

## Wiring example of a typical application

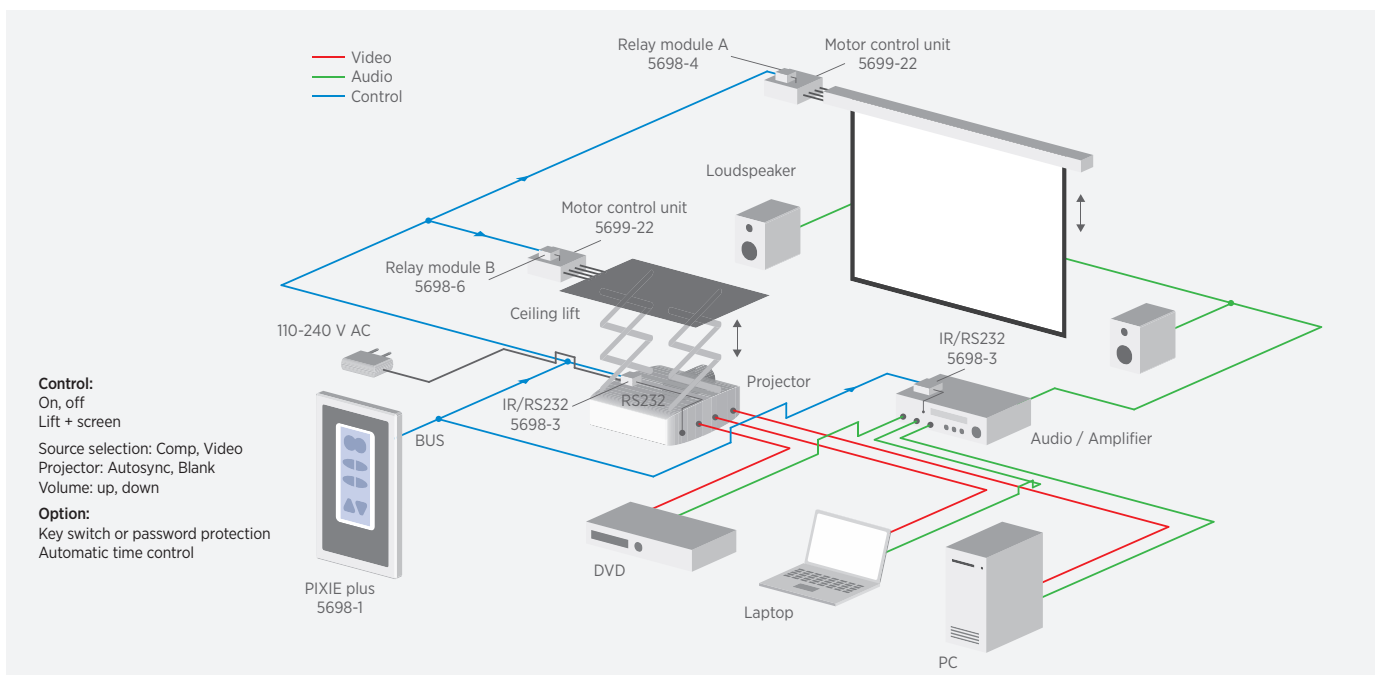



## Optional decor frames

Available in synthetic material, glass, aluminium; for an elegant design and for making the PIXIE plus fit into its surroundings.



### Gira Esprit

Glass, white	5698 000 014
Glass, black	5698 000 015



### Gira Esprit E2, Synthetic material

Aluminium	5698 000 016
Pure white, shiny surface	5698 000 017



### Gira E22

Aluminium	5698 000 018
Stainless steel	5698 000 019



### Aluminium cover for installation level with a desktop

Aluminium cover 130 x 70 x 4 mm	5698 000 020
------------------------------------	--------------

## Accessories for PIXIE plus



### PIXIE plus programming unit

The programming unit which is connected to the PC via USB increases the control features of the PIXIE plus system enormously. Up to 4 commands can be linked via macro for a more complex programming.

The programming of the RS 232, the relay module A, B and the real-time clock module is only possible via the programming unit.

Moreover, automatic time-controlled processes can be programmed.

The whole configuration can be stored on the PC and be later used for other processes or be adapted to them. Thus copying one room programme and transferring it to other rooms can be done in no time.

The newly arranged programme can be stored in the programming unit and be transmitted via IR to the PIXIE plus by simply pressing a button.

PIXIE plus programming unit	5698 000 005
-----------------------------	--------------



### IR/RS 232 module for PIXIE plus

The IR/RS 232 module is equipped with an IR diode and a 2-pin cable with Tx/D OUT and GND for the one-way control via RS 232. It is connected with the 6 V DC, GND, BUS of the PIXIE plus via cable. Up to 5 modules can be connected in a row.

IR/RS 232 module PIXIE plus 1 x IR-, 1 x RS 232 interface for controlling other units	5698 000 003
--	--------------



### Relay module

2 low-voltage relay contacts, max. 48 V/0.4 A, with 2 control LEDs red, green, for contact 1, 2 closed. 1 module A and 1 module B can be used for each PIXIE plus.

Relay module A, 48 V/0.4 A	5698 000 004
Relay module B, 48 V/0.4 A	5698 000 006



### POTI module AUDIO

Stereo motor potentiometer, logarithmic; for remote volume control of a LINE out AUDIO source.

POTI module AUDIO	5698 000 007
-------------------	--------------



### POTI module LINEAR

Stereo motor potentiometer, linear; for remote volume control of an AUDIO source for AUDIO amplifiers with 0-10 V control input.

POTI module LINEAR	5698 000 008
--------------------	--------------



### Real-time clock module

This real-time clock module can be attached to the PIXIE plus to realize different processes (e.g. automatic on/off or password protection at the weekend). For adjusting the time and programming it, the programming unit No. 5698 000 005 is needed.

Clock module For PIXIE plus control panel with 3 V lithium battery	5698 000 002
---	--------------

### Further accessories

Signal cable 3 x 0.25 mm <sup>2</sup> , protected, for connecting the IR/RS 232 modules	5698 000 011
Key switch Exchangeable cover with key switch (for Busch Jaeger)	5698 000 012
Key switch with identical key code Exchangeable cover with key switch	5698 000 013
In-wall casing, 2-gang, modified for PIXIE plus	7441 000 006
On-wall casing, 2-gang, modified for PIXIE plus	7441 000 004



# Kindermann NRC AmpLINC

Media control with network interface and integrated AUDIO technology

The Kindermann NRC AmpLINC integrates the AUDIO technology in a compact media control of good value.

NRC AmpLINC supports up to 6 analogue LINE IN inputs as well as streaming. The user selects all AUDIO sources, controls their volume and an additional microphone. Thus the user can control all audio visual media in one room.

The media control is also available as Pixie Pro NRC, a version without audio technology (No. 567000000).

- Connections:
  - 2 bi-directional RS232 interfaces
  - 2 IR outputs (IR transmitter)
  - 4 low-voltage relay outputs
  - 2 digital inputs
- A software assistant (Java application for PC, Mac) guides the user quickly through the programming.
- The programming and control via a web browser is also possible.
- Up to 16 extension modules for RS232 IR, low voltage relays can be connected to the bus via CAT5 cable.
- Control of e.g. projector, flat screen display, screen, ceiling lift, audio units, house technology (e.g. light, shades) etc.
- Programming of complex processes (macros), which run automatically when pressing a button
- Several NRC systems in different rooms can be controlled centrally via the network.
- Automatic timing: Processes can be exactly planned ahead. Thus the unit can automatically be switched on and start the presentation resp. be switched off in the evenings or at the weekends.
- Ready for 19" rack with optional 19" kit
- V clamp with bracket integrated in the casing e.g. for direct mounting on a projector holder
- Operating units with cable, e.g. PIXIE pro (No. 5699000000), PIXIE plus (No. 5698000001) or any other operating panels with RS 232 interface
- Wireless operation via the free App "RoomTouch for iPad"
- AUDIO streaming (IN/OUT): e.g. for internet radio. Built-in microphone for transmitting events to other rooms.

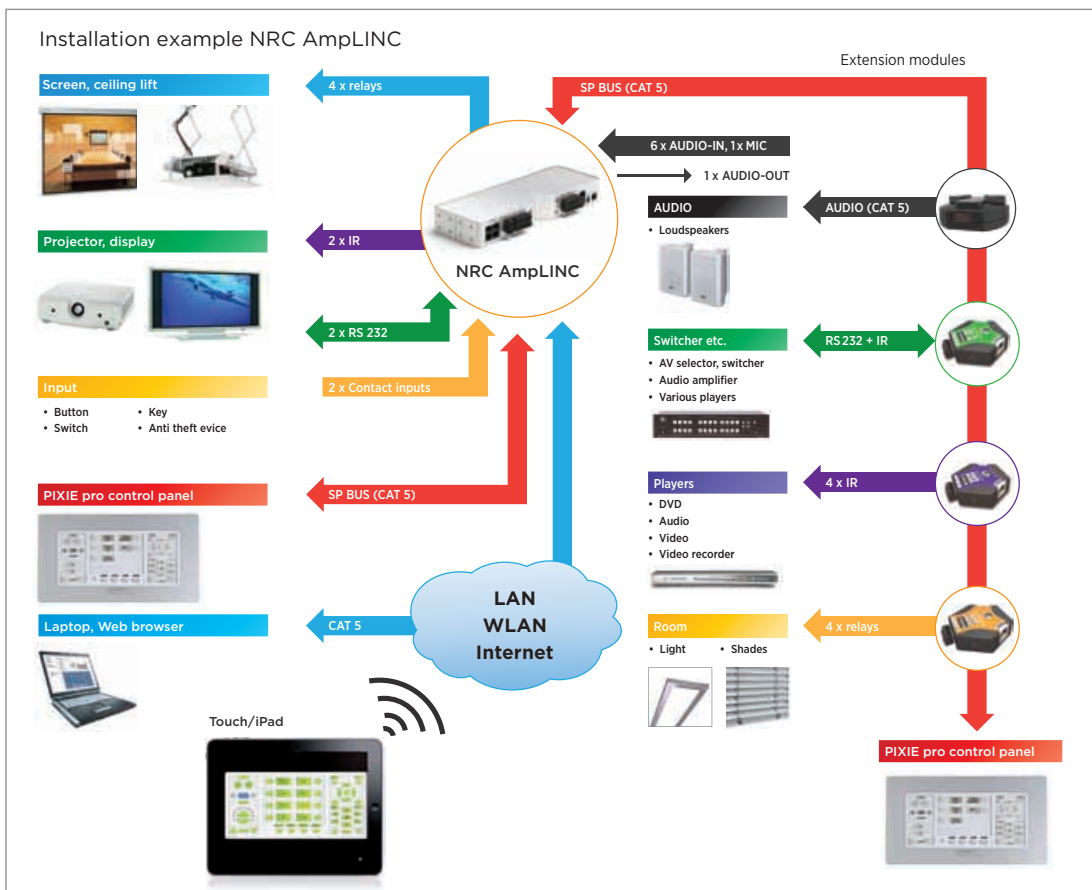

## Kindermann NRC AmpLINC

Media control with network interface and integrated AUDIO switcher



Technical data	
Ref. No.	5670 000 100
Connections (Euro block)	2 IR transmitters 2 bi-directional RS 232 interfaces 4 low-voltage relay outputs 2 digital inputs AUDIO switcher with 6 line stereo inputs 1 microphone input (symmetrical) 1 line stereo output for amplifier 4 RJ 45 bus interfaces
Casing	Aluminium
Power supply	100-240 V AC / 24 V DC, 1.5 A
Dimensions	30.3 x 12 x 4.5 cm
Weight	0.8 kg

## Kindermann NRC

Media control with network interface



Technical data	
Ref. No.	5670 000 000
Connections	1 IR transmitter 1 bi-directional RS 232 interface (sub-D socket, 9-pin) 4 low-voltage relay outputs Euro block 2 digital inputs Euro block 3 CAT5 sockets RJ 45
Casing	Plastic
Power supply	100 - 240 V AC / 12 V DC, 1.25 A
Dimensions	14 x 11 x 3.5 cm
Weight	0.2 kg

## System accessories



<b>AmplINC-AMP 10 module</b> The amplifier modules (10 W) are connected to the NRC AmpLINK via bus and CAT5 cable and to the rear side of the loudspeaker; signals are transmitted via the same cable	5670 000 050
--	--------------



<b>RS 232 / IR control module</b> 1 x RS 232 interface, 1 x IR (transmitter supplied); 60 x 60 x 20 mm, 0.100 kg	5670 000 010
<b>IR-4 control module</b> 4 x IR (transmitter supplied); 60 x 60 x 20 mm, 0.100 kg	5670 000 020
<b>REL-4 control module</b> 4 x relay outputs 24 V DC / 1 A; 60 x 60 x 20 mm, 0.100 kg	5670 000 030



<b>PIXIE pro System Control</b> , operating panel for wall or desk installation, dimensions: 210 x 115 x 35 mm	5699 000 000
--	--------------



<b>Aluminium cover</b> , exchangeable cover for PIXIE pro, for integration e.g. level with the furniture, elegant design, 220 x 120 x 3 mm	5699 000 019
--	--------------



<b>Motor control with relay input</b> , control of a screen or a ceiling lift in 2 stop positions and random stops in between, via two low-voltage relay contacts	5699 000 022
---	--------------



## PROTOUCH

### Multi functional room control

The Kindermann ProTouch media control is compatible with all standard bus systems, e. g. EIB/KNX, RS 232/422 and DMX. Due to the use of IP network interfaces individual scaling is possible, so that even with large installations all types of control can be carried out reliably. Classic media technology, e.g. projectors, displays, screens, lifts etc. can be integrated via RS 232 interfaces, infrared or wireless contacts.

A script language, a user surface that can be individually designed, as well as touch screen displays guarantee a user interface which can be intuitively operated and at any time be adapted to the user's requirements.

Should you need any help with the operation or wish additional programming, a remote access of our support to your system is possible.

### Example of a configuration

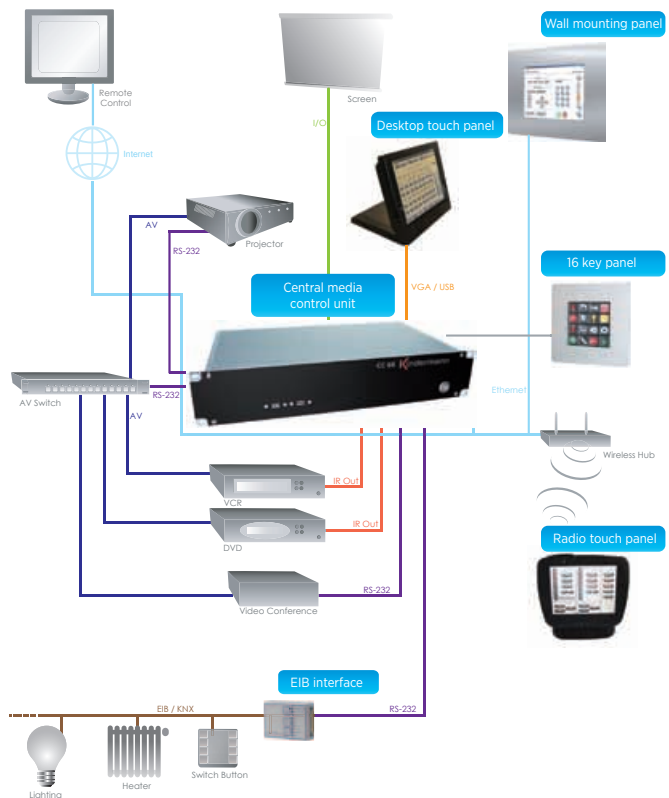

## Kindermann CC88 media control

### Central control unit for media control

The ProTouch CC88 features a sufficient number of interfaces for conventional media technology as well as multimedia functions, e. g. for playing power point, audio and video data.

A VGA port as well as a 10/100 Mbit Ethernet port are integrated. An individual number of CC88 can communicate with one another and carry out control functions in different rooms.

As the CC88 has no mechanical parts and can be password protected (optional), the system is especially safe and good for long life.

The programming language with focus on events and objects meets the demands of a flexible media control due to its simple structuring.

Freely programmable media control with various inputs and outputs. Ideal for complex controls of conference rooms, can be scaled and supplemented.

With the help of the integrated editor processes can be intuitively determined via mouse click.

Beginners become familiar with the system quickly and experienced programmers can define the most complex structures including data banking on their own. The programming, however, can also be done by the manufacturer if you wish.



- 19" - 2 RU
- 1 GHz CPU - 1 GB RAM
- 2 GB flash memory
- Embedded operation system
- 6 x bi-directional RS 232
- 4 x un-directional RS 232
- 8 x digital input
- 8 x relay switcher 48 V/ 60 W
- 8 x analogue input 0-10 V
- 8 x analogue output 0-10 V
- 8 x IR transmitter
- 1 x IR receiver

- 10/100 MB Ethernet
- 4 x USB 2.0
- On/off via calendar functions or external push button
- Integrated watch dog function
- Connection for touch panels up to SXGA
- Output 3.5 mm jack
- Weight: ca. 4.1 kg
- 3 x IR transmitter (5400 000 300) supplied



## Touch panels

Touch panels make an intuitive operation possible, they are a preferred user interface. The single units communicate with the central control unit via standard network protocol TCP/IP - either via cable or WLAN, depending on the model.

Alternatively a standard touch screen monitor can be directly connected to the CC88 via VGA and RS 232 or USB.

With the design software which the CC88 is supplied with surfaces can be individually designed for any application and adapted e.g. to your corporate design.



### Desk touch panel PC 12.1" for CC88

#### 12.1" touch display with integrated PC, cable connection

- 600 MHz CPU, 512 MB RAM, 40 GB HD
- Resolution 1024 x 768 pixels
- Embedded operation system
- 10/100 MBit network connection for the communication with the central control unit
- Dimensions: 240 x 240 x 200 mm
- Weight: 7.2 kg

Desk touch panel PC 12.1" for CC88

5400 000 412



### Desk touch panel 10.4" for CC88

#### 10.4" touch display

- Resolution SVGA, 800 x 600 pixels
- Connection to media control CC88 via VGA or DVI and RS 232 or USB
- Dimensions: 257 x 230 x 213 mm
- Weight: ca. 6 kg

Desk touch panel 10.4" for CC88

5400 000 410



### WLAN touch panel PC 8.4" for CC88

#### Mobile battery operated 8.4" touch panel PC incl. docking station

- Resolution: 800 x 600 pixels
- 500 Mhz CPU, 512 MB RAM, 1 GB CF card
- Embedded operation system
- Network: WiFi 802.11a/b/g
- LAN 10/100 MBit
- Desk battery charger
- Operating time: up to 4 hours before recharging
- Dimensions: 240 x 200 x 18 mm
- Weight: ca. 0.9 kg incl. battery

WLAN Touch panel PC 8.4" for CC88

5400 000 428



### 16 button wall panel

- For wall mounting
- Connection to media control CC88 via RS 232 cable (1:1)
- All buttons can be individually labelled
- 5 mm decor frame, aluminium (120 x 120 mm)

16 button wall panel

5400 000 440



### Docking station for 8.4" touch panel PC

- For wall mounting
- Vesa conform
- 2 x USB
- 1 x network 10/100 MBit

Docking station für 8.4" touch panel PC

5400 000 438

## Interface extensions

If the existing interfaces are not sufficient or a connection to the bus system of a building is required, we offer various additional inter-

face modules and give you advice as to the components that suit your demands.

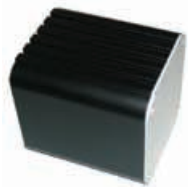

### USB / DMX-512 interface

- Operation status via LED display
- For light control via DMX protocol
- Connection and power supply via USB
- Dimensions: 72 x 66 x 80 mm

USB / DMX-512i interface

5400 000 401



### EIB interface

- RS 232 / EIB / KNX interface for bi-directional communication with the house technology
- Any number of group addresses can be activated
- Supports EIS data types EIS1, EIS2, EIS5 and EIS6
- Incl. software for the configuration of the group addresses
- Dimensions: 68 x 95 x 28 mm

EIB interface

5400 000 402



### LAN / RS 232 interface

**For controlling units with RS 232 interface over large distances**

- 1 x RS 232 interface
- Allows the control of a unit with RS 232 interface via an IP network
- Power supply: 12V / 200 mA
- Dimensions: 50 x 80 x 22 mm

LAN / RS 232 interface

5400 000 403

### IR emitter diode for media control CC88

**IR emitter diode with status display**

- 2 m cable with open ends
- Self adhesive
- For CC88

IR emitter diode for media control CC88

5400 000 300



# MOBILE AUDIO SYSTEMS

How to choose the proper audio equipment

- Size of the audience
- Surroundings
- Speech and / or music
- Mains available



## Kindermann MobileBox 75W / 2 receivers

### Mobile battery-operated audio system

- Power: 75 Watt
- Incl. CD player, cassette recorder, radio microphone
- Maximum sound impact: 110 dB
- Inputs: 2 x line, 2 x microphone
- Weight: ca. 13 kg

### Technical data

<b>Model</b>	Kindermann MobileBox 75W / 2 receivers
<b>Ref. No.</b>	8700 000 002
<b>Features</b>	cassette recorder, CD player, UHF radio microphone
<b>Power</b>	75 Watt (battery / mains operation)
<b>Max. sound impact</b>	110 dB
<b>Speaker</b>	1 x 8" full range, 4 Ohm
<b>Transmission range</b>	50 Hz - 18 kHz, +/- 3 dB
<b>Inputs</b>	2 x line (stereo cinch / 6.3 mm jack), 2 x microphone (XLR / 6.3 mm jack)
<b>Outputs</b>	1 x line, 1 x loudspeaker (2 x 6.3 mm jack)
<b>Charging time</b>	ca. 6 hours
<b>Power supply</b>	230 V / 50 Hz
<b>Dimensions</b>	44 x 33 x 24 cm
<b>Weight</b>	ca. 13 kg
<b>Radio microphone</b>	
<b>Radio microphone</b>	UHF, true diversity
<b>Frequency</b>	863.125 - 864.875 MHz, 16 pre-programmed frequencies
<b>Modulation/oscillation</b>	FM / PLL synthesizer
<b>Stability</b>	± 0.005 %
<b>Frequency response</b>	60 Hz - 15 KHz (± 3 dB)
<b>Distortion factor</b>	<1% (@ 1 KHz)



## ACCESSORIES

### Microphone holder

16 switchable frequencies, 863-865 MHz



### Additional portable microphone



### Pocket sender



Receiver module 8700 000 003

Additional portable microphone 8700 000 004

Pocket sender incl. lavalier microphone	8700 000 006
Pocket sender incl. neck microphone	8700 000 005

## Beacon 7500 MU1/MU2

### Mobile battery-operated audio system

- Power: 125/150 Watt
- Maximum sound impact: 112 dB
- Inputs: 2 x Mic XLR/6.3 mm with phantom voltage, 1 x 3.5 mm / 1 x 6.3 mm jack, 1 x stereo cinch
- Weight: ca. 23 kg



### Technical data

Model	Beacon 7500 MU1	Beacon 7500 MU2
Ref.No .	8703 000 006	8703 000 007
Features	MP3 players for SD, USB memory	
Radioreceiver	1 UHF	2 UHF
Power	125 W (battery operation), 150 W (mains operation)	
Max. sound impact	112 dB	
Speaker	3 x 8" subwoofer, 8x 4" tweeter	
Transmission range	60 Hz - 15 kHz +/- 3 dB	
Inputs	2 x Mic XLR/6.3 mm with phantom voltage, 1 x 3.5 mm / 1 x 6.3 mm jack, 1 x stereo cinch	
Output	1 x stereo cinch	
Charging time	ca. 7 hours	
Power supply	100-240 V AC, 50/60 Hz, 300 W max.	
Dimensions	66.7 x 28 x 45.7 cm	
Weight	ca. 23 kg	
Frequency	863.125 - 864.875 MHz (16 pre-programme, frequencies)	
Modulation/oscillation	FM/PLL synthesizer	
Stability	+/- 0,005 %	
Distortion factor	< 1%(@1 KHz)	

## Liberty 7500 MU1/MU2 with MP3 player

### Mobile battery-operated audio system

- Power: 125/100 Watt
- Maximum sound impact: 110 dB
- Inputs: 2 x Mic XLR/6.3 mm with phantom voltage, 1 x 3.5 mm / 1 x 6.3 mm jack, 1 x stereo cinch
- Weight: ca. 17 kg



### Technical data

Model	Liberty 7500 MU1	Liberty 7500 MU2
Ref.No .	8703 000 026	8703 000 027
Features	MP3 player for SD, USB memory	
Radioreceiver	1 UHF	2 UHF
Power	125 W (battery operation), 100 W (mains operation)	
Max. sound impact	110 dB	
Speaker	1 x 10" subwoofer	
Transmission range	60 Hz - 15 kHz +/- 3dB	
Inputs	2 x Mic XLR / 6.3 mm with phantom voltage, 1 x 3.5 mm / 1 x 6.3 mm jack, 1 x stereo cinch	
Outputs	1 x stereo cinch	
Charging time	ca. 7 hours	
Power supply	100-240 VAC, 50/60 Hz, 300W max.	
Dimensions	56 x 35.6 x 29.2 cm	
Weight	ca. 17 kg	
Frequency	863.125 - 864.875 MHz, 16 pre-programmed frequencies	
Modulation/oscillation	FM/PLL synthesizer	
Stability	+/- 0,005 %	
Distortion factor	< 1%(@1 KHz)	
Model	Liberty 7501 - additional passive loudspeaker	
Ref.No .	8703 000 028	
Inputs	1 x Speakon, 4-pol 8 Ω	



## Explorer Pro 7500

### Mobile battery-operated audio system

- Output (battery operation): 30 Watt
- Output (mains operation): 75 Watt
- Maximum sound impact: 110 dB
- Inputs 2 x microphone with 12 V, 1 x line
- Weight: 10.4 kg



### Technical data

Model	Explorer Pro 7500 mains operation	Explorer Pro 7500 U1 1 radio receiver	Explorer Pro 7500 U2 2 radio receivers	Explorer Pro 7501 additional passive loudspeaker
Ref. No.	8703 000 030	8703 000 031	8703 000 032	8703 000 039
Power battery operation (Watt)		30		
Power mains operation (Watt)		75		
Max. sound impact		110 dB		
Speaker		1 x 6.5" subwoofer, 1 x tweeter		
Transmission range		80 Hz - 16 kHz (+/- 3dB)		
Inputs		2 x microphone with 12 V phantom voltage, 1 x line (6.3 mm jack/stereo cinch)		
Outputs		1 x line (6.3 mm jack), 1 x 4-pin speakon		
Charging time		ca. 1 hour		
Power supply		90 - 264 V AC, 50/60 Hz		
Dimensions		42 x 27 x 25 cm		
Weight		ca. 10.4 kg		
Receiver		UHF, true diversity		
Modulation/oscillation		FM/PLL synthesizer		
Stability		+/- 0.005 %		
Distortion factor		< 1%(@1 KHz)		

## ACCESSORIES FOR MOBILE SOUND SYSTEMS

### Pocket sender for mobile boxes Beacon, Liberty and Explorer Pro

- Capacity: 10 mWatt
- Operation time: up to 20 hours
- Power: 65 mA +/- 10 mA
- Handheld sender: 267 mm long, ø 55 mm
- Pocket sender: 98 x 66 x 26 mm
- Power supply: 2 x 1.5 V battery (AA)



Pocket sender for mobile boxes (8703-xxx) 8703 000 110

### Portable microphone for mobile boxes Beacon, Liberty and Explorer Pro



Portable microphone for mobile boxes (8703-xxx) 8703 000 100

### Speaker tripod for Liberty and Explorer Pro



Speaker tripod for Liberty and Explorer Pro 8703 000 126

### Lavalier microphone

For pocket sender 8703 000 110

Lavalier microphone 8703 000 113

### Headset microphone

For pocket sender 8703 000 110

Headset microphone 8703 000 114

### Soft case

With castors and telescope grip

Soft case for Liberty 8703 000 123  
Soft case for Explorer Pro 8703 000 124

# ACTIVE LOUDSPEAKERS

## Kindermann ActiveBox set 50+

Loudspeaker set consisting of active and passive box

- Power: 30 W RMS / 50 W music
- Inputs: 1 x stereo cinch, 1 x 3.5 mm jack, 1 x symmetric (Euro block)
- Weight: 5.75 kg



**Please note!**

Also available with IR remote control (8705 000 022 / 8705 000 023 )

**Technical data**

Model	Kindermann ActiveBox set 50+ white	Kindermann ActiveBox set 50+ black
Ref. No.	8705 000 020	8705 000 021
Package includes	Incl. connection cable and wall mount	
Power RMS / music	30 W / 50 W	
Speaker	1 x 5.25" subwoofer, 1" tweeter	
Frequency	45 Hz - 20 kHz	
Emission	120° x 100°	
Inputs	1 x cinch stereo, 1 x 3.5 mm jack, 1 x symmetric (Euro block)	
Outputs	loudspeaker (Euro block)	
Sound controls	Volume, treble, bass	
Power supply	230 V / 50 Hz	
Dimensions	23.8 x 18 x 17 cm	
Weight	ca. 5.75 kg	

## Kindermann ActiveBox set 75+

Loudspeaker set consisting of active and passive box

- Power: 50 W RMS / 80 W music
- Inputs: stereo, cinch
- Weight: 8.9 kg



**Technical data**

Model	ActiveBox set 75+ white	ActiveBox set 75+ black
Ref. No.	8705 000 025	8705 000 026
Package includes	Wall mount, mains cable, loudspeaker cable	
Power RMS / music	50 W / 80 W	
Speaker	1 x 6.5" subwoofer, 0.8" tweeter	
Frequency	45 Hz - 20 kHz	
Emission	90° x 90°	
Inputs	stereo, cinch	
Outputs	3-pin XLR (m)	
Sound controls	Volume, treble, bass	
Power supply	230 V / 50 Hz	
Dimensions	30 x 21.5 x 19 cm	
Weight	ca. 8.9 kg	

## Kindermann ActiveBox Dome set 20

Active stereo set for direct fixing on a projector ceiling mount or for use on a conference table

- Power: 2 x 10 W
- Broad band loudspeaker: 2 x 2.75"
- Frequency: 155 Hz - 20 kHz
- Input: adjustable LINE out, 3.5 mm jack, e.g. from laptop
- Power supply: 100 - 240 V AC, 50/60 Hz, 12 V DC, 2A
- Audio cable: 3.5m jack/jack, 1.5 m
- Dimensions: Ø 25 cm, height 9 cm
- Weight: 1.2 kg
- Adapter for round columns, Ø 35, 40, 45, 50 mm
- Adapter for square columns 40 mm



## Kindermann ActiveBox set 40+

Active loudspeaker set consisting of an active loudspeaker with 2 x 20 Watt stereo amplifier and volume control, and a passive loudspeaker

- Power: 2 x 20 W
- Input: line level, 3.5 mm stereo jack or clamp and screw
- Output: 1 socket for passive loudspeaker
- Type: 2-way bass reflex loudspeaker
- Package includes: 2 mounting brackets, 3 m 230 V mains cable
- Subwoofer: 5.25"
- Tweeter: 0.75"
- Frequency: 45 Hz - 20 kHz
- Maximum sound impact: 85 dB (1 W/1 m)
- Power supply: 115 - 230 V
- Weight: 3.57 kg (active), 2.53 kg (passive)
- Colour: white or black



Kindermann ActiveBox Dome set 20 8705 000 029

Kindermann ActiveBox set 40+ white	8705 000 027
Kindermann ActiveBox set 40+ black	8705 000 028

## MIXER / AMPLIFIER



### Kindermann automatic mixer AM 62

For 6 input and 4 output signals, can be controlled via RS 232

- Inputs: Mic/line 1-4 connections XLR 3-pin female, Aux 5-6 connections 2 x cinch
- Outputs: line, left and right connections 2 x XLR male, recording, left and right connections 2 x cinch
- Control: serial RS 232 via 9-pin SubD, analogue E/A's via contacts and VCA
- Dimensions: 483 x 44 x 200 mm / 1 RU
- Colour: black RAL 9005
- Weight: 3.5 kg



### Teac AR 650 HiFi amplifier

High-quality stereo amplifier with microphone input

- Power: 2 x 90W RMS @ 8 Ω 2 x 120 W RMS power @ 4 Ω
- 7-fold input selector: tape1, tape2, AUX1, AUX2, CD, tuner, phono
- Motorized master volume control
- Sound and balance control
- Adjustable microphone input for karaoke programmes
- Output "A" with sturdy loudspeaker clamp connections
- Headset connection 6.3 mm
- Dimensions: 435 x 142 x 355 mm
- Weight: 9.7 kg

Automatic mixer AM 62

8715 000 190

Teac AR 650 HiFi amplifier

8715 000 022

### MMC 84

3 units in one: MultiMedia switch, digital audio processing and audio amplifier with 75 Watt

- 19", 2 RU
- Inclusive 2 x 2 VGA matrix
- Can be controlled via RS 232
- Symmetric and unsymmetric audio inputs and outputs
- Phantom voltage 12 V, selectable loudspeaker output 75 W / RMS EQs for all inputs and outputs
- Ideal as complete compact solution for small and midsize conference rooms
- Inputs and outputs on the front and back
- Switchable electricity output for further units (e.g. media control, radio receiver)



MMC 84

5400 000 010

# MICROPHONES

Wireless MicSet 1    Wireless MicSet 2    Wireless MicSet 3



## Technical data

Model	Wireless MicSet 1-3
Frequency response	50 Hz - 15 kHz (+/-3 dB)
Output	1 x sym. XLR (ca. 77 mV), 1 x unsym. 6.3 mm jack (ca. 770 mV)
Dynamic	96 dB
Frequency	16 channels between 863.125 and 864.875 MHz
Transmission range	ca. 50 m depending on local conditions
Capacity	10 mW
Operating time	ca. 10 hours
Power supply	230 V AC / 12 V DC, sender 2 x 1.5 V (AA) or battery
Dimensions	9.5", 1 RU
Package includes	XLR cable 1 m, 19" adapter (only in combination with second receiver)

<b>Kindermann Wireless MicSet 1</b> Consisting of diversity receiver and portable sender	8720 000 002
<b>Kindermann Wireless MicSet 2</b> Consisting of diversity receiver, pocket sender and lavalier microphone	8720 000 003
<b>Kindermann Wireless MicSet 3</b> Consisting of diversity receiver, pocket sender and headset microphone	8720 000 004

## UHF radio microphone sets



## Technical data

Model	UHF radio microphone set
Frequency response	50 Hz - 18 kHz
Output	1 x sym. XLR plug, 1 x sym. 6.3 mm jack, microphone/line switchable
Modulation	FM/PLL synthesizer
Frequency	16 channels, 798 - 822 MHz
Transmission range	ca. 100 m depending on local conditions
Capacity	10 mW
Operating time	15 hours
Power supply	230 V AC / 17 V DC, sender 1 x 9 V (block) or battery
Dimensions	210 x 206 x 44 mm
Weight	Portable microphone 0.240 kg / pocket sender 0.085 kg

<b>UHF radio microphone set ACT707 SEH</b> With portable microphone	8720 000 011
<b>UHF radio microphone set ACT707 SE TL</b> Incl. pocket sender and lavalier microphone	8720 000 012
<b>UHF radio microphone set ACT707 SE THS</b> Incl. pocket sender and headset microphone	8720 000 013

## Kindermann swan neck microphones

Three models of various lengths for permanent installation are ideal for arranging the optimum distance between the speaker and the microphone head. In addition, the flexible swan neck allows the speaker to re-adjust the microphone while lecturing.

- Cardioid directional characteristic
- Connection: XLR male
- Phantom voltage: 9 - 52 V
- Supplied with wind protection



<b>Swan neck microphone, black, length: 300 mm</b>	5100 000 704
<b>Swan neck microphone white, length: 300 mm</b>	5100 000 705
<b>Swan neck microphone black, length: 550 mm</b>	5100 000 703
<b>Swan neck microphone white, length: 550 mm</b>	5100 000 706
<b>Swan neck microphone black, length: 760 mm</b>	5100 000 707
<b>Swan neck microphone white, length: 760 mm</b>	5100 000 708

## Portable microphone Opus 39S

**Dynamic portable microphone with super cardioid directional characteristic**

- Frequency response: 50 Hz - 16 kHz (close by)  
100 Hz - 14 kHz (at 1 m distance)
- Impedance: 600 Ω
- Connection: 3 pol. XLR
- Weight: 310 g



## Microphone stand

- Colour: black
- Height adjustment from 90 - 160 cm
- Swivelling arm: 81 cm
- Weight: 2.3 kg
- Incl. microphone holder



## Desktop stand & microphone holder

- Colour: grey
- Compact round base ø ca. 6 cm
- Height: ca. 6 cm
- Incl. microphone holder



Portable microphone Opus 39S	8720 000 015	Microphone stand	8720 000 010	Desktop stand & microphone holder	8720 000 014
------------------------------	--------------	------------------	--------------	-----------------------------------	--------------





## GUIDELINE FOR LARGE-SCREEN PROJECTION

### How to choose the proper type of screen

Which screen is to be preferred first of all depends on the application. For frequent shows in the same location a screen installed on the wall or ceiling should be considered, either for electrical or manual operation, with or without frame. For shows in different locations a tripod screen resp. a portable screen is the better solution.

#### Electrical - for installation



#### Manual - for installation



#### Framed screen



#### Mobile



### How to choose the proper picture format

1:1

#### Standard format for overhead or slide projection

Width = height

4:3

#### Video format for presentations and TV

Height = width : 1.33

16:10

#### Wide image format

Height = width : 1.6

### How to choose the proper height of the screen (4:3)

- **Height of the screen**  
= 1/6 of its distance to the last row of seats
- **Distance between the screen and the first row of seats**  
= height of screen x 1.5
- **Minimum distance between the screen bottom and the floor**  
= 60 - 90 cm for home cinema use  
> 1.25 m if the audience is sitting  
> 1.60 m if the audience is standing
- Consider the ceiling height

Example

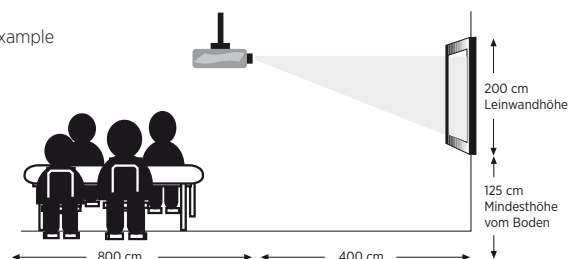

### How to choose the proper light output of the projector

The light intensity reflected by the projection screen is measured in lux. For an optimal picture quality the ratio between the lux value of the projected image and that of the room light should be at least 5:1, or even better > 10:1.

As a thumb rule the normal room light in conference rooms is about 100 lux.

The light intensity reflected by the screen should then be more than 1000 lux.

$$\text{Lux} = \frac{\text{lumens (ANSI) projector}}{\text{projection surface in m}^2} \times \text{reflection value (Gain)}$$

Lux = 100 (slightly lit room)

Lux = 400 (normally lit room)

# PROJECTION SCREENS

## How to choose the proper screen fabric

### Reflection factor / Gain:

The reflection factor (Gain) indicates the intensity of the reflection. The basis for determining the reflection factor is magnesium carbonate ( $MgCO_3$ ), which does not absorb light but reflects it evenly – this corresponds to the reflection factor Gain 1.

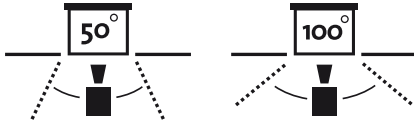

### Viewing angle

The viewing angle of the projection screen indicates the maximum angle at which the projected image is still clearly visible.

The brightness of the image decreases when the viewing angle increases.

The maximum angle is the point where the viewers are exposed to less than 50 % of the light intensity of the image.



### Diffuse

A diffuse screen fabric spreads the light evenly and has a large viewing angle so that a reflection factor is achieved which is close to the standard value of 1.0. The projector can be mounted on a ceiling or placed on a table.

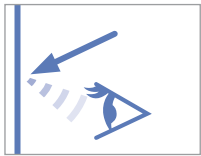

### Reflective

A reflective screen fabric directs the projected light from the projector mounted on the ceiling towards the viewer.

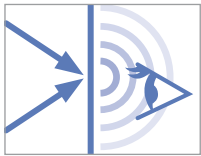

### Diffuse transmissive (rear projection)

A diffuse transmissive screen fabric is needed for rear projection. The image is projected on the rear side and through diffusion transmitted to the front surface of the screen. The projector can either be mounted on the ceiling or placed on a table.



### Matt white:

Matt white is one of the most versatile screen fabrics with a large viewing angle. Therefore this screen fabric is the ideal solution for surroundings in which the room light can be controlled and in which an especially large viewing angle is required.

### Matt white/SE - flame retardant screen fabrics:

Flame resistant according to fire safety regulations B1, DIN 4102.

- Thickness: ca. 0.7 mm
- Weight: ca. 820 g/m<sup>2</sup>
- Surface: PVC coated polyester on both sides
- Up to 300 cm screen width = No. of certificate P-BRA09-3165407
- More than 300 cm screen width = No. of certificate P-MPA-E01-526



### Datalux:

The reflective coating of this screen fabric provides more brightness, which reduces the viewing angle. Therefore this fabric is suitable if the room light cannot be controlled and a projector with a smaller light output is used.



### Da-Tex:

Da-Tex® is a special fabric for rear projection, i. e. the projector is behind the screen and the image is transmitted through diffusion to the front surface of the screen.

### General information

- The screens Elpro large electrol, Elpro (RF) electrol, (Tensioned) Descender (RF) Electrol, Compact (RF) electrol were tested and certified as to their quality, electrical fittings, safety and longterm use.



- All screens are designed and produced according to DIN 19045, part 1-5.
- The screen casings are made of steel or aluminium.
- Black rims are a standard feature of all screens.

### Format 1:1

Up to 240 cm width left / right 2.5 cm;  
more than 240 cm width left / right 5 cm

### Format 4:3 and 16:10

Full frame 5 cm

Panorama, Jumbo, Cineroll Electric und Cineflex Electric IR:

### Features of electrical screens

- Motor with thermal fuse and stop system against idling
- Motor on the left side (standard) - on the right side on demand
- Cineroll Electric, Panorama Jumbo Motor on the right side (standard) - on the left side on demand
- Supplied with connection cable
- Easy stop adjustment of the motor through openings at the bottom of the casing
- All electrical screens correspond to the international guidelines as to product safety, electrical safety resp. electro-magnetic compatibility: IEC 60335-1, 60335-2, DIN 19045-5, IEC 61000



## EASY INSTALL

### Easy mounting of screens

The flexible mounting system "Easy Install" makes the installation of projection screens even easier. This saves time and installation costs.



#### Plug & play accessories

The plug & play accessories enable every user to install an electrical screen: Just put the plug into the socket of the screen and the cover on the wiring, and the screen is ready to use.

#### Easy and comfortable

First two brackets are fixed on the wall or ceiling. Then the screen is inserted in the brackets and secured with screws. Even large screens can be easily mounted like this.

#### Flexible installation

The position of the mounting elements does no longer depend on the width of the screen. The mounting brackets can be fixed on the wall or ceiling in a distance of up to 50 cm from both edges of the screen.

## Accessories for Easy Install screens

Illustration	Model	Specification	Cable length	Ref. No.
	Radio remote control	Plug & play with receiver, 4-channel remote, mains cable with Schuko plug, range up to 30 m	5 m	5944 000 011
	On-wall push button	For radio remote control (5944 000 011) 868.3 Mhz		5944 000 017
	IR remote control	Plug & play with receiver, remote, mains cable with Schuko plug, range up to 7 m	5 m	5944 000 012
	Relay box	Plug & play, for controlling screens via a media control	5 m	5944 000 014



# DESCENDER ELECTROL

- Sturdy steel casing with integrated L profile for holding the false ceiling
- Fast moving low-noise motor
- Easy service system: Easy access of motor and screen through a flap for servicing after the installation – for replacing the motor or the fabric the casing need not be dismantled
- The trapeziform profile of the bottom bar of the screen is level with the casing when the screen is rolled up.
- Colour RAL 9016 (white)
- Custom-made versions available on demand, including an “RF” version with built-in radio remote control

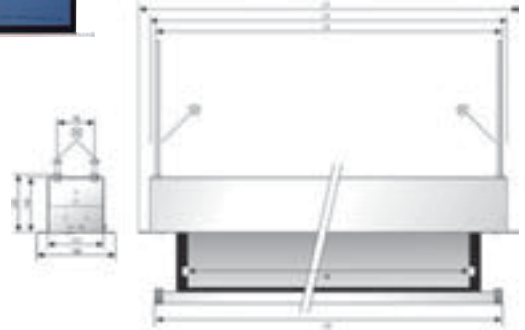

Overall dimensions	Screen size	Dimensions in mm (see illustration)			Weight	Screen fabrics	Ref. No.
		L1	L2	L4			
<b>Format 1:1</b>							
180 x 180 cm	173 x 173 cm	2039	1959	1989	19 kg	Matt white	7459 000 000
200 x 200 cm	195 x 195 cm	2259	2197	2209	21 kg	Matt white	7459 000 001
240 x 240 cm	230 x 230 cm	2659	2597	2609	29 kg	Matt white	7459 000 003
300 x 300 cm	290 x 290 cm	3259	3179	3209	37 kg	Matt white	7459 000 005
<b>Format 4:3</b>							
138 x 180 cm	126 x 168 cm	2039	1959	1989	19 kg	Matt white	7459 000 006
153 x 200 cm	143 x 190 cm	2259	2197	2209	21 kg	Matt white	7459 000 007
183 x 240 cm	173 x 230 cm	2659	2597	2609	26 kg	Matt white	7459 000 009
228 x 300 cm	218 x 290 cm	3259	3179	3209	33 kg	Matt white	7459 000 011
<b>Format 16:10</b>							
129 x 200 cm	119 x 190 cm	2259	2197	2209	20 kg	Matt white	7459 000 012
154 x 240 cm	144 x 230 cm	2659	2597	2609	25 kg	Matt white	7459 000 014
191 x 300 cm	181 x 290 cm	3259	3179	3209	30 kg	Matt white	7459 000 016

# TENSIONED DESCENDER ELECTROL

- As Descender electrol - but with tautening mechanism on either side, for perfectly plain projection surface
- Special projection surface for tautening mechanism

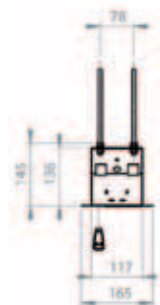

Overall dimensions	Screen size	Dimensions in mm (see illustration)			Weight	Screen fabrics	Ref. No.
		L1	L2	L3			
<b>Format 4:3</b>							
153 x 200 cm	143 x 190 cm	2431	2351	2113	27 kg	Matt white	7459 000 051
183 x 240 cm	173 x 230 cm	2819	2739	2481	32 kg	Matt white	7459 000 053
228 x 300 cm	218 x 290 cm	3471	3391	3114	39 kg	Matt white	7459 000 055
<b>Format 16:10</b>							
129 x 200 cm	119x 190 cm	2431	2351	2113	26 kg	Matt white	7459 000 056
154 x 240 cm	144 x 230 cm	2819	2739	2481	30 kg	Matt white	7459 000 058
191 x 300 cm	181 x 290 cm	3471	3391	3114	37 kg	Matt white	7459 000 060



# CINEROLL ELECTRIC

## For professional installation

- Square steel casing with a cross section of 9 x 9 cm, resp. 10.5 x 10.5 cm for screens wider than 250 cm
- No visible screws on the casing of the screen
- Vario Mounting System (VMS) for easy and comfortable wall or ceiling mounting (similar to "Easy Install" system)
- The bottom bar with a trapeziform profile closes the casing when the screen is rolled up
- Colour of casing: RAL 9003 (white)

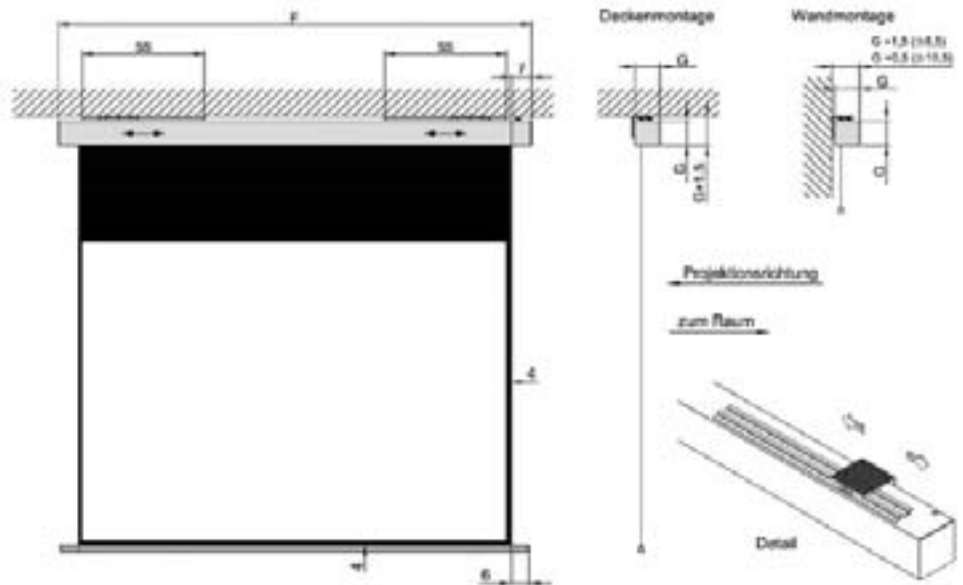
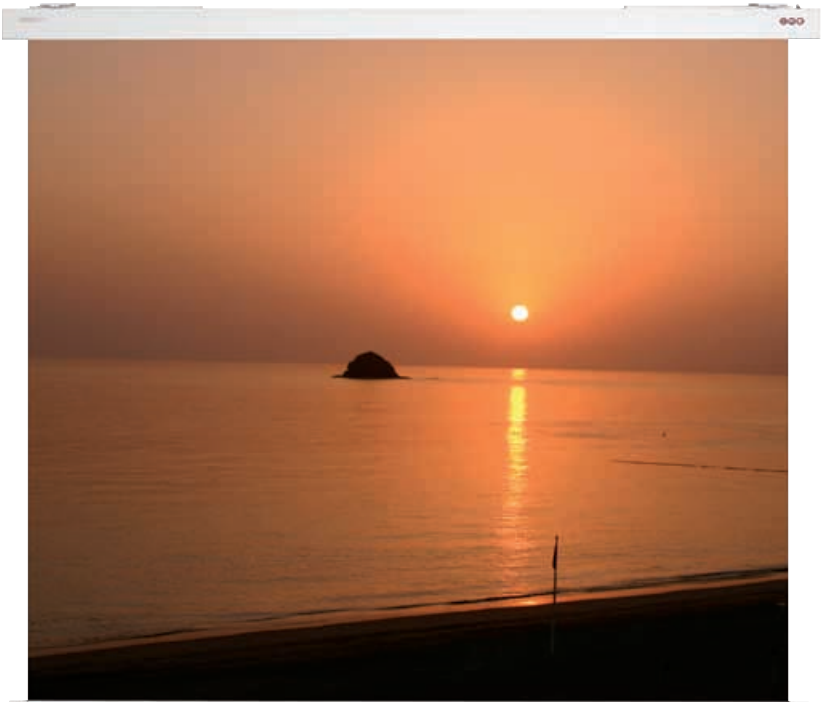

Overall dimensions	Screen size*	Dimensions in cm (see illustration)		Weight	Screen fabrics	Ref. No.	Screen fabrics	Ref. No.
		F	G					
<b>Format 1:1</b>								
180 x 180 cm	180 x 180 cm	194	9	16 kg	Matt white	7413 000 000	Matt white/SE	7413 000 200
200 x 200 cm	200 x 200 cm	214	9	18 kg	Matt white	7413 000 001	Matt white/SE	7413 000 201
250 x 250 cm	250 x 250 cm	264	10.5	28 kg	Matt white	7413 000 008	Matt white/SE	7413 000 208
300 x 300 cm	300 x 300 cm	314	10.5	33 kg	Matt white	7413 000 003	Matt white/SE	7413 000 203
<b>Format 4:3</b>								
135 x 180 cm	129 x 172 cm	194	9	16 kg	Matt white	7413 000 004	Matt white/SE	7413 000 204
150 x 200 cm	144 x 192 cm	214	9	18 kg	Matt white	7413 000 005	Matt white/SE	7413 000 205
180 x 240 cm	174 x 232 cm	254	9	27 kg	Matt white	7413 000 006	Matt white/SE	7413 000 206
225 x 300 cm	219 x 292 cm	314	10.5	33 kg	Matt white	7413 000 007	Matt white/SE	7413 000 207
<b>Format 16:10</b>								
125 x 200 cm	120 x 192 cm	214	9	18 kg	Matt white	7413 000 010	Matt white/SE	7413 000 210
150 x 240 cm	145 x 232 cm	254	9	27 kg	Matt white	7413 000 011	Matt white/SE	7413 000 211
188 x 300 cm	183 x 292 cm	314	10.5	33 kg	Matt white	7413 000 012	Matt white/SE	7413 000 212

\*Screens with fabric matt white/SE without black rim, i.e. screen size = overall dimensions

## Casing for Cineroll Electric

- Steel casing
- Colour RAL 9003 (white)
- Mounting of the casing with four brackets on the ceiling (accessory 5941 000 001)
- European plug for easy mains connection
- Mounting of the screen with 2 bolts
- Easy maintenance
- Pre-installation possible when mounting the false ceiling

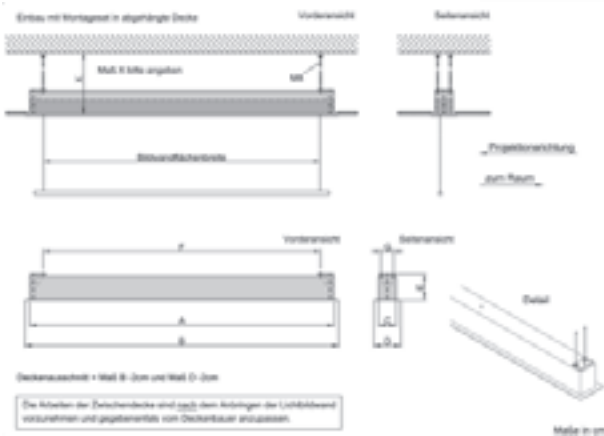

Casing	Width	Dimensions in cm (see illustration)					Ref.N o.	
		A	B	C	D	E		F
	180c m	194	199	9.5	14.5	13.5	183.5	7413 000 040
	200c m	214	219	9.5	14.5	13.5	203.5	7413 000 041
	240c m	254	259	9.5	14.5	13.5	243.5	7413 000 042
	250c m	264	269	11.5	16.5	15.5	253.5	7413 000 044
	300c m	314	319	11.5	16.5	15.5	303.5	7413 000 043

## Installation frame (L profile) for Cineroll Electric

Frame for inserting the cutout of the false ceiling, which covers the casing of the screen

- The size of the profile is 2.5 cm x 2.5 cm; the colour is RAL 9003 white textured point
- Removable caps on the two ends of the screen for easy maintenance
- Modular system, double screws for separating the casing of the screen from the installation frame
- No expert needed for maintenance

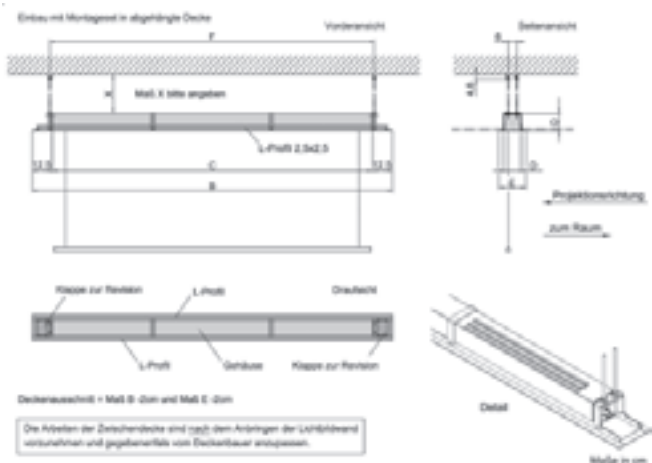

Installation frame / I profile	Width	Dimensions in cm (see illustration)				Ref.N o.	
		B	C	D	E		F
	180c m	219	194	9	13.5	195.5	7413 000 031
	200c m	239	214	9	13.5	215.5	7413 000 032
	240c m	279	254	9	13.5	255.5	7413 000 033
	250c m	289	264	10.5	15.5	265.5	7413 000 034
	300c m	339	314	10.5	15.5	315.5	7413 000 035

## Elpro electrol

### Professional electrical screen



- Wide range of optional plug & play accessories, for installation without electrician
- Easy installation on wall and ceiling
- Perfectly flat projection screen
- 16:9 format available at same price
- Colour of casing RAL 9016 (white)
- Bottom bar with triangle profile is completely integrated in the casing when screen is rolled up
- Custom-made versions available on demand
- Also available in sizes up to 5 m width as model Elpro large electrol

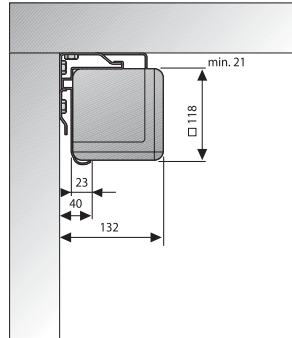
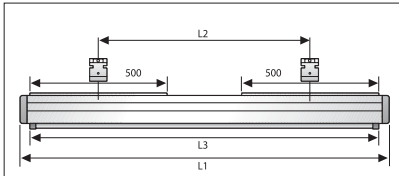

Overall dimensions	Screen size	Dimensions in mm (see illustration)			Weight	Screen fabrics	Ref. No.
		L1	L2	L3			
<b>Format 1:1</b>							
180 x 180 cm	173 x 173 cm	1915	929 - 1729	1820	19 kg	Matt white	5927 000 000
200 x 200 cm	195 x 195 cm	2135	1149 - 1949	2040	23 kg	Matt white	5928 000 000
240 x 240 cm	230 x 230 cm	2535	1549 - 2349	2440	29 kg	Matt white	5973 000 000
300 x 300 cm	290 x 290 cm	3135	2149 - 2949	3040	37 kg	Matt white	5931 000 000
<b>Format 4:3</b>							
138 x 180 cm	126 x 168 cm	1915	929 - 1729	1820	19 kg	Matt white	5980 000 000
153 x 200 cm	143 x 190 cm	2135	1149 - 1949	2040	21 kg	Matt white	5939 000 000
183 x 240 cm	173 x 230 cm	2535	1549 - 2349	2440	26 kg	Matt white	5972 000 000
228 x 300 cm	218 x 290 cm	3135	2149 - 2949	3040	33 kg	Matt white	5940 000 000
<b>Format 16:10</b>							
129 x 200 cm	119 x 190 cm	2135	1149 - 1949	2040	20 kg	Matt white	5925 000 000
154 x 240 cm	144 x 230 cm	2535	1549 - 2349	2440	25 kg	Matt white	5925 000 002
191 x 300 cm	181 x 290 cm	3135	2149 - 2949	3040	30 kg	Matt white	5925 000 004

## Installation frame for Elpro (RF) electrol

- L profile for inserting the false ceiling, ca. 2.5 cm wide, 5 cm high
- Colour RAL 9016 (white)
- Easy installation, no changes of the casing required
- The L profile partly covers the upper black rim of 4:3 format screens



Screen width	Cutout of ceiling	Ref. No.
180 cm	40 x 1865 mm	5940 000 031
200 cm	40 x 2085 mm	5940 000 032
240 cm	40 x 2485 mm	5940 000 033
300 cm	40 x 3085 mm	5940 000 035

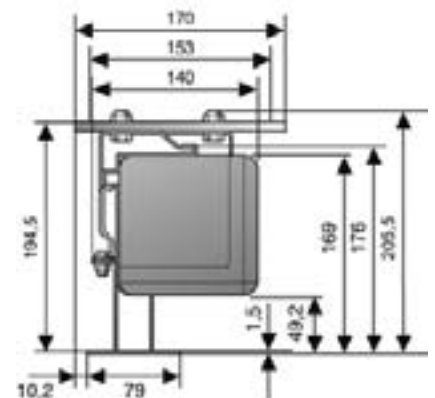

## Cineflex Electric IR

### Well-designed electrical screen

- High-quality aluminium casing, silver
- Plug connection for plug & play: power supply via Schuko plug, cable outlet on the left
- IR remote control with external receiver included in package
- Supplied with brackets for direct mounting on wall or ceiling
- Vario Mounting System (VMS), similar to "Easy Install"



Overall dimensions	Screens size	Dimensions in cm (see illustration)		Weight	Screenf abrics	Ref.No .
		F	G			
<b>Format: 1</b>						
180 x 180 cm	180 x 180 cm	201	185	10 kg	Matt white	7434 000 007
200 x 200 cm	200 x 200 cm	221	205	12 kg	Matt white	7434 000 008
240 x 240 cm	240 x 240 cm	261	245	14 kg	Matt white	7434 000 009
<b>Format4 :3</b>						
137 x 180 cm	129 x 172 cm	201	185	10 kg	Matt white	7434 000 000
152 x 200 cm	144 x 192 cm	221	205	12 kg	Matt white	7434 000 001
182 x 240 cm	174 x 232 cm	261	245	14 kg	Matt white	7434 000 002
<b>Format16:9</b>						
189 x 200 cm	108 x 192 cm	221	205	12 kg	Matt white	7434 000 004
189 x 240 cm	131 x 232 cm	261	245	14 kg	Matt white	7434 000 005

## Compact electrol

### Compact economy screen

- Easy wall and ceiling mounting through integrated mounting kit
- Colour of casing RAL 9016 (white)
- 3 m connection cable and on-wall switch
- Low-noise motor
- Custom-made version available on demand

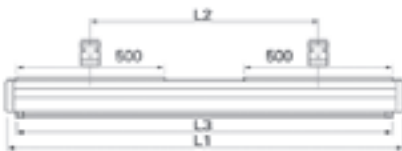

Overall dimensions	Screens size	Dimensions in mm (see illustration)			Weight	Screenf abrics	Ref.No .
		L1	L2	L3			
<b>Format: 1</b>							
180 x 180 cm	173 x 173 cm	1914	914 - 1754	1820	12 kg	Matt white	7400 000 001
200 x 200 cm	195 x 195 cm	2134	1134 - 1974	2040	14 kg	Matt white	7400 000 002
240 x 240 cm	235 x 235 cm	2534	1534 - 2374	2440	18 kg	Matt white	7400 000 003
<b>Format4 :3</b>							
138 x 180 cm	126 x 168 cm	1914	914 - 1754	1820	12 kg	Matt white	7400 000 005
153 x 200 cm	143 x 190 cm	2134	1134 - 1974	2040	14 kg	Matt white	7400 000 006
183 x 240 cm	173 x 230 cm	2534	1534 - 2374	2440	18 kg	Matt white	7400 000 007
<b>Format16: 10</b>							
129 x 200 cm	119 x 190 cm	2134	1134 - 1974	2040	14 kg	Matt white	7400 000 009
154 x 240 cm	144 x 230 cm	2534	1534 - 2374	2440	18 kg	Matt white	7400 000 011

## Reality

### Low-budget electrical screen

- Eight-sided metal casing
- Black frame
- Low-noise motor
- Supplied with IR remote control

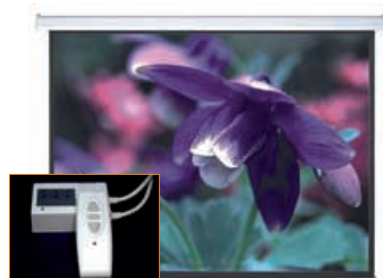

Overall dimensions	Screens size	Screenf abrics	Ref.No .
<b>Format: 1</b>			
208 x 232 cm	200 x 200 cm	Matt white	6929 000 000
248 x 272 cm	240 x 240 cm	Matt white	6929 000 001
308 x 332 cm	300 x 300 cm	Matt white	6929 000 002



## Hapro manual Screen with manual crank



- Perfectly flat hanging screen
- High-quality crank mechanism
- Custom-made versions available on demand
- Easy wall or ceiling mounting
- Supplied with detachable crank
- Colour of casing RAL 9016, (white)

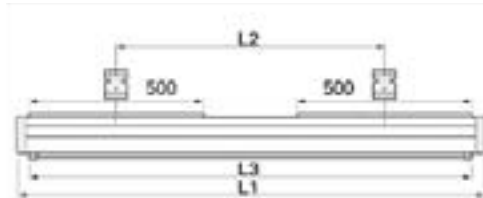

Overall dimensions	Screen size	Dimensions in mm (see illustration)			Weight	Screen fabrics	Ref. No.
		L1	L2	L3			
<b>Format 1:1</b>							
180 x 180 cm	173 x 173 cm	1915	929 - 1729	1820	18 kg	Matt white	5947 000 000
200 x 200 cm	195 x 195 cm	2135	1149 - 1949	2040	22 kg	Matt white	5945 000 000
240 x 240 cm	230 x 230 cm	2535	1549 - 2349	2440	28 kg	Matt white	5897 000 000
300 x 300 cm	290 x 290 cm	3135	2149 - 2949	3040	36 kg	Matt white	5898 000 000
<b>Format 4:3</b>							
138 x 180 cm	126 x 168 cm	1915	929 - 1729	1820	18 kg	Matt white	7412 000 000
153 x 200 cm	143 x 190 cm	2135	1149 - 1949	2040	20 kg	Matt white	7412 000 002
183 x 240 cm	173 x 230 cm	2535	1549 - 2349	2440	25 kg	Matt white	7412 000 004
228 x 300 cm	218 x 290 cm	3135	2149 - 2949	3040	31 kg	Matt white	7412 000 008

## Cinelux Rollo



- High-quality aluminium casing, silver
- With slow-down mechanism for exact rolling up of the screen
- Vario Mounting System (VMS) for easy wall or ceiling mounting, similar to "Easy Install"
- The bottom bar is integrated in the casing when screen is rolled up

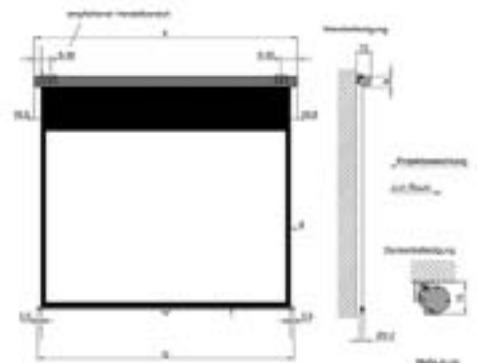

Overall dimensions	Screen size	Dimensions in mm (see illustration)		Weight	Matt white
		F	Fixing points		
<b>Format 1:1</b>					
180 x 180 cm	180 x 180 cm	1900	1300 - 1800	8.5 kg	5954 000 001
200 x 200 cm	200 x 200 cm	2100	1500 - 2000	9.5 kg	5954 000 002
<b>Format 4:3</b>					
135 x 180 cm	129 x 172 cm	1900	1300 - 1800	8.5 kg	5954 000 003
150 x 200 cm	144 x 192 cm	2100	1500 - 2000	9.5 kg	5954 000 004
180 x 240 cm	174 x 232 cm	2500	1900 - 2400	12.5 kg	5954 000 005

## ProScreen

High-quality screen with spring mechanism



- Big rotary shaft for flat projection screen and powerful spring mechanism, easy to roll up
- Easy wall or ceiling mounting through integrated mounting kit
- CSR: Controlled Screen Return, for slowing down the rolling up of the screen

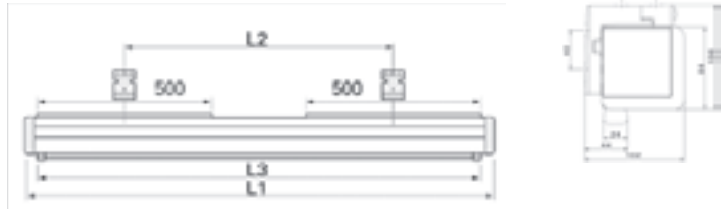

Overall dimensions	Screens size	Dimensions in mm (see illustration)			Weight	Mattw hite	Mattw hite Model CSR
		L1	L2	L3			
<b>Format1: 1</b>							
180 x 180 cm	173 x 173 cm	1914	914 - 1754	1820	12 kg	5950 000 000	5950 000 005
200 x 200 cm	195 x 195 cm	2134	1134 - 1974	2040	14 kg	5951 000 000	5951 000 005
240 x 240 cm	235 x 235 cm	2534	1534 - 2374	2440	17 kg	5952 000 000	5952 000 005
<b>Format4 :3</b>							
138 x 180 cm	126 x 168 cm	1914	914 - 1754	1820	11 kg	5950 000 001	5953 000 005
153 x 200 cm	143 x 190 cm	2134	1134 - 1974	2040	13 kg	5955 000 000	5955 000 005
183 x 240 cm	173 x 230 cm	2534	1534 - 2374	2440	16 kg	5956 000 000	5956 000 005
213 x 280 cm	203 x 270 cm	2934	1934 - 2774	2840	19 kg	5962 000 000	
<b>Format16: 10</b>							
115 x 180 cm	105 x 168 cm	1914	914 - 1754	1820	11 kg	5950 000 002	5958 000 000
129 x 200 cm	119 x 190 cm	2134	1134 - 1974	2040	12 kg	5955 000 001	5958 000 001
154 x 240 cm	144 x 230 cm	2534	1534 - 2374	2440	16 kg	5956 000 001	5958 000 003
179 x 280 cm	169 x 270 cm	2934	1934 - 2774	2840	18 kg	5962 000 002	

## Slim Screen (XL)

Basic model with spring mechanism

- Spring mechanism for hassle-free rolling up and lowering of the screen
- Easy wall or ceiling mounting through integrated mounting kit

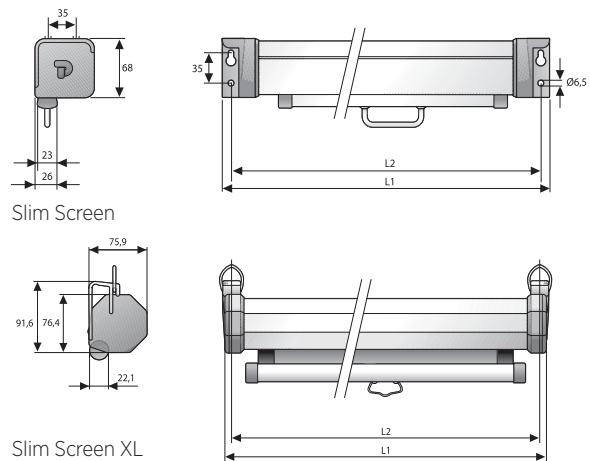

Overall dimensions	Screens size	Dimensions in mm (see illustration)		Weight	Mattw hite/S	Datalux/S
		L1	L2			
<b>Format1: 1</b>						
160 x 160 cm	151 x 151 cm	1718	1696	7 kg	5992 000 000	5994 000 000
180 x 180 cm	173 x 173 cm	1918	1896	8 kg	5993 000 000	5995 000 000
200 x 200 cm	195 x 195 cm	2138	2116	9 kg	5995 000 001	5995 000 002
244 x 244 cm (XL)	234 x 234 cm	2524	2505	11 kg	5995 000 003	
<b>Format4 :3</b>						
123 x 160 cm	110 x 146 cm	1718	1696	6 kg	5996 000 000	5998 000 000
138 x 180 cm	126 x 168 cm	1918	1896	7 kg	5997 000 000	5999 000 000
153 x 200 cm	143 x 190 cm	2138	2116	8 kg	5999 000 001	5999 000 002
185 x 244 cm (XL)	175 x 234 cm	2524	2505	10 kg	5999 000 003	

## Accessories

Illustration	Model	Specification	Length	Ref. No.
	<b>Bracket for ceiling mounting</b>	For Tensioned Descender, Elpro electrol, Hapro manual	100 cm, can be shortened	5941 000 000
		For Cineroll Electric	100 cm, can be shortened	5941 000 001
		For Compact electrol, Pro Screen, Slim Screen, Pro Cinema	100 cm, can be shortened	7411 000 000
		For Elpro large electrol	100 cm, can be shortened	5941 000 001
		For Jumbo	100 cm, can be shortened	5941 000 003
	<b>Keystone bracket</b>	For Elpro electrol, Compact electrol, Hapro manual, Pro Screen	75 cm 30 cm	5942 000 000 5942 000 004
		For Elpro large electrol	40 cm	5942 000 001
		For Slim Screen (except XL version)	57 cm	5942 000 002
		For Cineroll Electric	40 cm	5942 000 003
	<b>Bracket for casing</b>	For mounting Easy Install screens in false ceilings		5943 000 001
	<b>Pull rod</b>	For all manually operated screens	125 cm	5959 000 000
	<b>Radio remote control</b>	With wireless switch and mobile sender, up to 30 m distance; for all electrical screens		5944 000 000
	<b>Key switch</b>	For all electrical screens		5944 000 001

## Home Screen



- Flat, 8 cm wide black aluminium frame, inner edge bevelled to avoid shadows
- Easy mounting of frame and screen
- Easy fixing of projection screen through tautening mechanism

Overall dimensions	Screen size	Weight	Matt white
<b>Format 4:3</b>			
136 x 176 cm	120 x 160 cm	9 kg	7408 000 000
151 x 196 cm	135 x 180 cm	10 kg	7408 000 020
166 x 216 cm	150 x 200 cm	11 kg	7408 000 001
196 x 256 cm	180 x 240 cm	12 kg	7408 000 002
241 x 316 cm	225 x 300 cm	16 kg	7408 000 003
<b>Format 16:9</b>			
118 x 196 cm	102 x 180 cm	9 kg	7408 000 004
128 x 216 cm	135 x 180 cm	10 kg	7408 000 005
151 x 256 cm	135 x 240 cm	11 kg	7408 000 007

## Cinestativ Mobil



- Mobile and yet stable through four lockable castors
- For easy transport; ideal for schools, hotels and restaurants
- Diameter of base 63 cm
- High-quality aluminium casing, silver, sturdy construction
- Integrated Keystone bracket

Overall dimensions	Screens size	Overall height	Weight	Screen fabrics	Ref.No .
<b>Format 1:1</b>					
150 x 150 cm	146 x 146 cm	max. 275 cm	14 kg	Matt white	5921 000 002
180 x 180 cm	176 x 176 cm	max. 335 cm	15 kg	Matt white	5922 000 002
200 x 200 cm	196 x 196 cm	max. 355 cm	17 kg	Matt white	5922 000 003



### Pro View

- The attractive economy tripod screen
- Easy to carry for universal use
- Easy to install
- Sturdy stand, tube bars, with integrated Keystone bracket

### Standard

- The tripod screen for the small budget
- Black metal case and tripod
- Mechanism for flat projection surface
- Low weight and compact design

Overall dimensions	Screens size	Screen fabrics	Ref.N o.
<b>Pro View Format 1:1</b>			
125 x 125 cm	120 x 120 cm	Matt white/S	5920 000 000
160 x 160 cm	151 x 151 cm	Matt white/S	5921 000 000
180 x 180 cm	173 x 173 cm	Matt white/S	5922 000 000
<b>Standard Format 1:1</b>			
ca. 130 x 130 cm	125 x 125 cm	Matt white	6927 000 000
ca. 162 x 162 cm	155 x 155 cm	Matt white	6927 000 001
ca. 188 x 188 cm	180 x 180 cm	Matt white	6927 000 002

## Picture King



- Very sturdy square profiles with Keystone bracket
- Foot switch for easy folding of tripod
- Handle with integrated stop for convenient transport and easy height adjustment

Overall dimensions	Screens size	Overall height	Weight	Matt white
<b>Format 1:1</b>				
152 x 152 cm	146 x 146 cm	max. 282 cm	14 kg	5915 000 001
178 x 178 cm	172 x 172 cm	max. 325 cm	16 kg	5915 000 003
213 x 213 cm	207 x 207 cm	max. 325 cm	18 kg	5915 000 005
244 x 244 cm	238 x 238 cm	max. 325 cm	20 kg	5915 000 007
<b>Format 4:3</b>				
135 x 178 cm	127 x 170 cm	max. 300 cm	15 kg	5915 000 009
162 x 213 cm	152 x 203 cm	max. 325 cm	17 kg	5915 000 011
185 x 244 cm	175 x 234 cm	max. 325 cm	19 kg	5915 000 000



Protective covers for Pro View / Picture King	
Size 127 / 152 cm	7417 000 001
Size 178 cm	7417 000 002
Size 213 cm	7417 000 003
Size 244 cm	7417 000 004



## Fast Fold

Mobile screen for large-screen projection



- Ideal for big events
- Solid light-weight aluminium frame
- Stand and frame collapsible for transport
- Easy to install, no tools required
- Fixing of projection screen with snap fasteners
- Supplied with sturdy case for transport and storage

Overall dimensions	Screen size	Height: min. - max.	Weight	Matt white	Datex/R
<b>Format 4:3</b>					
160 x 213 cm	150 x 203 cm	165 cm - 295 cm	21 kg	5909 000 000	5909 000 001
183 x 244 cm	173 x 234 cm	188 cm - 316 cm	23 kg	5905 000 000	5905 000 001
228 x 305 cm	218 x 295 cm	233 cm - 363 cm	28 kg	5906 000 000	5906 000 001
274 x 366 cm	264 x 356 cm	279 cm - 409 cm	31 kg	5907 000 000	5907 000 001
320 x 427 cm	310 x 417 cm	325 cm - 500 cm	36 kg	5908 000 000	5908 000 001

## Cinelux Compact Mono

Inexpensive and mobile



- V-shaped aluminium casing, black
- Easy and quick to set up
- Integrated deposit tray for pointer
- Stepless height adjustment

Overall dimensions	Screen size	Overall height	Black bottom rim	Weight	Matt white/WD
<b>Format 4:3</b>					
120 x 160 cm	117 x 156 cm	max. 194 cm	68 cm	14 kg	7427 000 000
135 x 180 cm	132 x 176 cm	max. 214 cm	73 cm	15 kg	7427 000 001
150 x 200 cm	147 x 196 cm	max. 214 cm	58 cm	16 kg	7427 000 002

## Cinelux Mobil 2

Most flexible and mobile



- Ready to use in no time due to concertina elements at the rear side
- Stepless height adjustment
- Integrated transport handles and four castors for easy transport

Overall dimensions	Screen size	Overall height	Black bottom rim	Weight	Matt white/WF
<b>Format 1:1</b>					
200 x 200 cm	196 x 196 cm	max. 217 cm	0 cm	17 kg	7427 000 013
<b>Format 4:3</b>					
135 x 180 cm	132 x 176 cm	max. 197 cm	59 cm	16 kg	7427 000 011
150 x 200 cm	147 x 196 cm	max. 217 cm	64 cm	17 kg	7427 000 012
180 x 240 cm	177 x 236 cm	max. 217 cm	34 cm	18 kg	7427 000 014

## Lite Screen

Light and mobile



- Sturdy aluminium casing with carrying grip
- Sturdy construction, two extendable feet
- Easy height adjustment through concertina construction with pneumatic spring
- Ready for projection in no time

Overall dimensions	Screen size	Overall height	Black bottom rim	Weight	Datalux/F
<b>Format 4:3</b>					
98 x 128 cm	90 x 120 cm	max. 195 cm	98 cm	8 kg	5976 000 000
128 x 168 cm	120 x 160 cm	max. 208 cm	80 cm	9 kg	5977 000 000
160 x 211 cm	152 x 203 cm	max. 250 cm	92 cm	11 kg	5977 000 001

## Fast and easy ordering: The new Kindermann webshop for dealers

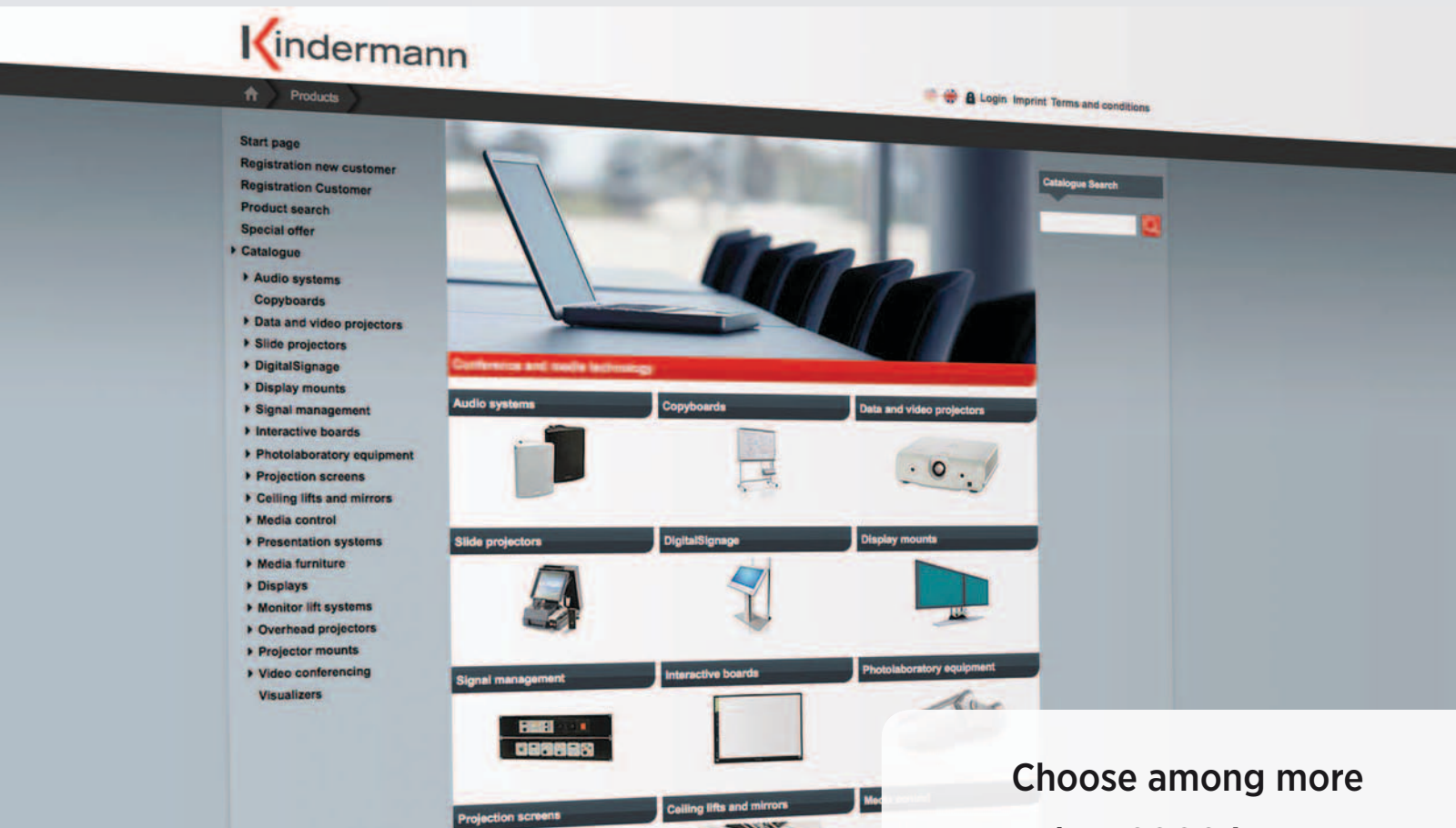

Choose among more  
than 2000 items!

### Your advantages

- Order online
- Check availability
- Check order status
- See current offers
- Find product information

Visit us at [www.shop.kindermann.de](http://www.shop.kindermann.de)

